

Installation Guide

Gas Detection Unit (GDU)

GDA, GDC, GDHC, GDHF, GDH



ENGLISH

148R9631

148R9631

Technician use only!

This unit must be installed by a suitably qualified technician who will install this unit in accordance with these instructions and the standards set down in their particular industry/country.

Suitably qualified operators of the unit should be aware of the regulations and standards set down by their industry/country for the operation of this unit.

These notes are only intended as a guide and the manufacturer bears no responsibility for the installation or operation of this unit.

Failure to install and operate the unit in accordance with these instructions and with industry guidelines may cause serious injury including death and the manufacturer will not be held responsible in this regard.

It is the installer's responsibility to adequately ensure that the equipment is installed correctly and set up accordingly based on the environment and the application in which the products are being used.

Please observe that a Danfoss GDU works as a safety device securing a reaction to a detected high gas concentration. If a leakage occur, the GDU will provide alarm functions, but it will not solve or take care of the leakage root cause itself.

Annual Test

To comply with the requirements of EN378 and the F GAS regulation sensors must be tested annually. Danfoss GDU's are provided with a test button that should be activated once a year for testing of the alarm reactions.

Additional the sensors must be tested for functionality by either Bump test or Calibration. Local regulations should always be followed

After exposure to a substantial gas leak, sensor should be checked and replaced if necessary.

Check local regulations on calibration or testing requirements.

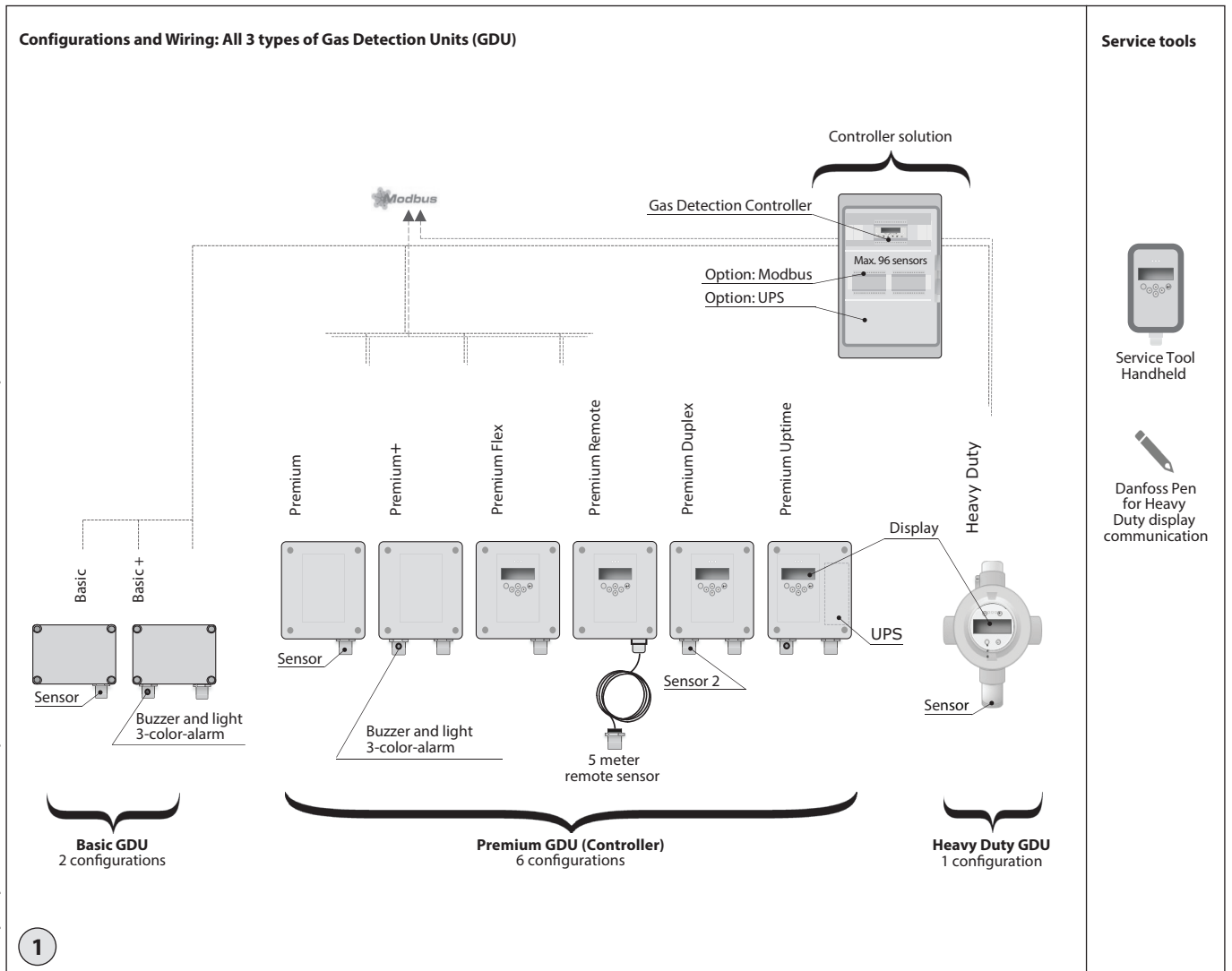

Імпортер: ТОВ з іі "Данфосс ТОВ" 04080, Київ 80, п/с 168, Україна

Info for UK customers only : Danfoss Ltd., 22 Wycombe End, HP9 1NB, GB

Danfoss Basic GDU

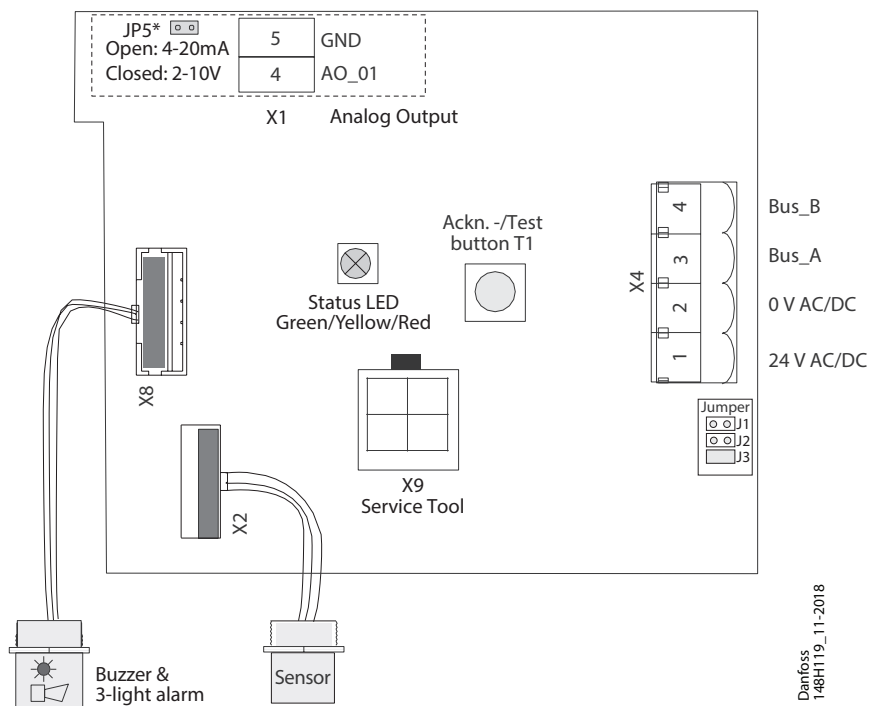

Danfoss 148H119_11-2018

Status LED:

GREEN is power on.

YELLOW is an indicator of Error.

- when the sensor head is disconnected or not the expected type
- AO is activated but nothing connected
- flashing when sensor is in special mode (e.g. when changing parameters)

RED on alarm, similar to the Buzzer & light alarm.

Ackn. -/Test button:

TEST - The button must be pressed for 20 sec.

- Alarm 1 and Alarm2 is simulated, stop on release

ACKN. - Pressed while Alarm2, the audible warning switches off and goes back on after 5 min. when the alarm situation is still active.

- * JP5 open → AO 4 – 20 mA (Default)
- JP5 closed → AO 2 – 10 Volt

NOTE:

A resistor comes installed on the analog output connections – if analog output is used, remove the resistor.

2

Danfoss Premium GDU

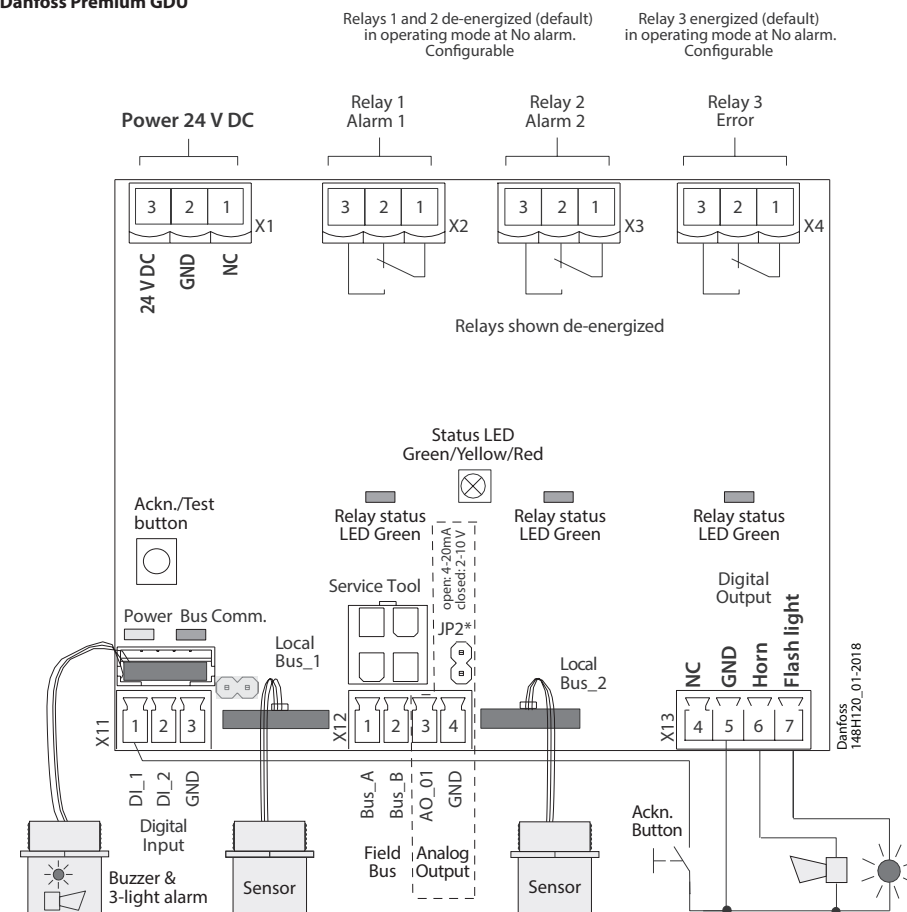

Danfoss 148H120_01-2018

Status LED:

GREEN is power on.

YELLOW is an indicator of Error.

- when the sensor head is disconnected or not the expected type
- AO is activated but nothing connected

RED on alarm, similar to the Buzzer & light alarm.

Ackn. -/Test button:

TEST - The button must be pressed for 20 sec.

- Alarm 1 and Alarm2 is simulated, stop on release

ACKN. - Pressed while Alarm2, the audible warning switches off and goes back on after 5 min. when the alarm situation is still active.

- * JP2 open → AO 4 – 20 mA (Default)
- JP2 closed → AO 2 – 10 Volt

NOTE:

A resistor comes installed on the analog output connections – if analog output is used, remove the resistor.

3

Danfoss Premium Uptime GDU

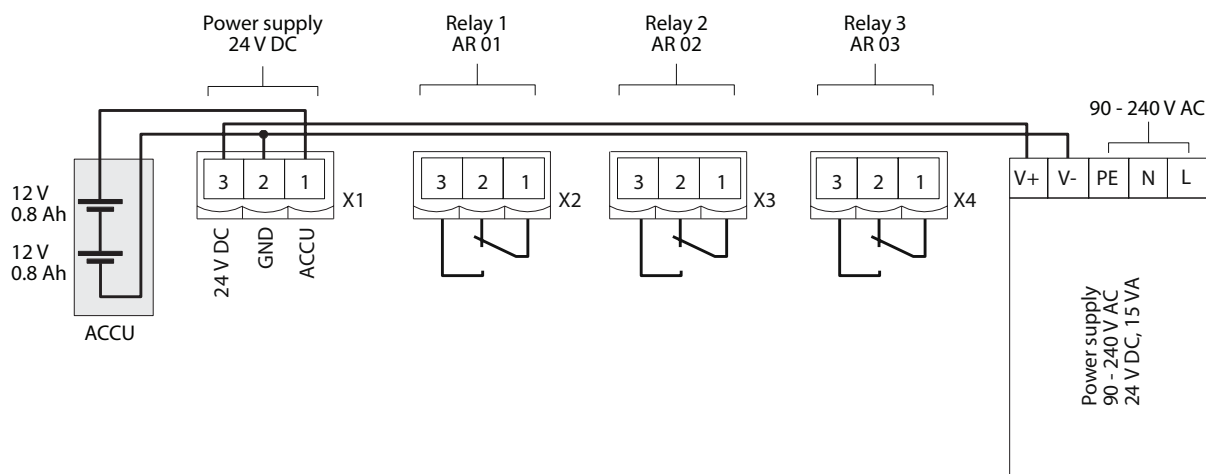

Danfoss
148H147_02.2018

4

Danfoss Heavy Duty GDU (ATEX, IECEx approved)

Sensor PX2

1	+24 V DC
2	+24 V DC
3	GND
4	BUS_A
5	BUS_B
6	4 - 20 mA output
7	Fault relays energized in operating mode at No alarm - Default
8	
9	Alarm relays de-energized in operating mode at No alarm - Default (Configurable)
10	
11	

Danfoss
148H122_11-2018

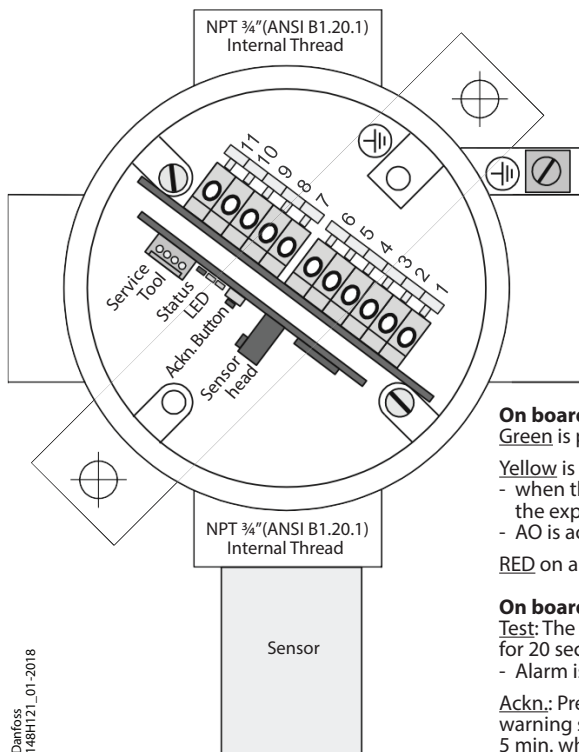

Danfoss
148H121_01-2018

On board LED is similar to the display LED:

- Green is power on
- Yellow is an indicator of Error
 - when the sensor head is disconnected or not the expected type
 - AO is activated but nothing connected
- RED on alarm

On board Ackn. -/Test button:

- Test:** The button must be pressed for 20 sec.
 - Alarm is simulated, stop on release
- Ackn.:** Pressed while Alarm2, the audible warning switches off and goes back on after 5 min. when the alarm situation is still active (also possible over ESC button (use the magnetic Pen).

5

Location of Sensors

Gas type	Relative density (Air = 1)	Recommended sensor location
R717 Ammonia	<1	Ceiling
R744 CO ₂	>1	Floor
R134a	>1	Floor
R123	>1	Floor
R404A	>1	Floor
R507	>1	Floor
R290 Propane	>1	Floor

6

Gas Detection Controller: Fieldbus wiring - max 96 sensors in total i.e. up to 96 GDU (Basic, Premium and/or Heavy Duty)

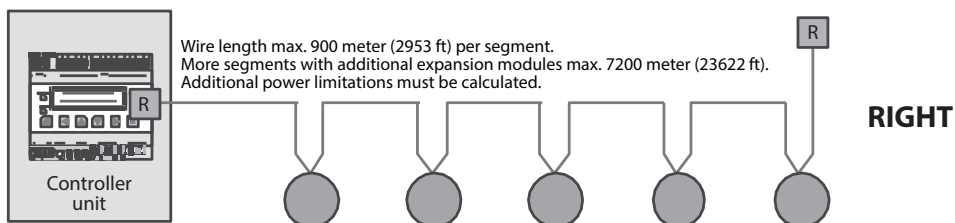

R = Terminating resistor 560 Ohm
 ● = GDU (Basic, Premium and/or Heavy Duty)

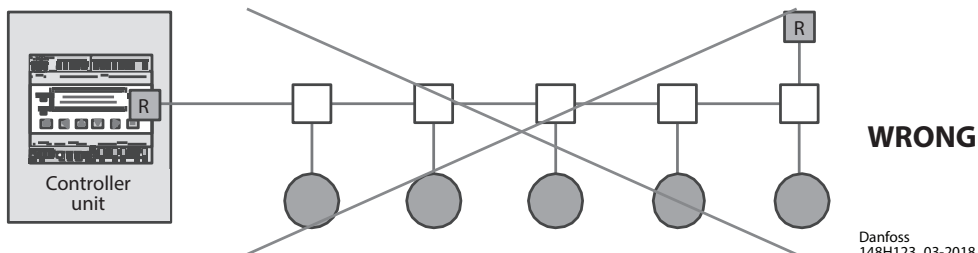

Danfoss
148H123_03-2018

7

Check of loop completion. Example: 5 x Basic in return loop

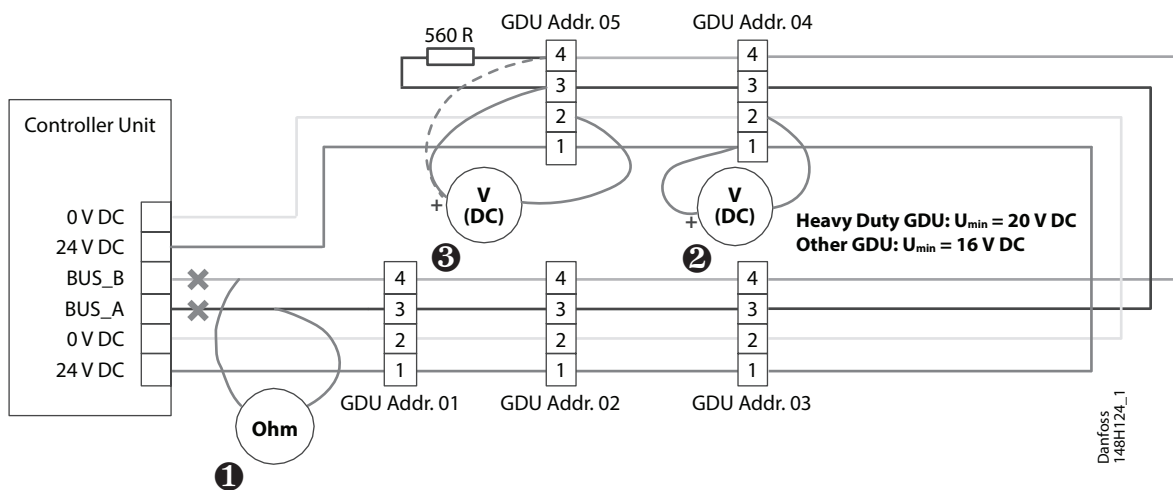

Danfoss
148H124_1

- ① Check of loop resistance: See section: Controller unit multiple GDU commissioning 2. **NOTE:** Remember to disconnect the wire from the board during measuring.
- ② Check of power polarity: See section: Controller unit multiple GDU commissioning 3.
- ③ Check of BUS polarity: See section: Controller unit multiple GDU commissioning 3.

Individual Addresses for the GDU's are given at commissioning, see Controller Unit multiple GDU's commissioning, according to a predetermined "BUS address plan"

8

Attachment of suspension ears (Basic and Premium)

Danfoss
148H125_01-2018

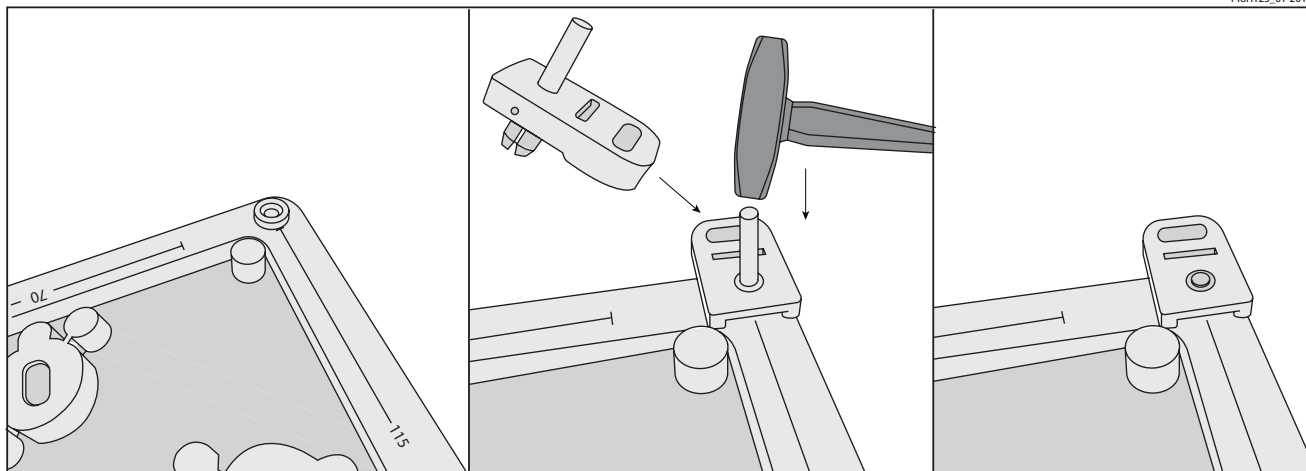

9

Cable Gland opening

Danfoss
148H126_01-2018

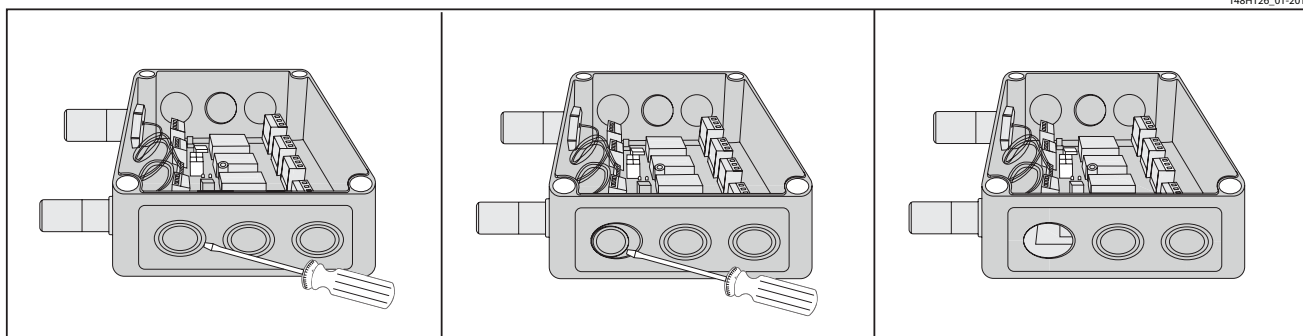

Hole punching for Cable gland:

1. Select the location for the safest cable entry.
2. Use a sharp screwdriver and a small hammer.
3. Place the screwdriver and hammer with precision while moving the screwdriver within a small area until the plastic is penetrated.

Continue precision punching with small movements until the round piece can be pulled out by your fingers.

Remove potential burrs and secure flat surfaces. Install the Cable gland according to the enclosed guide.

10

Ambient conditions :

Please observe the ambient conditions specified for each specific GDU, as stated on the product. Do not install the units outside the given temperature and humidity range.

General GDU Mounting / Electrical wiring

- All GDU's are for wall mounting
- Supporting ears are installed like shown in fig. 9
- Cable entry is recommended on box side. See fig. 10
- Sensor position downwards
- Observe possible constructors instruction
- Leave the red protection cap (seal) on the sensor head until commissioning

When choosing the mounting site please pay attention to the following:

- The mounting height depends on the relative density of the gas type to be monitored, see fig 6.
- Choose mounting location of the sensor according to the local regulations
- Consider ventilation conditions. Do not mount the sensor close to airflow (air passages, ducts etc.)
- Mount the sensor at a location with minimum vibration and minimum temperature variation (avoid direct sunlight)
- Avoid locations where water, oil etc. may influence proper operation and where mechanical damage might be possible
- Provide adequate space around the sensor for maintenance and calibration work.

Wiring

The technical requirements and regulations for wiring, electrical security, as well as project specific and environmental conditions etc. must be observed when mounting.

We recommend the following cable types¹

- Power supply for controller 230V at least NYM-J 3 x 1.5 mm²
- Alarm message 230 V (also possible together with power supply) NYM-J X x 1.5 mm²
- Signal message, bus connection to Controller Unit, warning devices 24 V J-Y(St)Y 2x2 x 0.8
- Possibly connected external analog transmitters J-Y(St)Y 2x2 x 0.8
- Cable for Heavy Duty: 7 - 12 mm diameter round cable

¹The recommendation does not consider local conditions such as fire protection etc.

The alarm signals are available as potential-free change-over contacts. If required the voltage supply is available at the power terminals.

The exact position of the terminals for the sensors and alarm relays is shown in the connection diagrams (see figures 3 and 4).

Basic GDU

The Basic GDU is designed for the connection of 1 sensor via local bus.

The GDU provides the power supply of the sensor and makes the measured data available for digital communication. Communication with the Controller Unit takes place via the RS 485 fieldbus interface with Controller Unit protocol. Other communication protocols for direct connection to superordinate BMS are available as well as Analog Output 4-20 mA.

The sensor is connected to the local bus via a plug connection enabling simple sensor exchange instead of an on-site calibration. The internal X-Change routine recognizes the exchanging process and the exchanged sensor and starts the measurement mode automatically. The internal X-change routine examines the sensor for actual type of gas and actual measuring range. If data does not match the existing configuration, the build in status LED indicates an error. If everything is OK the LED will light up green.

For convenient commissioning, the GDU is pre-configured and parameterized with factory-set defaults. As an alternative, the on-site calibration via the Controller Unit Service Tool can be performed with the integrated, userfriendly calibration routine.

For Basic units with Buzzer & Light, alarms will be given according to following table:

Digital outputs

Action	Reaction Horn	Reaction LED
Gas signal < alarm threshold 1	OFF	GREEN
Gas signal > alarm threshold 1	OFF	RED Slow blinking
Gas signal > alarm threshold 2	ON	RED Fast blinking
Gas signal ≥ alarm threshold 2, but ackn. button pressed	OFF after delay ON	RED Fast blinking
Gas signal < (alarm threshold 2 - hysteresis) but ≥ alarm threshold 1	OFF	RED Slow blinking
Gas signal < (alarm threshold 1 - hysteresis) but not acknowledged	OFF	RED Very fast blinking
No alarm, no fault	OFF	GREEN
No fault, but maintenance due	OFF	GREEN Slow blinking
Communication error	OFF	YELLOW

Alarm thresholds can have the same value, therefore the relays and/or Buzzer and LED can be triggered simultaneously.

Premium GDU (Controller)

The Premium GDU is designed for the connection of max. two sensors via local bus. The controller monitors the measured values and activates the alarm relays if the set alarm thresholds for pre-alarm and main alert are exceeded. In addition, the values are provided for direct connection to the monitoring system (Controller Unit) via an RS-485 interface. Other communication protocols for direct connection to superordinate BMS are available as well as Analog Output 4-20 mA.

The SIL 2 compliant self-monitoring function in the Premium GDU and in the connected sensor activates the error message in case of an internal error as well as in case of an error in the local bus communication.

The sensor is connected to the local bus via a plug connection enabling simple sensor exchange instead of an on-site calibration. The internal X-Change routine recognizes the exchanging process and the exchanged sensor and starts the measurement mode automatically.

The internal X-change routine examines the sensor for actual type of gas and actual measuring range and if data does not match the existing configuration, the build in status LED indicates an error. If everything is OK the LED will light up green.

For convenient commissioning, the GDU is pre-configured and parameterized with factory-set defaults.

As an alternative, the on-site calibration via the Controller Unit Service Tool can be performed with the integrated, userfriendly calibration routine.

Digital outputs with three relays

Action	Reaction	Reaction	Reaction	Reaction	Reaction	Reaction
	Relay 1 (Alarm1)	Relay 2 (Alarm2)	Flashlight X13-7	Horn X13-6	Relay 3 (Fault)	LED
Gas signal < alarm threshold 1	OFF	OFF	OFF	OFF	ON	GREEN
Gas signal > alarm threshold 1	ON	OFF	OFF	OFF	ON	RED Slow blinking
Gas signal > alarm threshold 2	ON	ON	ON	ON	ON	RED Fast blinking
Gas signal ≥ alarm threshold 2, but ackn. button pressed	ON	ON	ON	OFF after delay ON		RED Fast blinking
Gas signal < (alarm threshold 2 - hysteresis) but ≥ alarm threshold 1	ON	OFF	OFF	OFF	ON	RED Slow blinking
Gas signal < (alarm threshold 1 - hysteresis) but not acknowledged	OFF	OFF	OFF	OFF	ON	RED Very fast blinking
No alarm, no fault	OFF	OFF	OFF	OFF	ON	GREEN
No fault, but maintenance due	OFF	OFF	OFF	OFF	ON	GREEN Slow blinking
Communication error	OFF	OFF	OFF	OFF	OFF	YELLOW

Note 1: Status OFF = Relay is configured "Alarm ON = Relay" or the Premium Multi-Sensor-Controller is free from tension.

Note 2: Alarm thresholds can have the same value, therefore the relays and/or the horn and flashlight can be triggered together.

Relay Mode

Definition of the relay operation mode. The terms energized / de-energized come from the terms energized / de-energized to trip principle (open-circuit / closed circuit principle) used for safety circuits. The terms refer to the activation of the relay coil, not to the relay contacts (as they are executed as a changeover contact and available in both principles).

The LEDs attached to the modules show the two states in analogy (LED off -> relay de-energized)

Heavy Duty GDU

Approved according to ATEX and IECEx for zones 1 and 2.
Permitted ambient temperature range: $-40\text{ °C} < T_a < +60\text{ °C}$

Marking:
Ex Symbol and
II 2G Ex db IIC T4 Gb CE 0539

Certification:
BVS 18 ATEX E 052 X
IECEx BVS 18.0044X

The Heavy Duty GDU is designed for the connection of 1 sensor via local bus.

The GDU provides the power supply of the sensor and makes the measured data available for digital communication. Communication with the Controller Unit takes place via the RS 485 fieldbus interface with Controller Unit protocol. Other communication protocols for direct connection to superordinate BMS are available as well as Analog Output 4-20 mA.

The sensor is connected to the local bus via a plug connection enabling simple sensor exchange instead of an on-site calibration. The internal X-Change routine recognizes the exchanging process and the exchanged sensor and starts the measurement mode automatically.

The internal X-change routine examines the sensor for actual type of gas and actual measuring range. If data does not match the existing configuration, the build in status LED indicates an error. If everything is OK the LED will light up green.

For convenient commissioning, the GDU is pre-configured and parameterized with factory-set defaults.

As an alternative, the on-site calibration via the Controller Unit Service Tool can be performed with the integrated, userfriendly calibration routine.



Installation Work

Assembly work must only be carried out under gas-free conditions. The housing must neither be drilled nor be drilled through.

The orientation of the GDU should always be horizontal, with the sensor head pointing downwards.

The mounting is done without opening the housing by using the two holes (D = 8 mm) of the fastening strap with suitable screws.

The Heavy duty GDU must only be opened under gas-free and voltage-free conditions.

The enclosed cable gland has to be checked for admissibility for the requested requirements before installation in position "Entry 3". If the Heavy duty GDU is supplied without cable gland, a special cable gland approved for Ex protection class EX d and for the requirements of the application has to be mounted there.

When inserting the cables you have to strictly follow the instructions enclosed to the cable glands.

No insulating sealing material must be poured into the NPT 3/4" threads of the cable gland and blanking plugs because the potential equalization between housing and cable gland / blind plugs is via the thread.

The cable gland must be tightened firmly with a suitable tool to torque 15 Nm. Only when doing so you can ensure the required tightness.

After completion of work, the GDU must be closed again. The cover has to be completely screwed in and secured with the locking screw against inadvertent loosening.

General Notes

- The terminals of the Heavy duty GDU are located behind the display.
- Only a professional should perform the wiring and the connection of the electrical installation according to the wiring diagram in compliance with the relevant regulations and only when de-energized!
- When connecting cables and conductors, please observe minimum length of 3 m according to EN 60079-14.
- Connect the housing to the equipotential bonding via the external ground terminal.
- All terminals are Ex e type with spring contact and push actuation. The permissible conductor cross section is 0.2 to 2.5 mm² for single wires and multi-wire cables.
- Use cables with a braided shield for compliance with the interference immunity. The shield must be connected to the inside connection of the housing with a maximum length of about 35 mm.
- For the recommended cable types, cross sections and lengths please refer to the table below.
- To comply with the requirements of servicing or operating the device without opening it (EN 60079-29-1 4.2.5) it is possible to calibrate or operate the device remotely via the central bus. For this it is necessary to lead the central bus out to the safe area via a cable.

Further Notes and Restrictions

The maximum operating voltage and the terminal voltage of the relays have to be limited to 30 V by adequate measures.

The maximum switching current of the two relay contacts should be limited to 1 A by appropriate external measures.

Repairs to flameproof joints are not intended and lead to the immediate loss of the type approval for the pressure-resistant casing.

	Cross-section (mm ²)	Max. length for 24 V DC ¹ (m)
With P, freon sensor heads		
Operating voltage with 4-20 mA signal	0.5	250
	1.0	500
Operating voltage with central bus ²	0.5	300
	1.0	700
With SC, EC sensor heads		
Operating voltage with 4-20 mA signal	0.5	400
	1.0	800
Operating voltage with central bus ²	0.5	600
	1.0	900

¹ The max. cable lengths and our recommendation don't consider any local conditions, like fire protection, national regulations etc.

² For the central bus we recommend using the cable JE-LIYCY 2x2x0.8 BD or 4 x2x0.8 BD.

Commissioning

For sensors that can be poisoned by e.g. silicones like all semiconductor and catalytic bead sensors, it is imperative to remove the protective (seal) cap supplied only after all silicones are dry, and then energize the device.

For fast and comfortable commissioning we recommend proceeding as follows. For digital devices with self-monitoring all internal errors are visible via the LED. All other error sources often have their origins in the field, because it is here where most of the causes for problems in the field bus communication appear.

Optical Check

- Right cable type used.
- Correct mounting height according to definition in Mounting.
- Led status

Comparing sensor gas type with GDU default settings

Each sensor ordered is specific and must match the GDU default settings.

The GDU software automatically reads the specification of the connected sensor and compares with the GDU settings.

If other gas sensor types are connected, you have to adjust them with the configuration tool, because otherwise the device will respond with an error message.

This feature increases the user and operating security.

New sensors are always delivered factory-calibrated by Danfoss. This is documented by the calibration label indicating date and calibration gas. A repeated calibration is not necessary during commissioning if the device is still in its original packaging (air-tight protection by the red protective cap) and the calibration doesn't date back more than 12 months.

Functional test (for initial operation and maintenance)

The functional test should be carried out during each service, but at least once a year.

Functional test is done by pressing the test button for more than 20 sec and observing all connected outputs (Buzzer, LED, Relay connected devices) working properly. After deactivation all outputs must automatically return to its initial position

Zero-point test with fresh outdoor air

Zero-point test with fresh outdoor air. (If prescribed by local regulations) A potential zero offset can be read out by use of the Service tool.

Trip test with reference gas (If prescribed by local regulations)

The sensor is gassed with reference gas (for this you need a gas bottle with pressure regulator and a calibration adapter).

In doing so, the set alarm thresholds are exceeded, and all output functions are activated. It is necessary to check if the connected output functions are working correctly (e.g. the horn sounds, the fan switches on, devices shut down). By pressing the push-button on the horn, the horn acknowledgment must be checked. After removal of the reference gas, all outputs must automatically return to its initial position.

Other than the simple functional testing, it is also possible to perform a functional test by means of calibration. For further information, please refer to the User Manual.

Controller Unit multiple GDU commissioning

For fast and comfortable commissioning we recommend proceeding as follows. Especially the given specifications of the field bus cable have to be checked carefully, because it is here where most of the causes for problems in the field bus communication appear.

1. Optical Check

- Right cable type used (JY(St)Y 2x2x0.8LG or better).
- Cable topology and cable length.
- Correct mounting height of the sensors
- Correct connection at each GDU according to fig. 8
- Termination with 560 ohm at the beginning and at the end of each segment.
- Pay special attention so that the polarities of BUS_A and BUS_B are not reversed!

2. Check Short-circuit / Interruption / Cable Length of the Field Bus (see fig. 8.1)

This procedure has to be executed for each single segment. The field bus cable must be laid at the connector terminal block of the GDU for this testing. The plug, however, is not yet plugged into the GDU.

Disconnect the field bus leads from the Controller Unit central control. Connect ohmmeter to the loose leads and measure the total loop resistance. See fig. 8.1 The total loop resistance is calculated as follows:

- $R(\text{total}) = R(\text{cable}) + 560 \text{ Ohm}$ (terminating resistance)
- $R(\text{cable}) = 72 \text{ Ohm} / \text{km}$ (loop resistance) (cable type JY(St)Y 2x2x0.8LG)

R (total) (ohm)	Cause	Troubleshooting
< 560	Short-circuit	Look for short-circuit in the field bus cable.
infinite	Open-circuit	Look for interruption in the field bus cable.
> 560 < 640	Cable is o.k.	--

The allowed cable length can be calculated in a sufficiently exact way according to the following formula.

$$\text{Total cable length (km)} = (R(\text{total}) - 560 \text{ Ohm}) / 72 \text{ Ohm}$$

If the field bus cable is OK, reconnect it to the central unit.

3. Check Voltage and Bus Polarity of the Field Bus (see fig. 8.2 and 8.3)

- Bus connector to be plugged into each GDU.
- Switch operating voltage on at the Controller Unit central unit.
- The green LED at the GDU lights up weakly when operating voltage is applied (voltage indicator).
- Check operating voltage and bus polarity at each GDU according to fig. 7.1 and 7.2. $U_{\text{min}} = 16 \text{ V DC}$ (20V DC for Heavy Duty)
- Bus polarity:
Measure tension BUS_A against 0V DC and BUS_B against 0V DC. $U_{\text{BUS_A}} = \text{ca. } 0.5 \text{ V} > U_{\text{BUS_B}}$
 $U_{\text{BUS_B}} = \text{ca. } 2 - 4 \text{ V DC}$ (depending on the number of GDU and on the cable length)

4. Addressing of the GDU

After having checked the field bus successfully, you have to assign a basic communication address to each GDU via the display on the unit, the service tool or the PC tool. With this basic address, the data of the Sensor Cartridge assigned to input 1 are sent via the field bus to the gas controller. Any further sensor connected / registered on the GDU automatically gets the next address.

Choose the menu Address and enter the predetermined Address according to the Bus Address Plan.

If this connection is OK, you can read the current GDU address in the menu "Address" either at the display on the unit or by plugging in the service tool or the PC tool.

0 = Address of new GDU

XX = Current GDU address (permissible address range 1 – 96)

The detailed description of the addressing can be taken from the user manual of the Controller unit or the Controller unit service tool.

Further documentation:



Danfoss A/S

Climate Solutions • danfoss.com • +45 7488 2222

Any information, including, but not limited to information on selection of product, its application or use, product design, weight, dimensions, capacity or any other technical data in product manuals, catalogues descriptions, advertisements, etc. and whether made available in writing, orally, electronically, online or via download, shall be considered informative, and is only binding if and to the extent, explicit reference is made in a quotation or order confirmation. Danfoss cannot accept any responsibility for possible errors in catalogues, brochures, videos and other material. Danfoss reserves the right to alter its products without notice. This also applies to products ordered but not delivered provided that such alterations can be made without changes to form, fit or function of the product.

All trademarks in this material are property of Danfoss A/S or Danfoss group companies. Danfoss and the Danfoss logo are trademarks of Danfoss A/S. All rights reserved.