

# HGX56e/1155-4 S

Engine: 380-420V Y/YY -3- 50Hz PW

Refrigerant: R404A, R507

**Subject:**

## Performance data

### Application: Refrigeration & AC

Refrigerant	R404A, R507	Compressor refrigeration capacity	51.40 kW
Reference temperature	Dew point	Evaporator refrigeration capacity	51.40 kW
Power supply	50 Hz, 400 V	Power consumption	22.70 kW
Supply frequency	50 Hz	Current draw (400 V)	44.80 A
Evaporating temperature	-10.0 °C	Coefficient of performance (COP/EER)	2.26
<i>Evaporating pressure (abs.)</i>	<i>4.34 bar</i>	Condensing capacity	74.10 kW
Condensing temperature	45.0 °C	Mass flow	0.428 kg/s
<i>Condensing pressure (abs.)</i>	<i>20.47 bar</i>	Discharge end temperature	92.0 °C <sup>1)</sup>
Suction gas temperature	20 °C		
Subcooling (outside cond.)	0 K		
Usable superheat	100%		

*Preliminary capacity data.*

- 1) The stated value of the discharge end temperature is a mere calculated value. Additional cooling and heat dissipation are not considered. Deviations (particularly in deep freezing applications) from the real measured discharge temperature during operation are possible.

Subject to change without notice

To: [venolia.stoffels@metraclark.co.za](mailto:venolia.stoffels@metraclark.co.za)

From:

02.08.2022  
Page 1 of 11

VAP 11.12.0

# HGX56e/1155-4 S



Engine: 380-420V Y/YY -3- 50Hz PW

Refrigerant: R404A, R507

Subject:

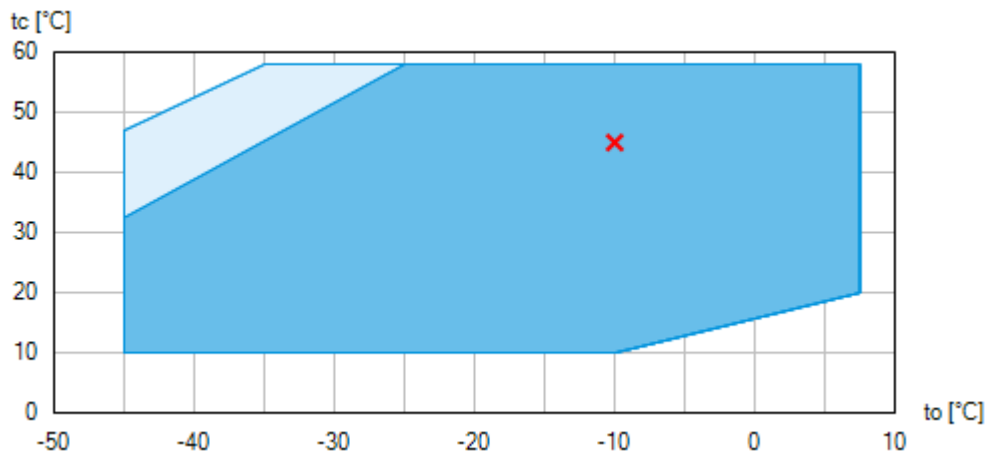
## Operating limits



-  Unlimited application range
-  Supplementary cooling or reduced suction gas temperature ( $\Delta t_{oh} < 20K$ )

Compressor operation is possible within the limits shown on the diagrams of application. Please note the coloured areas. Compressor application limits should not be chosen for design purposes or continuous operation. Axis values refer to dew point (saturated vapour line).

Subject to change without notice

To: venolia.stoffels@metraclark.co.za

From:

02.08.2022  
Page 2 of 11

VAP 11.12.0

# HGX56e/1155-4 S

Engine: 380-420V Y/YY -3- 50Hz PW

Refrigerant: R404A, R507

**Subject:**

## Technical data

Number of cylinders / Bore / Stroke	6 / 70 mm / 50 mm
Displacement 50/60 Hz (1450/1740 1/min)	100,4 / 120,5 m <sup>3</sup> /h
Voltage <sup>1)</sup>	380-420V Y/YY -3- 50Hz PW
	440-480V Y/YY -3- 60Hz PW
Winding divided into	50% / 50%
Max. working current <sup>2)</sup>	58.3 A
Max. power consumption <sup>2)</sup>	33.3 kW
Starting current (rotor blocked) <sup>2)</sup>	196.0 / 335.0 A
Motor protection	INT69 G
Protection terminal box	IP 66
Weight	221 kg
Frequency range <sup>3)</sup>	25 - 70 Hz
Max. permissible overpressure (g) (LP/HP) <sup>4)</sup>	19 / 28 bar
Connection suction line SV	54 mm - 2 1/8 "
Connection discharge line DV	35 mm - 1 3/8 "
Lubrication	Oil pump
Oil type R134a, R404A, R407A/C/F, R448A, R449A, R450A, R513A	BOCKlub E55
Oil type R22	BOCKlub A46
Oil charge	3,2 Ltr.
Oil sump heater	230 V - 1 - 50/60 Hz, 160 W
Dimensions Length / Width / Height	740 / 436 / 429 mm
Sound power level L <sub>WA</sub> <sup>5)</sup>	87 db(A) @ -35/+40 °C
	82 db(A) @ -10/+45 °C
	80 db(A) @ +5/+50 °C
Sound pressure level L <sub>pA</sub> <sup>5)</sup>	74 db(A) @ -35/+40 °C
	68 db(A) @ -10/+45 °C
	66 db(A) @ +5/+50 °C

Subject to change without notice

To: venolia.stoffels@metraclark.co.za

From:

02.08.2022  
Page 3 of 11

VAP 11.12.0

# HGX56e/1155-4 S

Engine: 380-420V Y/YY -3- 50Hz PW

Refrigerant: R404A, R507

## Subject:

---

- 1) Tolerance ( $\pm 10\%$ ) relates to the mean value of the voltage range. Other voltages and current types on request  
  
All data are based on voltage rms values  
  
PW = part winding, motors for part winding starting  
(no start unloaders required)  
Designs for Y/D on request
- 2) - The stated value for the max. power consumption is valid for the adjusted power supply.  
  
- Starting current (rotor blocked):
  - Part winding (PW) motors: Winding 1 / Winding 1+2
  - Delta/Star ( $\Delta/Y$ ) motors:  $\Delta / Y$- Take account of the max. operating current / max. power consumption for designing motor contractors, feed lines, fuses and motor protection switches. Motor contractors: Consumption category AC3.
- 3) The maximum permissible working current of the compressor ( $I_{max}$ ) must not be exceeded. Take account of the guidelines for use of frequency inverter (see compressor assembly instruction or selection software).
- 4) LP = Low pressure  
HP = High pressure
- 5) Declared dual-number noise emission values are in accordance with ISO 4871. The corresponding uncertainty to the sound power level is  $K_{WA} = 2,5$  dB and to the sound pressure level is  $K_{pA} = 2,5$  dB. The values are valid for 50 Hz with the refrigerant R404A at the standard rating points according to EN 12900.
  - A-weighted sound power level  $L_{WA}$  (re 1 pW), in decibel. To determine the values, measurement methods of the ISO 3740 standard with accuracy class 2 or higher were used .
  - A-weighted sound pressure level  $L_{pA}$  (re 20  $\mu$ Pa), in decibel. The values are calculated from the sound power level in accordance with ISO 11203:  $L_{pA} = L_{WA} - Q_2$  at a distance of  $d = 1$ m to the reference box.

---

Subject to change without notice

To: venolia.stoffels@metraclark.co.za

From:

02.08.2022  
Page 4 of 11

VAP 11.12.0

# HGX56e/1155-4 S

Engine: 380-420V Y/YY -3- 50Hz PW

Refrigerant: R404A, R507

Subject:

## Performance data table

Application: Refrigeration & AC

Reference temperature: Dew point

Supply frequency: 50 Hz

Voltage: 400 V

Suction gas temperature: 20 °C

Subcooling (outside cond.): 0 K

tc [°C]		to [°C]									
		0.0	-5.0	-10.0	-15.0	-20.0	-25.0	-30.0	-35.0	-40.0	-45.0
10.0	Q [W]			87400	71700	58200	46700	36900	28800	22100	16500
	P [kW]			10.90	11.60	11.70	11.50	10.90	10.00	8.91	7.65
	I [A]			33.90	34.30	34.50	34.30	33.80	33.20	32.50	31.80
15.0	Q [W]		99500	82400	67500	54700	43800	34500	26700	20300	14900
	P [kW]		12.70	13.40	13.50	13.30	12.70	11.70	10.60	9.27	7.84
	I [A]		35.20	35.70	35.90	35.70	35.20	34.50	33.60	32.70	31.90
20.0	Q [W]	113000	93500	77300	63300	51200	40800	32100	24700	18500	13400
	P [kW]	14.60	15.30	15.50	15.20	14.60	13.60	12.40	11.00	9.50	7.92
	I [A]	36.70	37.40	37.50	37.30	36.70	35.90	35.00	33.90	32.90	31.90
25.0	Q [W]	105000	87500	72200	59000	47600	37900	29600	22700	16800	11800
	P [kW]	17.40	17.60	17.40	16.70	15.70	14.40	12.90	11.30	9.63	7.93
	I [A]	39.30	39.50	39.30	38.60	37.70	36.60	35.40	34.10	33.00	31.90
30.0	Q [W]	97900	81500	67100	54700	44000	34900	27200	20700	15100	10300
	P [kW]	19.90	19.70	19.00	17.90	16.60	15.00	13.30	11.50	9.70	7.92
	I [A]	41.80	41.60	40.80	39.80	38.50	37.10	35.70	34.30	33.00	31.90
35.0	Q [W]	90700	75300	61900	50400	40400	32000	24800	18600	13400	8780
	P [kW]	22.20	21.50	20.40	19.00	17.30	15.50	13.60	11.60	9.74	7.90
	I [A]	44.30	43.50	42.30	40.80	39.20	37.50	35.90	34.40	33.00	31.90
40.0	Q [W]	83500	69100	56700	46000	36800	29000	22300	16600	11700	7310
	P [kW]	24.20	23.10	21.60	19.90	18.00	15.90	13.80	11.70	9.78	7.92
	I [A]	46.60	45.30	43.60	41.80	39.80	37.90	36.10	34.50	33.10	31.90
45.0	Q [W]	76100	62900	51400	41600	33100	26000	19800	14600	9970	5870
	P [kW]	26.00	24.50	22.70	20.70	18.50	16.30	14.10	11.90	9.86	8.00
	I [A]	48.80	46.90	44.80	42.60	40.40	38.20	36.30	34.60	33.10	32.00
50.0	Q [W]	68700	56500	46000	37100	29400	22900	17400	12600	8300	
	P [kW]	27.70	25.80	23.70	21.40	19.00	16.60	14.30	12.00	10.00	
	I [A]	50.80	48.50	46.00	43.40	40.90	38.60	36.50	34.70	33.20	
55.0	Q [W]	61200	50100	40700	32600	25700	19900	14900	10600		
	P [kW]	29.20	27.00	24.60	22.10	19.50	17.00	14.60	12.30		
	I [A]	52.80	50.00	47.00	44.10	41.40	38.90	36.70	34.90		

*Preliminary capacity data.*



Supplementary cooling or reduced suction gas temperature ( $\Delta t_{oh} < 20K$ )

to Evaporating temperature  
tc Condensing temperature  
Q Compressor refrigeration capacity  
P Power consumption  
I Current draw

Subject to change without notice

To: venolia.stoffels@metraclark.co.za

From:

02.08.2022  
Page 5 of 11

VAP 11.12.0

## HGX56e/1155-4 S

Engine: 380-420V Y/YY -3- 50Hz PW

Refrigerant: R404A, R507

**Subject:**

---

### Scope of supply

Semi-hermetic six-cylinder reciprocating compressor with drive motor  
Single-section compressor housing with hermetically integrated electric motor

Rear bearing flange prepared for oil differential pressure sensor DELTA-P II

Winding protection with PTC resistor sensors and electronic trigger unit INT69 G  
115-230 V AC, 50/60 Hz, IP00

Oil pump

Possibility of connection of oil level controllers ESK, AC+R or CARLY

Possibility of connection of oil level controllers Traxoil <sup>1)</sup>

Possibility for connection of oil pressure safety switch MP54

Oil charge:

HG: **BOCK**lub A46

HGX: **BOCK**lub E55

Sight glass

Pressure relief valve

Suction and discharge line valve

Inert gas charge

### Accessories

(Digital) capacity regulator DCR14 230 V - 1 - 50/60 Hz, IP65  
possible equipment see Capacity regulator 09900-DGbF

Cylinder cover prepared for digital capacity regulator

Oil sump heater 230 V - 1 - 50/60 Hz, 160 W

USB converter for INT69 G Diagnose <sup>2)</sup>

Oil temperature sensor (Pt1000, for external evaluation)

Thermal protection thermostat per cylinder cover

Oil pressure safety switch MP54 230 V - 1 - 50/60 Hz, IP20 <sup>2)</sup>

Oil differential pressure sensor DELTA-P II 220-240 V - 1 - 50/60 Hz <sup>2)</sup>

Connection piece suction and discharge valve in welding design

INT69 G Diagnose 115-230 V AC, 50/60 Hz, IP00 (INT69 G not applicable)

DP-Modbus Gateway 115-230 V AC, 50/60 Hz, IP00 including adapter cable <sup>2)</sup>

Subject to change without notice

---

To: venolia.stoffels@metraclark.co.za

From:

02.08.2022  
Page 6 of 11

VAP 11.12.0

## HGX56e/1155-4 S

Engine: 380-420V Y/YY -3- 50Hz PW

Refrigerant: R404A, R507

### Subject:

---

Modbus-LAN Gateway 230 V AC, 50/60 Hz, IP00 <sup>2)</sup>

#### Additional fan

230 V AC - 1 - 50 Hz, 97 W, IP44

230 V AC - 1 - 60 Hz, 128 W <sup>2)</sup>

Injection nozzle for liquid injection <sup>2)</sup>

4 anti-vibration pads enclosed

Special voltage and/or frequency (on request)

---

1) Only with additional adapter possible

2) Enclosure

---

Subject to change without notice

To: [venolia.stoffels@metraclark.co.za](mailto:venolia.stoffels@metraclark.co.za)

From:

02.08.2022  
Page 7 of 11

VAP 11.12.0

## HGX56e/1155-4 S

Engine: 380-420V Y/YY -3- 50Hz PW

Refrigerant: R404A, R507

**Subject:**

---

### Dimensions and connections

---

Subject to change without notice

To: [venolia.stoffels@metraclark.co.za](mailto:venolia.stoffels@metraclark.co.za)

From:

02.08.2022  
Page 8 of 11

VAP 11.12.0



# HGX56e/1155-4 S

Engine: 380-420V Y/YY -3- 50Hz PW

Refrigerant: R404A, R507

Subject:

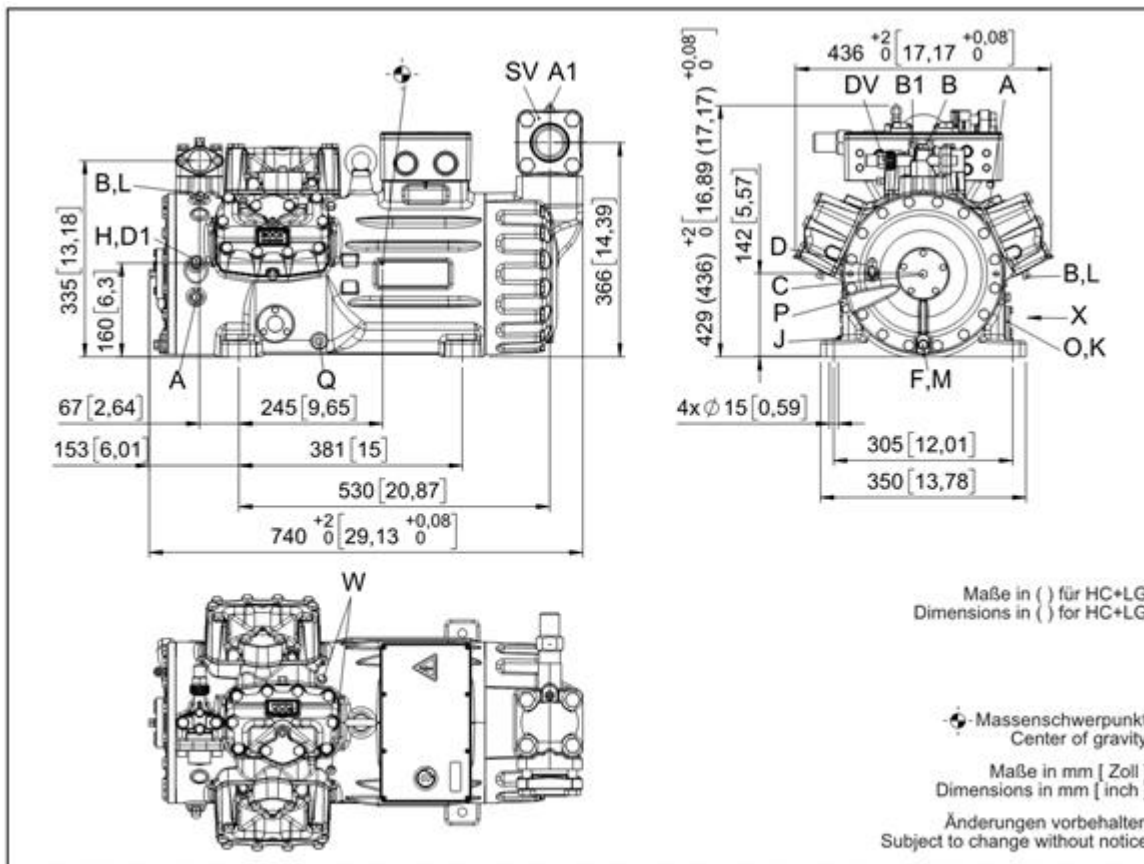

### Maße Zubehör / Dimensions Accessories

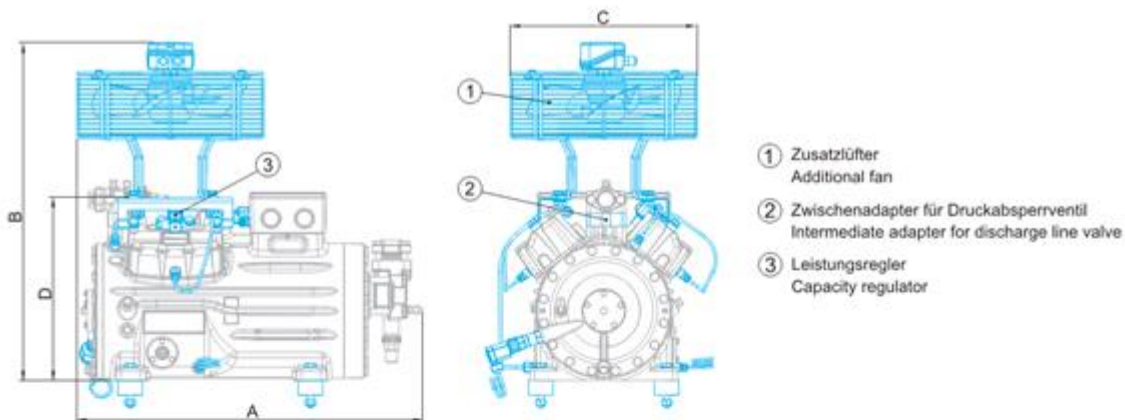

Typ / Type	A mm / inch	B mm / inch	C mm / inch	D mm / inch
HG12P	ca. 460 / 18	ca. 500 / 20	ca. 315 / 12	-
HG22e	ca. 525 / 21	ca. 610 / 24	ca. 380 / 15	-
HG34e	ca. 580 / 23	ca. 640 / 25	ca. 380 / 15	-
HG44e	ca. 710 / 28	ca. 685 / 27	ca. 380 / 15	368 / 14
HG56e	-	ca. 710 / 28	ca. 380 / 15	-
HG66e	ca. 820 / 32	ca. 800 / 31	ca. 380 / 15	-

Ansicht X: Anschlussmöglichkeit für Ölspiegelregulator  
View X: Possibility of connection of oil level regulator



- Drelllochanschluss für TRAXOIL (3xM6x10)  
Three-hole connection for TRAXOIL (3xM6x10)
- Drelllochanschluss für ESK, AC+R, CARLY (3xM6x10)  
Three-hole connection for ESK, AC+R, CARLY (3xM6x10)

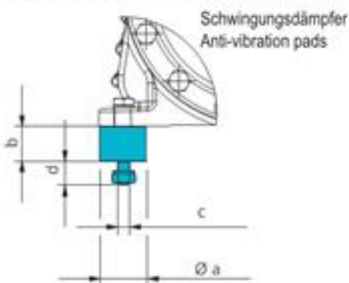

Typ / Type	Øa mm / inch	b mm / inch	c mm / inch	d mm / inch
HG12P	30 / 1.2	30 / 1.2	M8	20 / 0.8
HG22e	40 / 1.6	30 / 1.2	M10	20 / 0.8
HG34e	40 / 1.6	30 / 1.2	M10	20 / 0.8
HG44e	50 / 2.0	30 / 1.2	M12	25 / 1.0
HG56e	50 / 2.0	30 / 1.2	M12	25 / 1.0
HG66e	50 / 2.0	30 / 1.2	M12	25 / 1.0
HG88e	70 / 2.8	45 / 1.8	M12	37 / 1.5

ange without notice

# HGX56e/1155-4 S

Engine: 380-420V Y/YY -3- 50Hz PW

Refrigerant: R404A, R507

**Subject:**

SV	Suction line valve, tube $\varnothing$ <sup>1)</sup>	54 mm - 2 1/8 "
DV	Discharge line valve, tube $\varnothing$ <sup>1)</sup>	35 mm - 1 3/8 "
A	Connection suction side, not lockable	1/8 " NPTF
A1	Connection suction side, lockable	7/16 " UNF
B	Connection discharge side, not lockable	1/8 " NPTF
B1	Connection discharge side, lockable	7/16 " UNF
C	Connection oil pressure safety switch OIL	1/8 " NPTF
D	Connection oil pressure safety switch LP	7/16 " UNF
D1	Connection oil return from oil separator	1/4 " NPTF
F	Oil drain	M 12 x 1.5
H	Oil charge plug	1/4 " NPTF
J	Connection oil sump heater	3/8 " NPTF
K	Sight glass	3 x M 6
L	Connection thermal protection thermostat	1/8 " NPTF
M	Oil strainer	M 12 x 1.5
O	Connection oil level regulator	3 x M 6
P	Connection oil differential pressure sensor	M 20 x 1.5
Q	Connection oil temperature sensor	1/8" NPTF
W	Connection for refrigerant injection	2 x 1/8 " NPTF

1) Brazing connection

Subject to change without notice

To: venolia.stoffels@metraclark.co.za

From:

02.08.2022  
Page 10 of 11

VAP 11.12.0

## HGX56e/1155-4 S

Engine: 380-420V Y/YY -3- 50Hz PW

Refrigerant: R404A, R507

**Subject:**

---

**BOCK** colour the world  
of tomorrow

### Product photo



Subject to change without notice

---

To: [venolia.stoffels@metraclark.co.za](mailto:venolia.stoffels@metraclark.co.za)

From:

02.08.2022  
Page 11 of 11

VAP 11.12.0