

Carrier R410A T1 380V 50Hz 3Ph Split Type Technical Manual



MODEL

38LDU-70HN1/42LDU-70HN1
38LDU1-96HN1/42LDU1-96HN1
38LDU-140HN1/42LDU-140HN1
38LDU-170HN1/42LDU-170HN1
38LDU-76HN1/42CFS-76HN1
38LDU1-96HN1/42CFS1-96HN1

Carrier reserves the right to discontinue, or change specification or designs at any time without notices and without incurring obligations.

Content

Part. 1 General information.....	3
Part. 2 Hi-static Pressure Duct Indoor Unit.....	6
Part. 3 Floor-standing Indoor Unit	29
Part. 4 Outdoor Unit.....	42
Part. 5 Installation.....	55
Part. 6 Controller.....	105

Part. 1 General information

1. Model Names of Indoor/Outdoor Units	4
2. External Appearance	4

1. Model Names of Indoor/Outdoor Units

Type	Indoor unit		Outdoor unit		Capacity	
	Model	Power supply	Model	Power supply	Cooling	Heating
					kW	kW
Hi-static pressure duct type	42LDU-70HN1	220-240V~1 Ph,50Hz	38LDU-70HN1	380-415V~ 3Ph,50Hz	20.5	25
	42LDU1-96HN1		38LDU1-96HN1		28.1	31.1
	42LDU-140HN1		38LDU-140HN1		41.0	47
	42LDU-170HN1		38LDU-170HN1		49.5	60.1
Floor standing type	42CFS-76HN1		38LDU-76HN1		22.6	25
	42CFS1-96HN1		38LDU1-96HN1		28.1	31.1

2. External Appearances

2.1 Indoor units

42LDU-70HN1, 42LDU1-96HN1	42LDU-140HN1, 42LDU-170HN1	42CFS-76HN1, 42CFS1-96HN1
		

2.2 Outdoor unit

38LDU70HN1, 38LDU-76HN1, 38LDU1-96HN1



38LDU-140HN1



38LDU-170HN1



Part. 2 Hi-static Pressure Duct Indoor Unit

1. Features	7
2. Specifications.....	8
3. Dimensions (Unit: mm)	9
4. Service Space.....	10
5. Refrigerant circuits	11
6. Wiring Diagrams	12
7. Capacity Tables	14
8. Static Pressure Curve	22
9. Electric Characteristics	24
10. Sound Levels	24
11. Accessories	25

1. Features

- ✧ High capacity of cooling and heating, and energy saving.
- ✧ Thin size, even can installed at limited place.
- ✧ All round steel shell, for high quality protection of transportation.
- ✧ Convenient installation, hidden in the ceiling, unit installation is not hindered by the location of lighting fixtures or room structure.
- ✧ Air inlet and outlet flanges are standard and easy for duct connection.

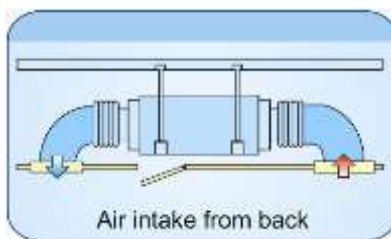

- ✧ External static pressure is up to 196Pa. The maximum distance of air supply is about 14m.
- ✧ Multi diffusers from one indoor unit supply airflow to multi rooms at the same time. The unit is suitable for various applications where there are many rooms or halls, such as restaurants, connect halls and hotels.

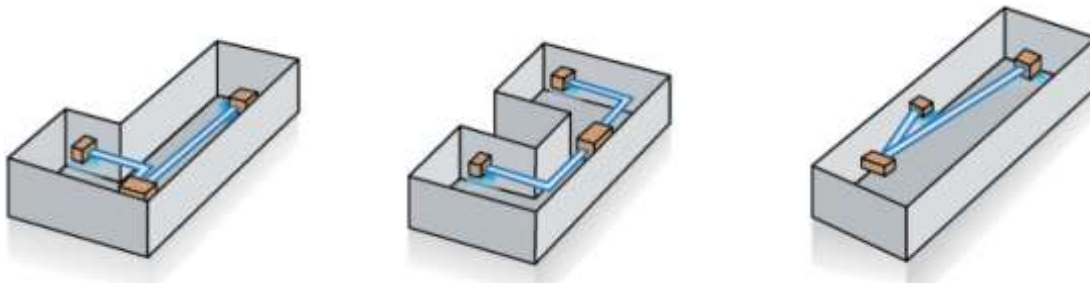

- ✧ High efficient scroll compressor, with thermal protectors to prevent motor overheating.
- ✧ Single refrigerant system, only one group refrigerant pipe, easy to installation.

2. Specifications

Model			42LDU-70HN1	42LDU1-96HN1	42LDU-140HN1	42LDU-170HN1
Power supply		\	220-240V~, 1Ph, 50Hz		220-240V~, 1Ph, 50Hz	
Cooling	Capacity	Btu/h	70,000	96,000	140,000	169,000
		W	20,500	28,100	41,000	49,500
	Input	W	8,100	9,600	17,500	21,500
	EER	W/W	2.53	2.93	2.34	2.30
Heating	Capacity	Btu/h	85,300	106,000	160,300	200,000
		W	25,000	31,100	47,000	60,100
	Input	W	7,500	10,300	16,000	20,500
	COP	W/W	3.33	3.02	2.94	2.93
Rated input (Indoor unit)		W	1,300	1,400	2,730	4,690
Rated current (Indoor unit)		A	5.2	5.8	12.1	20.9
Indoor air flow (m ³ /h/CFM)		\	4,500 (2,647)	5,100 (3,000)	8,500 (5,000)	10,800 (6,354)
Indoor standard ESP		Pa	196	196	196	196
Indoor noise level		dB(A)	56	56	63	65
Refrigerant type		\	R410A	R410A	R410A	R410A
Refrigerant control		\	Capillary		Capillary	
Fan	Type	\	Centrifugal fan	Centrifugal fan	Centrifugal fan	Centrifugal fan
	Motor model (xQty.)	\	YDK300-4X(x2)	YDK550-4X(x2)	YDK300-4X(x3)	YDK600-4C(x3)
	Input (Hi/med/lo)	W	720/605/510	910/780/680	720/605/510	1,130/990/850
	Capacitor	\	15μF/450V	20μF/450V	15μF/450V	20μF/450V
	Speed (Hi/med/lo)	r/min	1,040/930/825	1,320/1,230/1,120	1,040/930/825	1,280/1,135/975
Coil	Type	\	Copper tube and aluminum fin		Copper tube and aluminum fin	
	Tube size	mm	Φ7	Φ9.52	Φ7	Φ7
	No. of rows	\	4	4	4	4
	Fin spacing	mm	1.5	1.5	1.5	1.5
	Tube pitchx row pitch	mm	21x13.37	25.4x22	21x13.37	21x13.37
	Lengthx height	mm	1,202x378	1,202x406.4	1,602x588	1,602x588
	Number of circuits	\	14	16	42	28
Controller		\	WR-29B-CM	WR-29B-CM	WR-29B-CM	WR-29B-CM
Refrigerant pipe (Liquid/ Gas)		mm	Φ9.52/Φ22	Φ9.52/Φ25.4	Φ16/Φ32	Φ16/Φ32
Power wire		\	3x2.5mm ²	3x2.5mm ²	3x2.5mm ²	3x2.5mm ²
Signal wire		\	4x1.0mm ²	4x1.0mm ²	4x1.0mm ²	4x1.0mm ²
Drain pipe size		mm	Φ41	Φ41	Φ41	Φ41
Dimension (WxHxD)		mm	1,452x462x797		1,988x669x906	
Packing (WxHxD)		mm	1,555x500x875		2,095x800x964	
Net/Gross weight		kg	94/106	97/109	208/220	215/230

Notes:

1. Rated input = Max. input, Rated current = Max. input.

2. Nominal cooling capacities are based on the following conditions:

Indoor temp: 27°CDB, 19°CWB; Outdoor temp: 35°CDB, 24°CWB; Nominal heating capacities are based on the following conditions: Indoor temp: 20°CDB, 15°CWB; Outdoor temp: 7°CDB, 6°CWB.

3. Dimensions (Unit: mm)

42LDU-70HN1, 42LDU1-96HN1

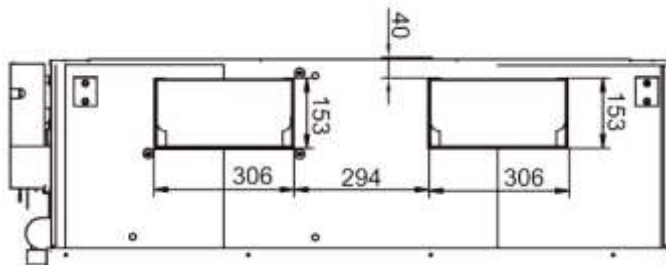

Air outlet side view

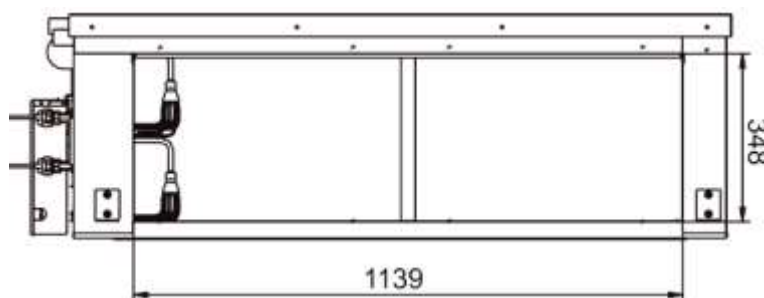

Air inlet side view

42LDU-140HN1

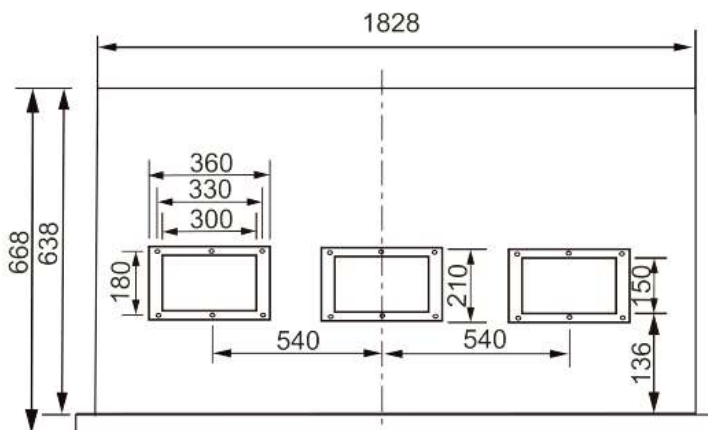

Air outlet side view

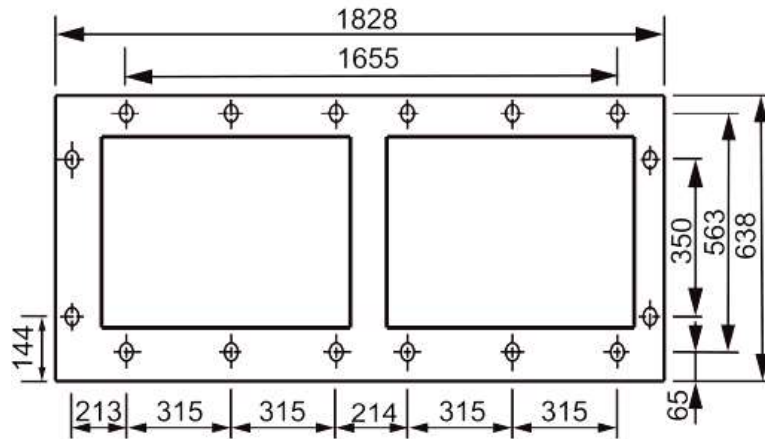

Air inlet side view

42LDU-170HN1

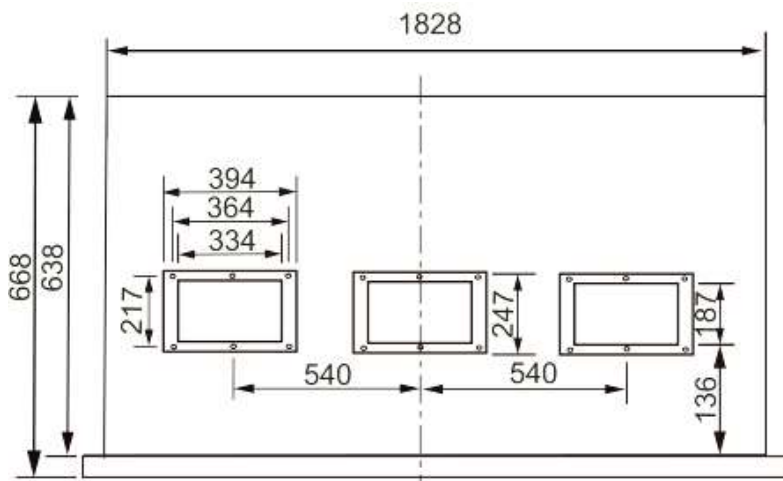

Air outlet side view

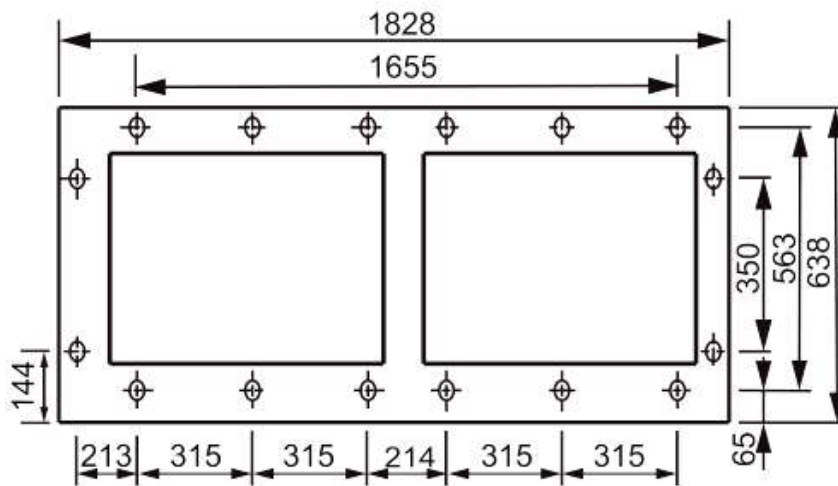

Air inlet side view

4. Service Spaces

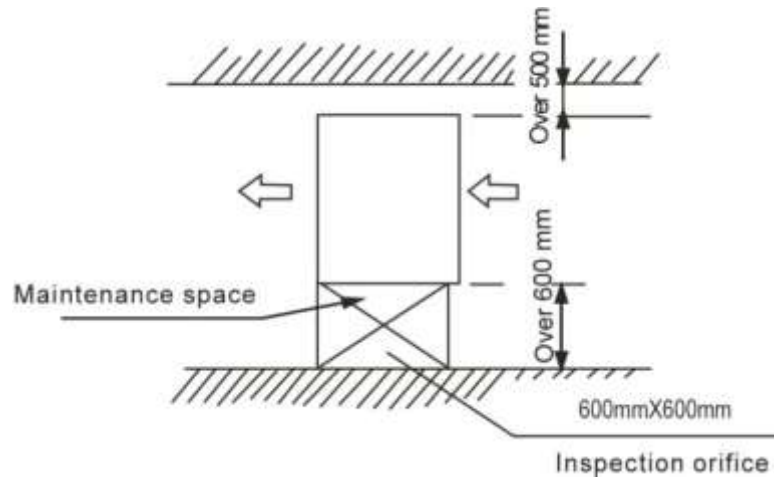

Top view

5. Refrigerant circuits

42LDU-70HN1, 42LDU1-96HN1:

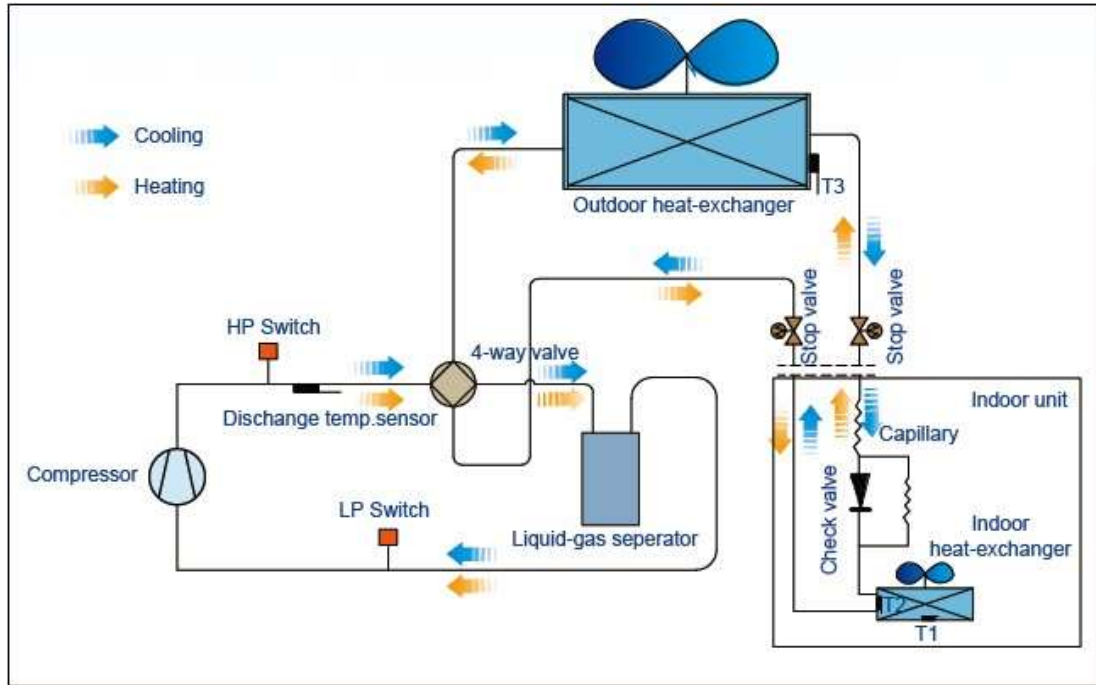

42LDU-140HN1, 42LDU-170HN1:

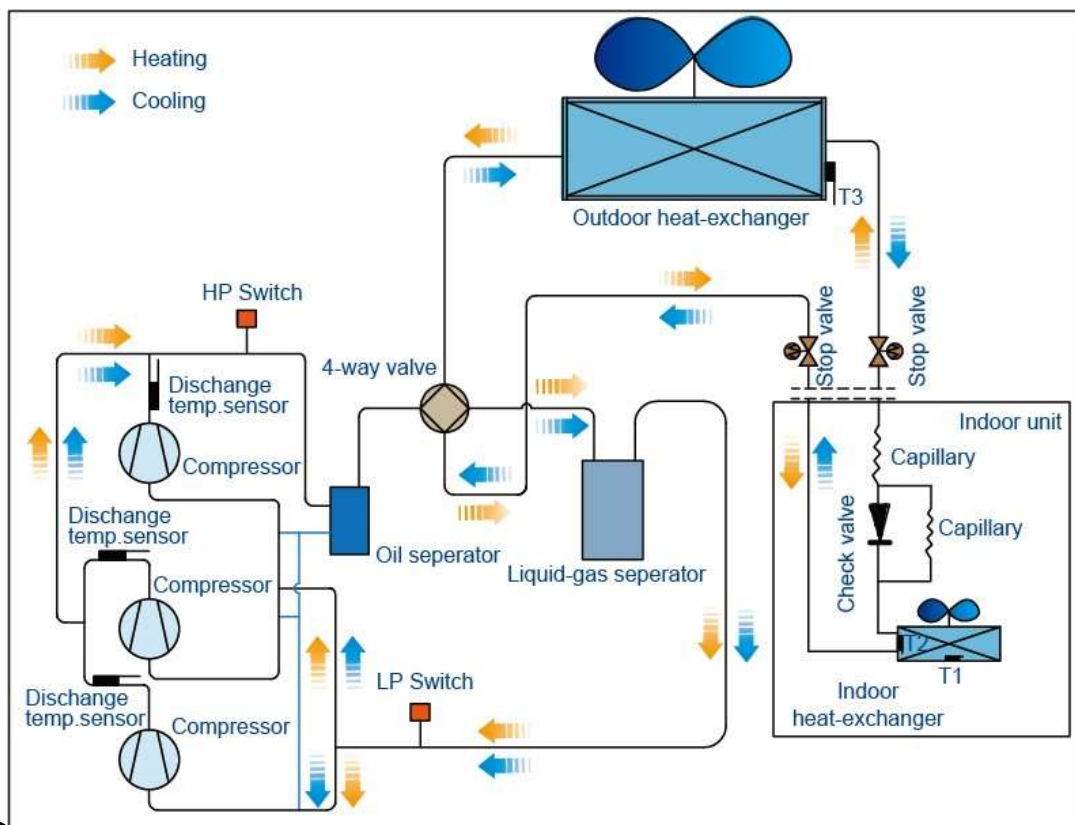

6. Wiring Diagrams

42LDU-70HN1

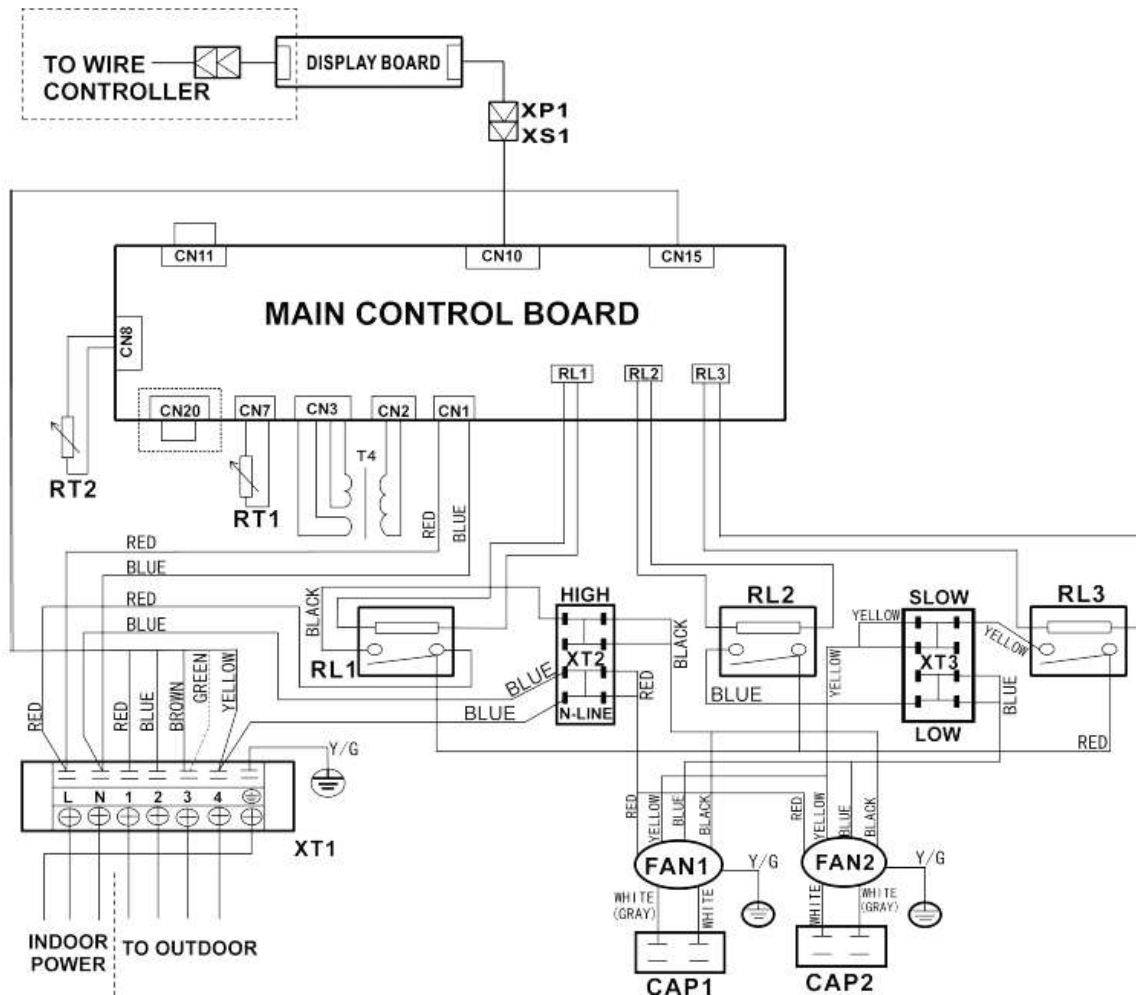

ITEM	NAME
CAP1, CAP2	INDOOR FAN CAP
CN1-CN3, CN7, CN8, CN10, CN11, CN15, CN20	PCB SOCKETS
T4	TRANSFORMER
FAN1, FAN2	INDOOR FAN
RT1	ROOM TEMP. SENSOR
RT2	PIPE TEMP. SENSOR
XP1	CONNECTOR
XS1	CONNECTOR
XT1	7-WAY TERMINAL
XT2, XT3	MID TERMINAL
RL1-RL3	RELAY

42LDU1-96HN1

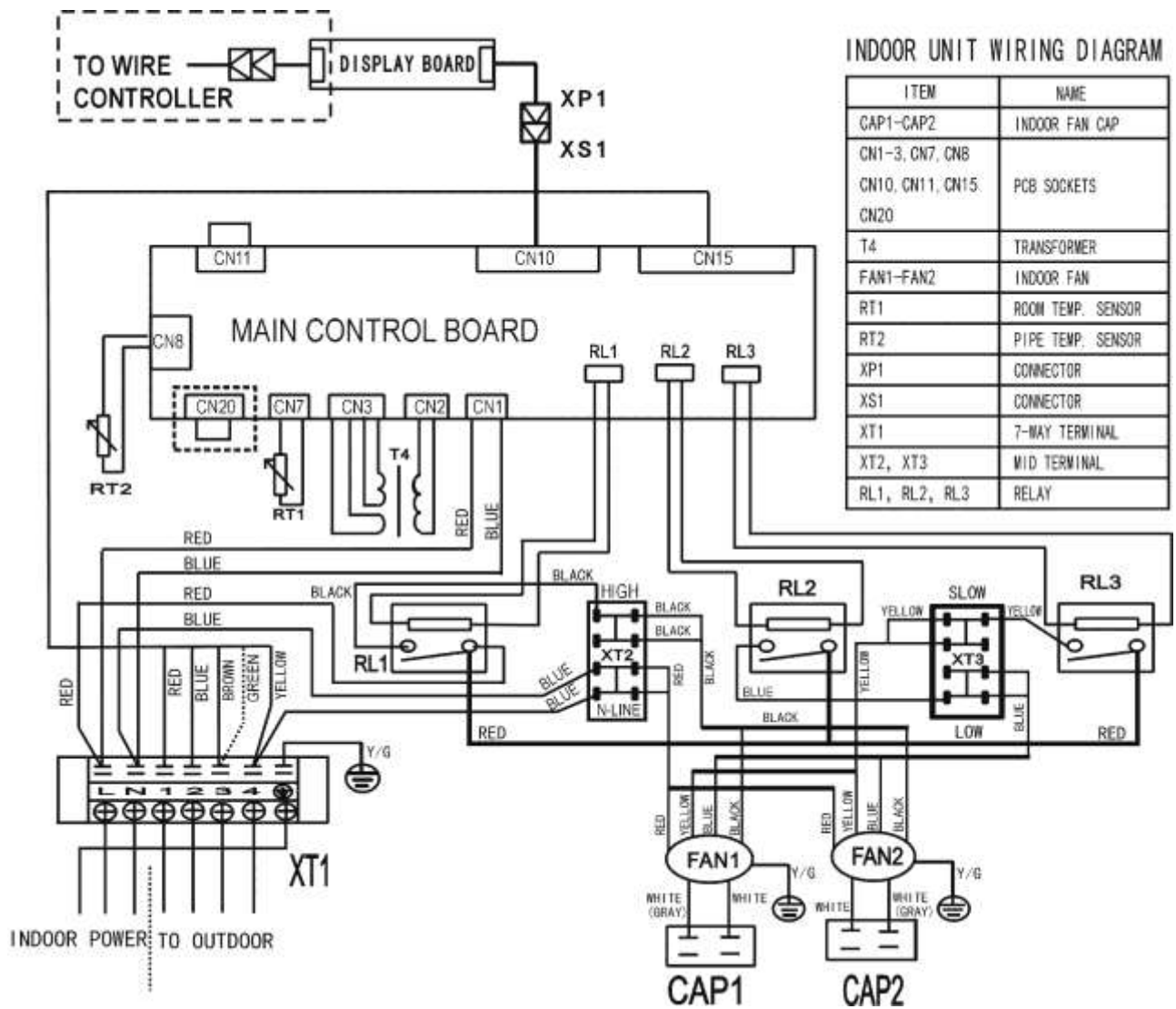

42LDU-140HN1, 42LDU-170HN1

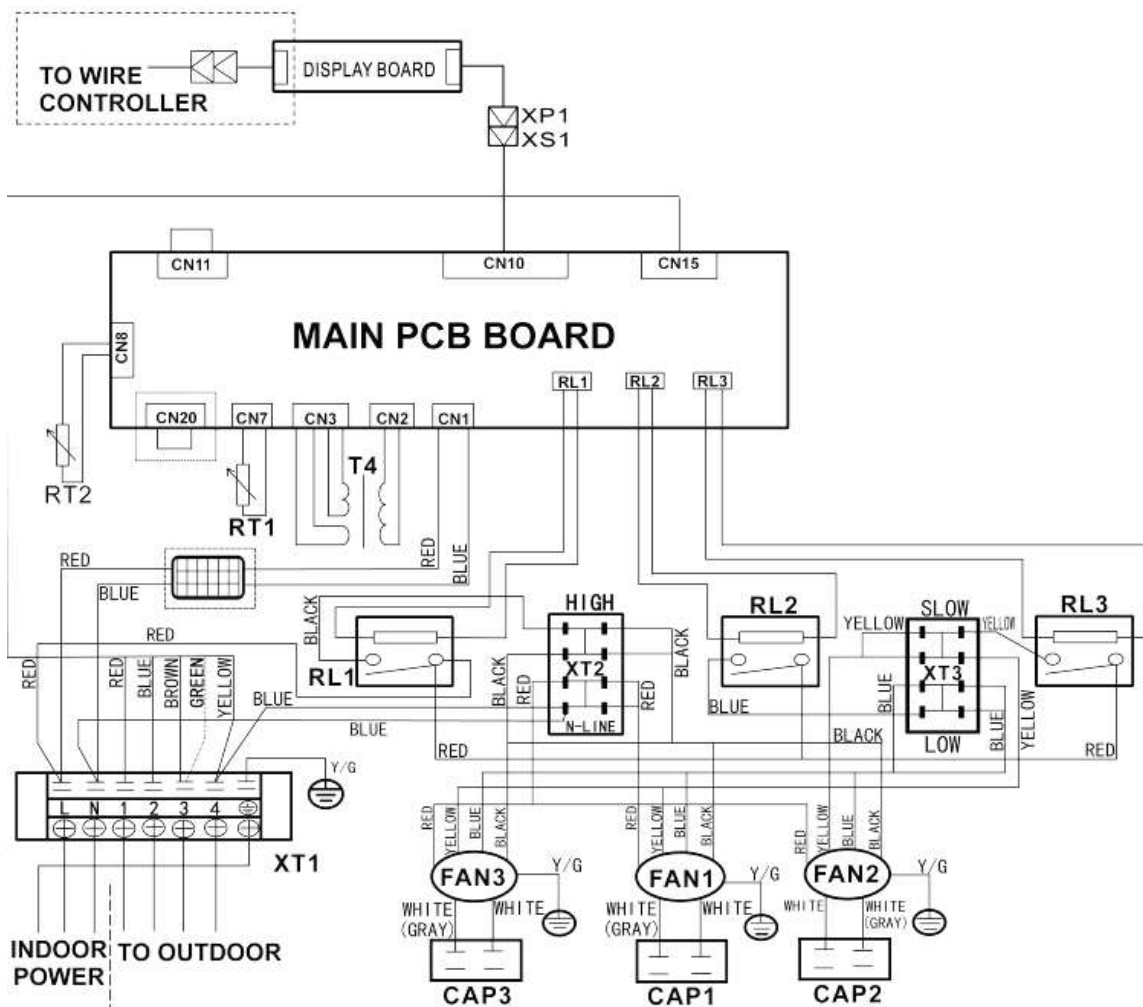

ITEM	NAME
CAP1, CAP2	INDOOR FAN CAP
CN1-CN3, CN7, CN8, CN10, CN11, CN15, CN20	PCB SOCKETS
T4	TRANSFORMER
FAN1, FAN2	INDOOR FAN
RT1	ROOM TEMP. SENSOR
RT2	PIPE TEMP. SENSOR
XP1	CONNECTOR
XS1	CONNECTOR
XT1	7-WAY TERMINAL
XT2, XT3	MID TERMINAL
RL1-RL3	RELAY

7. Capacity Tables

42LDU-70HN1

Gross Cooling Capacity (kW)																			
Outdoor DB(°C)		29.40									35.00								
Indoor	WB(°C)	16.10			19.40			22.80			16.10			19.40			22.80		
CFM	DB(°C)	TC	SC	PI	TC	SC	PI	TC	SC	PI	TC	SC	PI	TC	SC	PI	TC	SC	PI
2200	23.90	15.30	10.20	4.38	16.07	10.71	4.60	16.87	11.25	4.83	14.85	9.90	5.07	15.60	10.40	5.32	16.38	10.92	5.59
	26.70	15.91	12.24	4.55	16.71	12.85	4.78	17.54	13.49	5.02	15.45	11.88	5.27	16.22	12.48	5.54	17.03	13.10	5.81
	29.40	16.55	13.79	4.74	17.38	14.48	4.97	18.25	15.20	5.22	16.07	13.39	5.48	16.87	14.06	5.76	17.71	14.76	6.05
	32.20	17.21	15.65	4.93	18.07	16.43	5.17	18.97	17.25	5.43	16.71	15.19	5.70	17.54	15.95	5.99	18.42	16.75	6.29
2300	23.90	17.90	11.93	5.12	18.79	12.53	5.38	19.73	13.16	5.65	17.38	11.59	5.93	18.25	12.16	6.23	19.16	12.77	6.54
	26.70	18.62	14.32	5.33	19.55	15.04	5.59	20.52	15.79	5.87	18.07	13.90	6.17	18.98	14.60	6.48	19.93	15.33	6.80
	29.40	19.36	16.13	5.54	20.33	16.94	5.82	21.34	17.79	6.11	18.80	15.66	6.41	19.74	16.45	6.74	20.72	17.27	7.07
	32.20	20.13	18.30	5.76	21.14	19.22	6.05	22.20	20.18	6.35	19.55	17.77	6.67	20.53	18.66	7.01	21.55	19.59	7.36
2500	23.90	20.94	13.96	5.99	21.99	14.66	6.29	23.09	15.39	6.61	20.33	13.55	6.94	21.35	14.23	7.29	22.41	14.94	7.65
	26.70	21.78	16.75	6.23	22.87	17.59	6.55	24.01	18.47	6.87	21.14	16.26	7.22	22.20	17.08	7.58	23.31	17.93	7.96
	29.40	22.43	18.69	6.42	23.55	19.63	6.74	24.73	20.61	7.08	21.78	18.15	7.43	22.87	19.06	7.80	24.01	20.01	8.19
	32.20	23.10	21.00	6.61	24.26	22.05	6.94	25.47	23.16	7.29	22.43	20.39	7.66	23.55	21.41	8.04	24.73	22.48	8.44
2800	23.90	23.80	15.86	6.81	24.99	16.66	7.15	26.24	17.49	7.51	23.10	15.40	7.89	24.26	16.17	8.28	25.47	16.98	8.69
	26.70	24.51	18.85	7.02	25.74	19.80	7.37	27.02	20.79	7.73	23.80	18.30	8.12	24.99	19.22	8.53	26.24	20.18	8.95
	29.40	25.25	21.04	7.23	26.51	22.09	7.59	27.83	23.19	7.97	24.51	20.43	8.37	25.74	21.45	8.78	27.02	22.52	9.22
	32.20	26.00	23.64	7.44	27.30	24.82	7.82	28.67	26.06	8.21	25.25	22.95	8.62	26.51	24.10	9.05	27.83	25.30	9.50

Notes:

1. DB = Dry Bulb Temperature (°C), WB = Wet Bulb Temperature (°C)
2. TC = Total Capacity (kW)
3. SC = Sensible Capacity (kW)
4. PI = Power input (kW)

Carrier R410A T1 50Hz Split AC

Gross Cooling Capacity (kW)																			
Outdoor DB(°C)		40.60									46.10								
Indoor	WB(°C)	16.10			19.40			22.80			16.10			19.40			22.80		
CFM	DB(°C)	TC	SC	PI	TC	SC	PI	TC	SC	PI	TC	SC	PI	TC	SC	PI	TC	SC	PI
2200	23.90	13.58	9.05	6.59	14.26	9.50	6.92	14.97	9.98	7.26	13.18	8.79	7.63	13.84	9.23	8.01	14.53	9.69	8.41
	26.70	14.12	10.86	6.85	14.83	11.40	7.20	15.57	11.98	7.56	13.71	10.55	7.93	14.39	11.07	8.33	15.11	11.63	8.75
	29.40	14.69	12.24	7.13	15.42	12.85	7.48	16.19	13.49	7.86	14.26	11.88	8.25	14.97	12.48	8.66	15.72	13.10	9.10
	32.20	15.27	13.88	7.41	16.04	14.58	7.78	16.84	15.31	8.17	14.83	13.48	8.58	15.57	14.15	9.01	16.35	14.86	9.46
2300	23.90	15.88	10.59	7.71	16.68	11.12	8.09	17.51	11.67	8.50	15.42	10.28	8.92	16.19	10.79	9.37	17.00	11.33	9.84
	26.70	16.52	12.71	8.02	17.34	13.34	8.42	18.21	14.01	8.84	16.04	12.34	9.28	16.84	12.95	9.74	17.68	13.60	10.23
	29.40	17.18	14.32	8.34	18.04	15.03	8.75	18.94	15.78	9.19	16.68	13.90	9.65	17.51	14.59	10.13	18.39	15.32	10.64
	32.20	17.87	16.24	8.67	18.76	17.05	9.10	19.70	17.91	9.56	17.35	15.77	10.04	18.21	16.56	10.54	19.12	17.39	11.07
2500	23.90	18.58	12.39	9.02	19.51	13.01	9.47	20.49	13.66	9.94	18.04	12.03	10.44	18.94	12.63	10.96	19.89	13.26	11.51
	26.70	19.32	14.87	9.38	20.29	15.61	9.85	21.31	16.39	10.34	18.76	14.43	10.86	19.70	15.15	11.40	20.69	15.91	11.97
	29.40	19.90	16.59	9.66	20.90	17.42	10.14	21.94	18.29	10.65	19.32	16.10	11.18	20.29	16.91	11.74	21.31	17.75	12.33
	32.20	20.50	18.64	9.95	21.53	19.57	10.45	22.60	20.55	10.97	19.90	18.10	11.52	20.90	19.00	12.33	21.94	19.95	12.70
2800	23.90	21.12	14.08	10.25	22.17	14.78	10.76	23.28	15.52	11.30	20.50	13.67	11.86	21.53	14.35	12.70	22.60	15.07	13.08
	26.70	21.75	16.73	10.56	22.84	17.57	11.08	23.98	18.45	11.64	21.12	16.24	12.22	22.17	17.06	13.08	23.28	17.91	13.47
	29.40	22.40	18.67	10.87	23.52	19.60	11.42	24.70	20.58	11.99	21.75	18.13	12.59	22.84	19.03	13.47	23.98	19.98	13.88
	32.20	23.07	20.98	11.20	24.23	22.03	11.76	25.44	23.13	12.35	22.40	20.37	12.96	23.52	21.38	13.88	24.70	22.45	14.29

Notes:

1. DB = Dry Bulb Temperature (°C), WB = Wet Bulb Temperature (°C)
2. TC = Total Capacity (kW)
3. SC = Sensible Capacity (kW)
4. PI = Power input (kW)

42LDU1-96HN1

Gross Cooling Capacity (kW)																			
Outdoor DB(°C)		29.40									35.00								
Indoor	WB(°C)	16.10			19.40			22.80			16.10			19.40			22.80		
CFM	DB(°C)	TGC	SHC	PI	TGC	SHC	PI	TGC	SHC	PI	TGC	SHC	PI	TGC	SHC	PI	TGC	SHC	PI
2470	23.90	19.37	13.09	5.62	20.62	13.75	5.90	21.66	14.44	6.20	19.07	12.71	6.51	20.02	13.35	6.83	21.02	14.02	7.18
	26.70	20.14	15.71	5.85	21.45	16.50	6.14	22.52	17.32	6.45	19.83	15.26	6.77	20.82	16.02	7.11	21.87	16.82	7.46
	29.40	20.95	17.70	6.08	22.31	18.59	6.39	23.42	19.52	6.70	20.63	17.19	7.04	21.66	18.05	7.39	22.74	18.95	7.76
	32.20	21.78	20.09	6.32	23.20	21.09	6.64	24.36	22.15	6.97	21.45	19.50	7.32	22.52	20.48	7.69	23.65	21.50	8.07
2700	23.90	22.66	15.32	6.58	24.13	16.09	6.91	25.33	16.89	7.25	22.31	14.87	7.61	23.42	15.62	7.99	24.60	16.40	8.39
	26.70	23.56	18.38	6.84	25.09	19.30	7.18	26.35	20.27	7.54	23.20	17.85	7.92	24.36	18.74	8.31	25.58	19.68	8.73
	29.40	24.50	20.71	7.11	26.10	21.75	7.47	27.40	22.83	7.84	24.13	20.11	8.24	25.34	21.11	8.65	26.60	22.17	9.08
	32.20	25.49	23.50	7.40	27.14	24.67	7.77	28.50	25.91	8.16	25.10	22.81	8.56	26.35	23.95	8.99	27.67	25.15	9.44
3000	23.90	26.50	17.92	7.69	28.23	18.82	8.08	29.64	19.76	8.48	26.10	17.40	8.91	27.40	18.27	9.35	28.77	19.18	9.82
	26.70	27.56	21.51	8.00	29.36	22.58	8.40	30.82	23.71	8.82	27.14	20.88	9.26	28.50	21.92	9.73	29.93	23.02	10.21
	29.40	28.39	24.00	8.24	30.24	25.20	8.65	31.75	26.46	9.09	27.96	23.30	9.54	29.36	24.46	10.02	30.82	25.69	10.52
	32.20	29.24	26.96	8.49	31.14	28.31	8.91	32.70	29.73	9.36	28.80	26.18	9.83	30.24	27.49	10.32	31.75	28.86	10.84
3300	23.90	30.12	20.37	8.74	32.08	21.38	9.18	33.68	22.45	9.64	29.66	19.77	10.12	31.14	20.76	10.63	32.70	21.80	11.16
	26.70	31.02	24.20	9.01	33.04	25.41	9.46	34.69	26.69	9.93	30.55	23.50	10.43	32.08	24.67	10.95	33.68	25.91	11.50
	29.40	31.96	27.01	9.28	34.03	28.36	9.74	35.73	29.78	10.23	31.47	26.22	10.74	33.04	27.53	11.28	34.69	28.91	11.84
	32.20	32.91	30.35	9.56	35.05	31.86	10.03	36.80	33.46	10.53	32.41	29.46	11.06	34.03	30.94	11.61	35.73	32.48	12.20

Notes: 1. DB = Dry Bulb Temperature (°C), WB = Wet Bulb Temperature (°C)

2. TGC = Total Gross Cooling Capacity (Unit: kW)

3. SHC = Sensible Heat Capacity (Unit: kW)

4. PI = Power input (kW)

Carrier R410A T1 50Hz Split AC

Gross Cooling Capacity (kW)																			
Outdoor DB(°C)		40.60									46.10								
Indoor	WB(°C)	16.10			19.40			22.80			16.10			19.40			22.80		
CFM	DB(°C)	TGC	SHC	PI	TGC	SHC	PI	TGC	SHC	PI	TGC	SHC	PI	TGC	SHC	PI	TGC	SHC	PI
2470	23.90	17.75	11.83	8.67	18.63	12.42	9.10	19.57	13.04	9.56	17.23	11.49	10.04	18.09	12.06	10.54	19.00	12.66	11.07
	26.70	18.46	14.20	9.02	19.38	14.91	9.47	20.35	15.65	9.94	17.92	13.78	10.44	18.82	14.47	10.96	19.76	15.20	11.51
	29.40	19.20	16.00	9.38	20.15	16.80	9.85	21.16	17.64	10.34	18.64	15.53	10.86	19.57	16.31	11.40	20.55	17.12	11.97
	32.20	19.96	18.15	9.75	20.96	19.06	10.24	22.01	20.01	10.75	19.38	17.62	11.29	20.35	18.50	11.85	21.37	19.43	12.45
2700	23.90	20.76	13.84	10.14	21.80	14.53	10.65	22.89	15.26	11.18	20.16	13.44	11.74	21.16	14.11	12.33	22.22	14.82	12.95
	26.70	21.59	16.61	10.55	22.67	17.44	11.08	23.81	18.31	11.63	20.96	16.13	12.21	22.01	16.93	12.82	23.11	17.78	13.46
	29.40	22.46	18.71	10.97	23.58	19.65	11.52	24.76	20.63	12.10	21.80	18.17	12.70	22.89	19.08	13.33	24.04	20.03	14.00
	32.20	23.35	21.23	11.41	24.52	22.29	11.98	25.75	23.41	12.58	22.67	20.61	13.21	23.81	21.64	13.87	25.00	22.73	14.56
3000	23.90	24.29	16.19	11.87	25.50	17.00	12.46	26.78	17.85	13.08	23.58	15.72	13.74	24.76	16.51	14.42	26.00	17.33	15.14
	26.70	25.26	19.43	12.34	26.52	20.40	12.96	27.85	21.42	13.61	24.52	18.86	14.29	25.75	19.81	15.00	27.04	20.80	15.75
	29.40	26.02	21.68	12.71	27.32	22.77	13.35	28.68	23.90	14.01	25.26	21.05	14.71	26.52	22.10	15.45	27.85	23.21	16.22
	32.20	26.80	24.36	13.09	28.14	25.58	13.75	29.54	26.86	14.43	26.02	23.65	15.16	27.32	24.83	15.91	28.68	26.08	16.71
3300	23.90	27.60	18.40	13.48	28.98	19.32	14.16	30.43	20.29	14.87	26.80	17.87	15.61	28.14	18.76	16.39	29.54	19.70	17.21
	26.70	28.43	21.87	13.89	29.85	22.96	14.58	31.34	24.11	15.31	27.60	21.23	16.08	28.98	22.29	16.88	30.43	23.41	17.73
	29.40	29.28	24.40	14.31	30.75	25.62	15.02	32.28	26.90	15.77	28.43	23.69	16.56	29.85	24.88	17.39	31.34	26.12	18.26
	32.20	30.16	27.42	14.74	31.67	28.79	15.47	33.25	30.23	16.25	29.28	26.62	17.06	30.75	27.95	17.91	32.28	29.35	18.81

- Notes:**
1. DB = Dry Bulb Temperature (°C), WB = Wet Bulb Temperature (°C)
 2. TGC = Total Gross Cooling Capacity (Unit: kW)
 3. SHC = Sensible Heat Capacity (Unit: kW)
 4. PI = Power input (kW)

Gross Cooling Capacity (kW)										
Outdoor DB(°C)		51.70								
Indoor	WB(°C)	16.10			19.40			22.80		
CFM	DB(°C)	TC	SC	PI	TC	SC	PI	TC	SC	PI
2470	23.90	16.73	11.15	16.41	17.23	11.49	16.77	18.44	12.30	17.02
	26.70	17.40	13.38	16.45	17.92	13.78	16.81	19.18	14.75	17.06
	29.40	18.09	15.08	16.49	18.64	15.53	16.85	19.95	16.62	17.10
	32.20	18.82	17.11	16.53	19.38	17.62	16.89	20.75	18.86	17.15
2700	23.90	19.57	13.05	16.61	20.16	13.44	16.97	21.58	14.38	17.22
	26.70	20.35	15.66	16.65	20.96	16.13	17.01	22.44	17.26	17.26
	29.40	21.17	17.64	16.69	21.80	18.17	17.05	23.34	19.45	17.30
	32.20	22.01	20.01	16.73	22.67	20.61	17.10	24.27	22.06	17.35
3000	23.90	22.89	15.26	16.39	23.58	15.72	17.21	25.24	16.83	18.07
	26.70	23.81	18.32	16.43	24.52	18.86	17.25	26.25	20.19	18.11
	29.40	24.52	20.44	16.47	25.26	21.05	17.29	27.04	22.53	18.16
	32.20	25.26	22.96	16.51	26.02	23.65	17.34	27.85	25.32	18.20
3300	23.90	26.02	17.34	17.16	26.80	17.87	17.52	28.68	19.12	17.77
	26.70	26.80	20.61	17.20	27.60	21.23	17.56	29.54	22.73	17.81
	29.40	27.60	23.00	17.24	28.43	23.69	17.60	30.43	25.36	17.85
	32.20	28.43	25.85	17.29	29.28	26.62	17.65	31.34	28.49	17.90

Notes: 1. DB = Dry Bulb Temperature (°C), WB = Wet Bulb Temperature (°C)

2. TGC = Total Gross Cooling Capacity (Unit: kW)

3. SHC = Sensible Heat Capacity (Unit: kW)

4. PI = Power input (kW)

4. PI = Power input (kW)

42LDU-140HN1

Gross Cooling Capacity (kW)																			
Outdoor DB(°C)		29.40									35.00								
Indoor	WB(°C)	16.10			19.40			22.80			16.10			19.40			22.80		
CFM	DB(°C)	TC	SC	PI	TC	SC	PI	TC	SC	PI	TC	SC	PI	TC	SC	PI	TC	SC	PI
3550	23.90	30.97	20.64	9.19	32.20	21.47	9.65	33.48	22.32	10.13	29.78	19.85	10.63	31.27	20.84	11.17	32.83	21.89	11.72
	26.70	32.21	24.77	9.55	33.49	25.76	10.03	34.82	26.79	10.53	30.97	23.82	11.06	32.52	25.01	11.61	34.14	26.26	12.19
	29.40	33.49	27.91	9.94	34.83	29.03	10.43	36.22	30.18	10.95	32.21	26.84	11.50	33.82	28.18	12.08	35.51	29.59	12.68
	32.20	34.83	31.67	10.33	36.22	32.93	10.85	37.67	34.24	11.39	33.49	30.45	11.96	35.17	31.97	12.56	36.93	33.57	13.19
3950	23.90	36.23	24.15	10.75	37.67	25.12	11.28	39.17	26.12	11.85	34.83	23.22	12.44	36.58	24.38	13.06	38.40	25.60	13.72
	26.70	37.68	28.98	11.18	39.18	30.14	11.74	40.74	31.34	12.32	36.23	27.87	12.94	38.04	29.26	13.59	39.94	30.72	14.26
	29.40	39.18	32.65	11.62	40.75	33.96	12.20	42.37	35.31	12.82	37.68	31.40	13.46	39.56	32.97	14.13	41.54	34.62	14.84
	32.20	40.75	37.05	12.09	42.38	38.52	12.69	44.06	40.06	13.33	39.18	35.62	13.99	41.14	37.40	14.69	43.20	39.27	15.43
4400	23.90	42.38	28.25	12.57	44.07	29.38	13.20	45.83	30.55	13.86	40.75	27.17	14.55	42.79	28.53	15.28	44.93	29.95	16.05
	26.70	44.08	33.90	13.08	45.84	35.26	13.73	47.66	36.66	14.42	42.38	32.60	15.14	44.50	34.23	15.89	46.73	35.94	16.69
	29.40	44.96	37.46	13.47	47.21	39.34	14.14	49.09	40.91	14.85	43.65	36.38	15.59	45.84	38.20	16.37	48.13	40.11	17.19
	32.20	46.31	42.10	13.87	48.63	44.21	14.56	50.56	45.97	15.29	44.96	40.87	16.06	47.21	42.92	16.86	49.57	45.06	17.70
4950	23.90	47.70	31.80	14.29	50.09	33.39	15.00	52.08	34.72	15.75	46.31	30.87	16.54	48.63	32.42	17.37	51.06	34.04	18.23
	26.70	49.13	37.79	14.72	51.59	39.68	15.45	53.64	41.26	16.22	47.70	36.69	17.04	50.09	38.53	17.89	52.59	40.45	18.78
	29.40	50.60	42.17	15.16	53.14	44.28	15.92	55.25	46.04	16.71	49.13	40.94	17.55	51.59	42.99	18.42	54.17	45.14	19.35
	32.20	52.12	47.38	15.61	54.73	49.75	16.39	56.91	51.73	17.21	50.61	46.00	18.07	53.14	48.30	18.98	55.79	50.72	19.93

Notes:

1. DB = Dry Bulb Temperature (°C), WB = Wet Bulb Temperature (°C)
2. TC = Total Capacity (kW)
3. SC = Sensible Capacity (kW)
4. PI = Power input (kW)

Gross Cooling Capacity (kW)																			
Outdoor DB(°C)		40.60									46.10								
Indoor	WB(°C)	16.10			19.40			22.80			16.10			19.40			22.80		
CFM	DB(°C)	TC	SC	PI	TC	SC	PI	TC	SC	PI	TC	SC	PI	TC	SC	PI	TC	SC	PI
3550	23.90	26.33	17.55	12.25	27.64	18.43	12.87	29.03	19.35	13.51	25.56	17.04	14.19	26.84	17.89	14.89	28.18	18.79	15.64
	26.70	27.38	21.06	12.74	28.75	22.12	13.38	30.19	23.22	14.05	26.58	20.45	14.75	27.91	21.47	15.49	29.31	22.54	16.27
	29.40	28.48	23.73	13.25	29.90	24.92	13.92	31.39	26.16	14.61	27.65	23.04	15.34	29.03	24.19	16.11	30.48	25.40	16.92
	32.20	29.61	26.92	13.78	31.10	28.27	14.47	32.65	29.68	15.20	28.75	26.14	15.96	30.19	27.45	16.75	31.70	28.82	17.59
3950	23.90	30.80	20.53	14.34	32.34	21.56	15.05	33.96	22.64	15.80	29.90	19.93	16.60	31.40	20.93	17.42	32.97	21.98	18.30
	26.70	32.03	24.64	14.91	33.63	25.87	15.65	35.31	27.17	16.44	31.10	23.92	17.26	32.65	25.12	18.12	34.29	26.37	19.03
	29.40	33.31	27.76	15.51	34.98	29.15	16.28	36.73	30.61	17.09	32.34	26.95	17.95	33.96	28.30	18.85	35.66	29.71	19.79
	32.20	34.65	31.50	16.13	36.38	33.07	16.93	38.20	34.72	17.78	33.64	30.58	18.67	35.32	32.11	19.60	37.08	33.71	20.58
4400	23.90	36.03	24.02	16.77	37.83	25.22	17.61	39.72	26.48	18.49	34.98	23.32	19.41	36.73	24.49	20.38	38.57	25.71	21.40
	26.70	37.47	28.82	17.44	39.35	30.27	18.31	41.31	31.78	19.23	36.38	27.99	20.19	38.20	29.38	21.20	40.11	30.85	22.26
	29.40	38.60	32.16	17.96	40.53	33.77	18.86	42.55	35.46	19.81	37.47	31.23	20.80	39.35	32.79	21.84	41.31	34.43	22.93
	32.20	39.75	36.14	18.50	41.74	37.95	19.43	43.83	39.84	20.40	38.60	35.09	21.42	40.53	36.84	22.49	42.55	38.68	23.62
4950	23.90	40.95	27.30	19.06	42.99	28.66	20.01	45.14	30.10	21.01	39.75	26.50	22.06	41.74	27.83	23.17	43.83	29.22	24.32
	26.70	42.18	32.44	19.63	44.28	34.06	20.61	46.50	35.77	21.64	40.95	31.50	22.72	42.99	33.07	23.86	45.14	34.73	25.05
	29.40	43.44	36.20	20.22	45.61	38.01	21.23	47.89	39.91	22.29	42.18	35.15	23.41	44.28	36.90	24.58	46.50	38.75	25.81
	32.20	44.74	40.68	20.83	46.98	42.71	21.87	49.33	44.85	22.96	43.44	39.49	24.11	45.61	41.47	25.31	47.89	43.54	26.58

Notes:

1. DB = Dry Bulb Temperature (°C), WB = Wet Bulb Temperature (°C)
2. TC = Total Capacity (kW)
3. SC = Sensible Capacity (kW)
4. PI = Power input (kW)

42LDU-170HN1

Gross Cooling Capacity (kW)																			
Outdoor DB(°C)		29.40									35.00								
Indoor	WB(°C)	16.10			19.40			22.80			16.10			19.40			22.80		
CFM	DB(°C)	TC	SC	PI	TC	SC	PI	TC	SC	PI	TC	SC	PI	TC	SC	PI	TC	SC	PI
5100	23.90	38.46	25.64	11.52	40.38	26.92	12.10	42.40	28.27	12.70	37.34	24.89	13.33	39.20	26.14	14.00	41.16	27.44	14.70
	26.70	40.00	30.77	11.98	42.00	32.30	12.58	44.10	33.92	13.21	38.83	29.87	13.87	40.77	31.36	14.56	42.81	32.93	15.29
	29.40	41.60	34.66	12.46	43.68	36.40	13.08	45.86	38.22	13.74	40.38	33.65	14.42	42.40	35.34	15.14	44.52	37.10	15.90
	32.20	43.26	39.33	12.96	45.42	41.29	13.61	47.69	43.36	14.29	42.00	38.18	15.00	44.10	40.09	15.75	46.30	42.10	16.54
5800	23.90	44.99	29.99	13.48	47.24	31.49	14.15	49.60	33.07	14.86	43.68	29.12	15.60	45.86	30.58	16.38	48.16	32.10	17.20
	26.70	46.79	35.99	14.01	49.13	37.79	14.72	51.59	39.68	15.45	45.43	34.94	16.22	47.70	36.69	17.04	50.08	38.53	17.89
	29.40	48.66	40.55	14.58	51.09	42.58	15.30	53.65	44.71	16.07	47.24	39.37	16.87	49.61	41.34	17.72	52.09	43.41	18.60
	32.20	50.61	46.01	15.16	53.14	48.31	15.92	55.79	50.72	16.71	49.13	44.67	17.55	51.59	46.90	18.43	54.17	49.25	19.35
6350	23.90	52.63	35.09	15.76	55.26	36.84	16.55	58.03	38.68	17.38	51.10	34.07	18.25	53.65	35.77	19.16	56.34	37.56	20.12
	26.70	54.74	42.11	16.40	57.47	44.21	17.22	60.35	46.42	18.08	53.14	40.88	18.98	55.80	42.92	19.93	58.59	45.07	20.93
	29.40	56.38	46.98	16.89	59.20	49.33	17.73	62.16	51.80	18.62	54.74	45.61	19.55	57.47	47.90	20.53	60.35	50.29	21.55
	32.20	58.07	52.79	17.39	60.97	55.43	18.26	64.02	58.20	19.18	56.38	51.25	20.14	59.20	53.82	21.14	62.16	56.51	22.20
6800	23.90	59.81	39.88	17.92	62.80	41.87	18.81	65.94	43.96	19.75	58.07	38.71	20.74	60.97	40.65	21.78	64.02	42.68	22.87
	26.70	61.61	47.39	18.45	64.69	49.76	19.38	67.92	52.25	20.34	59.81	46.01	21.36	62.80	48.31	22.43	65.94	50.73	23.55
	29.40	63.46	52.88	19.01	66.63	55.52	19.96	69.96	58.30	20.95	61.61	51.34	22.00	64.69	53.91	23.10	67.92	56.60	24.26
	32.20	65.36	59.42	19.58	68.63	62.39	20.56	72.06	65.51	21.58	63.46	57.69	22.66	66.63	60.57	23.80	69.96	63.60	24.99

Notes:

1. DB = Dry Bulb Temperature (°C), WB = Wet Bulb Temperature (°C)
2. TC = Total Capacity (kW)
3. SC = Sensible Capacity (kW)
4. PI = Power input (kW)

Gross Cooling Capacity (kW)																			
Outdoor DB(°C)		40.60									46.10								
Indoor	WB(°C)	16.10			19.40			22.80			16.10			19.40			22.80		
CFM	DB(°C)	TC	SC	PI	TC	SC	PI	TC	SC	PI	TC	SC	PI	TC	SC	PI	TC	SC	PI
5100	23.90	35.84	23.89	14.74	37.63	25.09	15.48	39.51	26.34	16.25	34.79	23.20	17.06	36.53	24.36	17.92	38.36	25.57	18.81
	26.70	37.27	28.67	15.33	39.14	30.10	16.10	41.09	31.61	16.90	36.19	27.84	17.75	38.00	29.23	18.63	39.90	30.69	19.56
	29.40	38.76	32.30	15.94	40.70	33.92	16.74	42.74	35.61	17.58	37.63	31.36	18.46	39.52	32.93	19.38	41.49	34.58	20.35
	32.20	40.31	36.65	16.58	42.33	38.48	17.41	44.45	40.41	18.28	39.14	35.58	19.19	41.10	37.36	20.15	43.15	39.23	21.16
5800	23.90	41.93	27.95	17.24	44.02	29.35	18.11	46.22	30.82	19.01	40.70	27.14	19.96	42.74	28.49	20.96	44.88	29.92	22.01
	26.70	43.60	33.54	17.93	45.78	35.22	18.83	48.07	36.98	19.77	42.33	32.56	20.76	44.45	34.19	21.80	46.67	35.90	22.89
	29.40	45.35	37.79	18.65	47.61	39.68	19.58	50.00	41.66	20.56	44.03	36.69	21.59	46.23	38.52	22.67	48.54	40.45	23.80
	32.20	47.16	42.87	19.40	49.52	45.02	20.37	52.00	47.27	21.38	45.79	41.63	22.45	48.08	43.71	23.58	50.48	45.89	24.75
6350	23.90	49.05	32.70	20.17	51.50	34.33	21.18	54.08	36.05	22.24	47.62	31.75	23.35	50.00	33.33	24.52	52.50	35.00	25.75
	26.70	51.01	39.24	20.98	53.56	41.20	22.03	56.24	43.26	23.13	49.52	38.10	24.29	52.00	40.00	25.50	54.60	42.00	26.78
	29.40	52.54	43.78	21.61	55.17	45.97	22.69	57.93	48.27	23.82	51.01	42.51	25.01	53.56	44.63	26.27	56.24	46.87	27.58
	32.20	54.12	49.20	22.26	56.82	51.66	23.37	59.66	54.24	24.54	52.54	47.76	25.76	55.17	50.15	27.05	57.93	52.66	28.41
6800	23.90	55.74	37.16	22.92	58.53	39.02	24.07	61.45	40.97	25.27	54.12	36.08	26.54	56.82	37.88	27.86	59.66	39.78	29.26
	26.70	57.41	44.16	23.61	60.28	46.37	24.79	63.30	48.69	26.03	55.74	42.88	27.33	58.53	45.02	28.70	61.45	47.27	30.14
	29.40	59.13	49.28	24.32	62.09	51.74	25.54	65.20	54.33	26.81	57.41	47.84	28.15	60.28	50.24	29.56	63.30	52.75	31.04
	32.20	60.91	55.37	25.05	63.95	58.14	26.30	67.15	61.05	27.62	59.13	53.76	29.00	62.09	56.45	30.45	65.20	59.27	31.97

Notes:

1. DB = Dry Bulb Temperature (°C), WB = Wet Bulb Temperature (°C)
2. TC = Total Capacity (kW)
3. SC = Sensible Capacity (kW)
4. PI = Power input (kW)

8. Static Pressure Curves

42LDU-70HN1

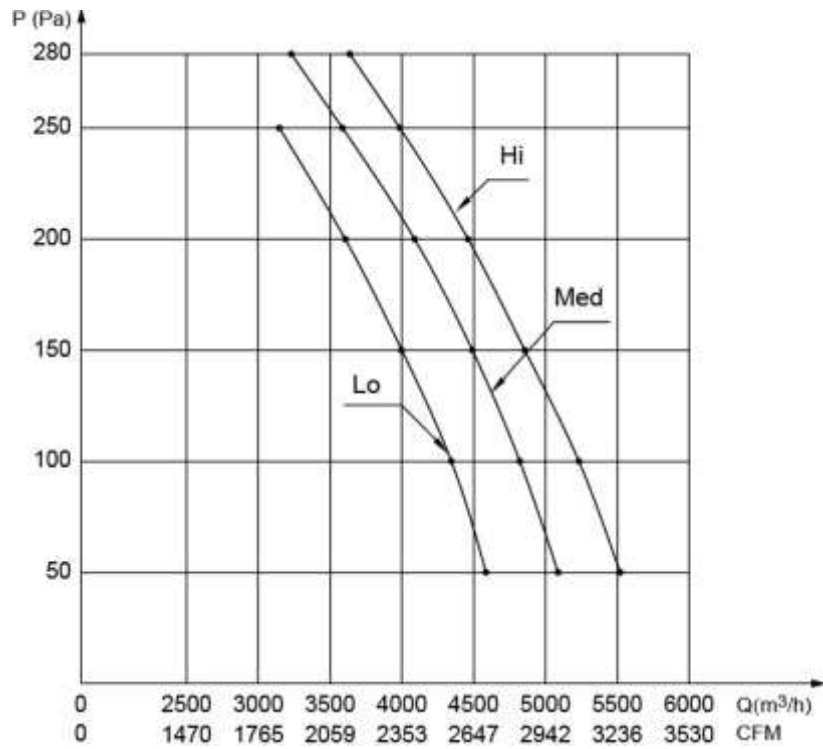

42LDU1-96HN1

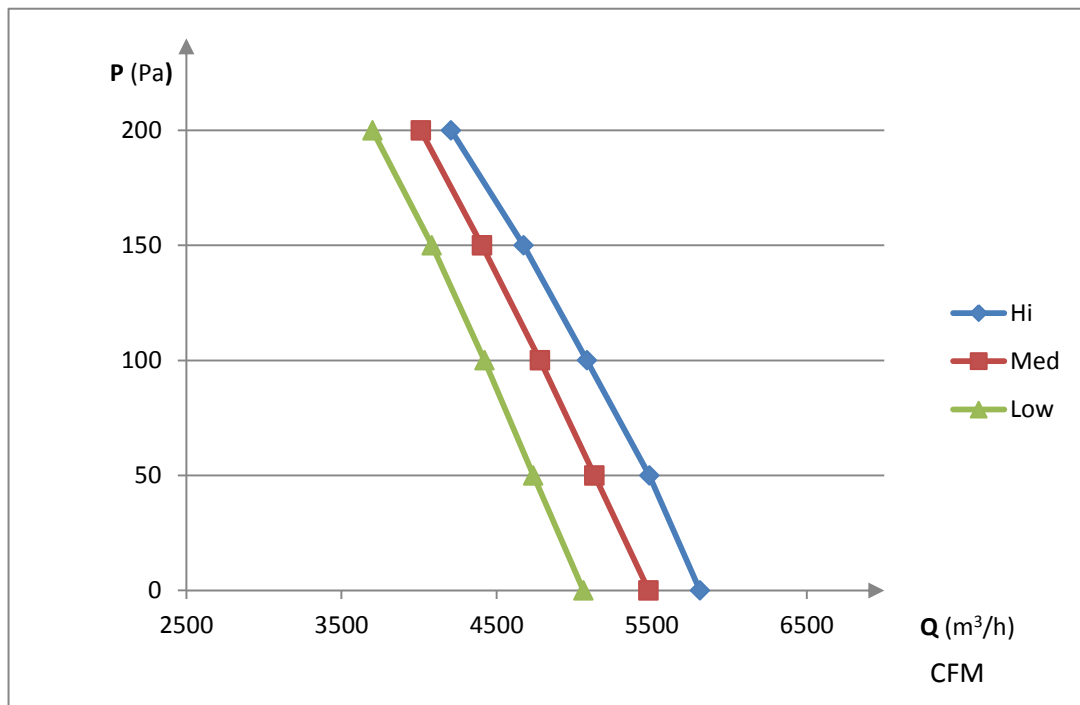

42LDU-140HN1

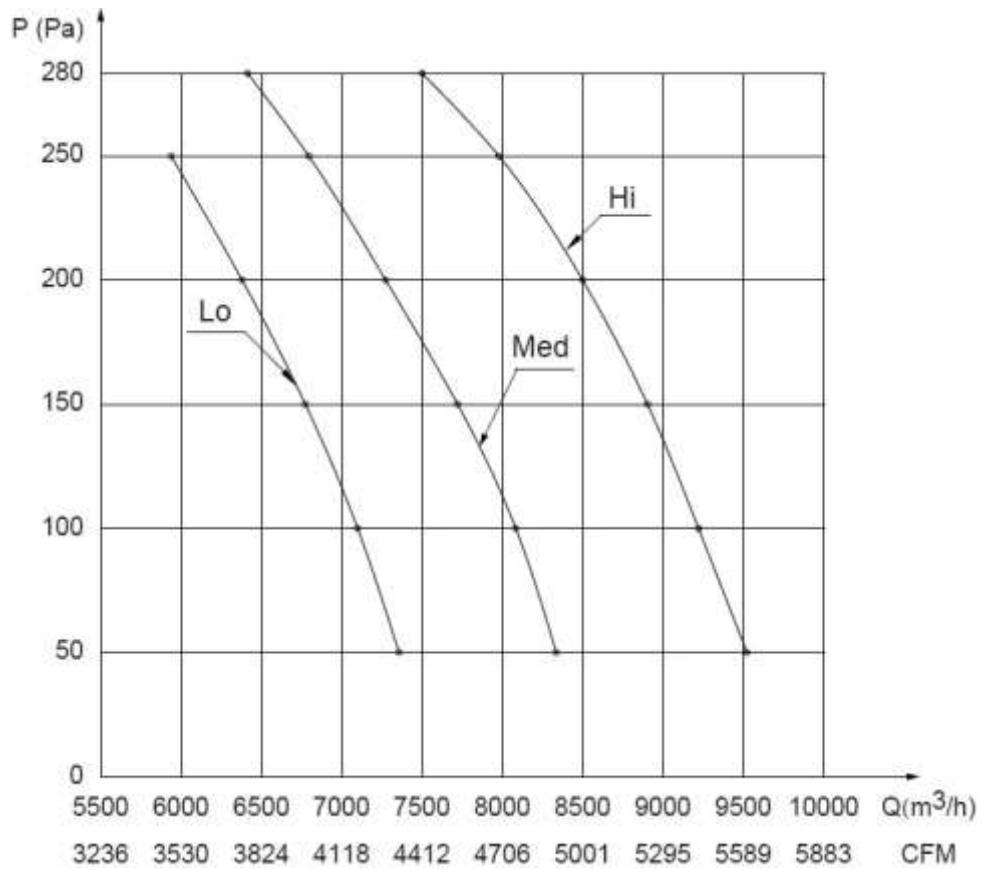

42LDU-170HN1

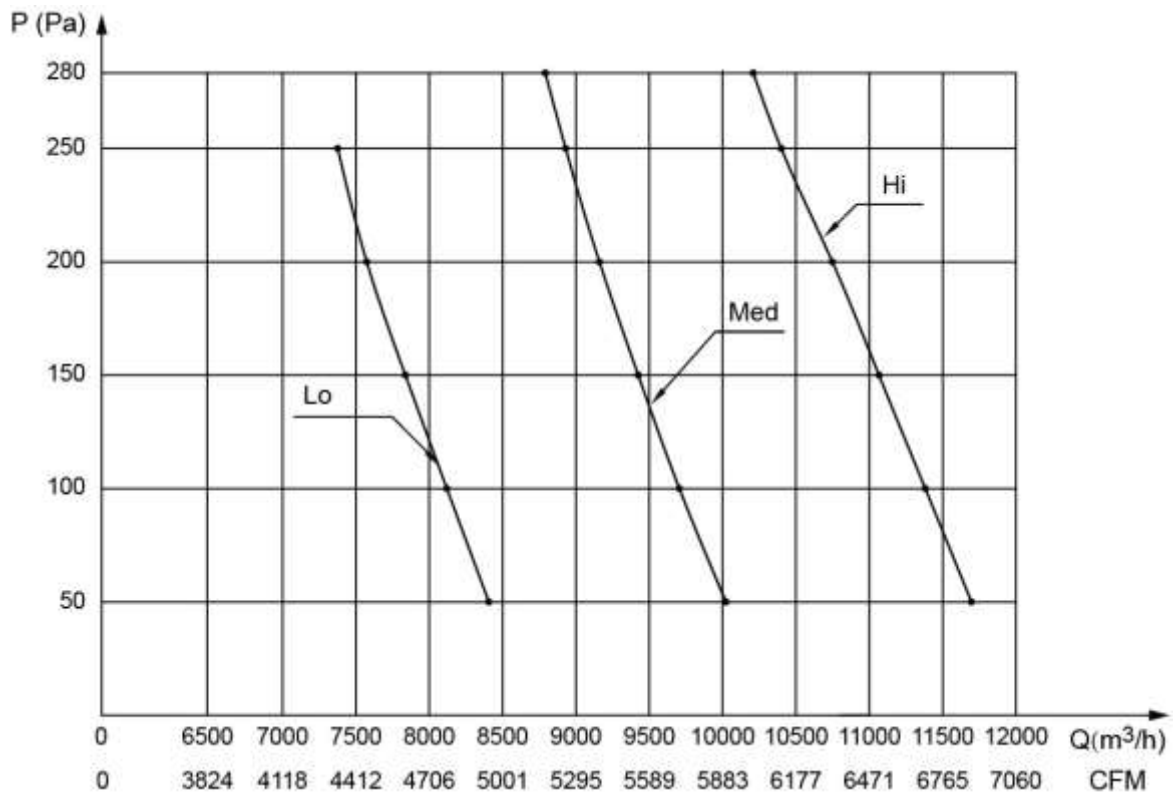

9. Electric Characteristics

Model	Indoor Unit				Power Supply		IFM	
	Hz	Voltage	Min.	Max.	MCA	MFA	kW	FLA
42LDU-70HN1	50	220~240V	198V	264V	8.33	20	0.6	6.66
42LDU1-96HN1	50	220~240V	198V	264V	10	20	1.1	8
42LDU-140HN1	50	220~240V	198V	264V	12.5	20	0.9	10
42LDU-170HN1	50	220~240V	198V	264V	19.7	20	1.8	15.75

Note:

MCA: Min. Current Amps. (A)

MFA: Max. Fuse Amps. (A)

IFM: Indoor Fan Motor

kW: Fan Motor Rated Output (kW)

FLA: Full Load Amps. (A)

10. Sound Levels

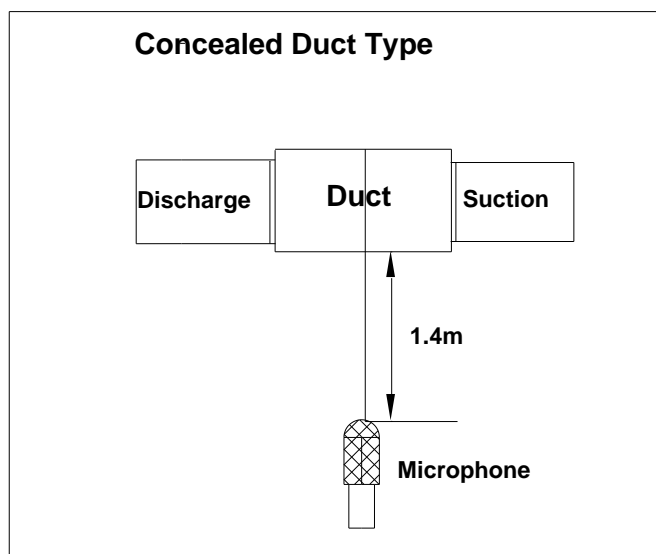

Model	Noise level
42LDU-70HN1	56 dB(A)
42LDU1-96HN1	56 dB(A)
42LDU-140HN1	63 dB(A)
42LDU-170HN1	65 dB(A)

11. Accessories

Name	Qty.	Purpose
Owner's manual	1	—
Installation manual	1	—
Water connective pipe	1	Connect to water drainage pipe
Display board subassembly	1	Connect to control signal
Protective sleeve for refrigerant inlet and outlet pipes	2	—
Wired controller	1	—

Part. 3 Floor-standing Indoor Unit

1. Features	27
2. Specifications	28
3. Dimensions (Unit: mm)	29
4. Service Spaces	30
5. Refrigerant circuits	31
6. Wiring Diagrams	32
7. Capacity Tables	33
8. Electric Characteristics	37
9. Sound Levels	37
10. Accessories	37

1. Features

- ✧ High capacity of cooling and heating, and energy-saving.
- ✧ Thin size, even can installed at limited place.
- ✧ All round steel shell, for high quality protection of transportation.
- ✧ Auto swing louver, wide angle and long distance of air supply.



- ✧ Available for wireless remote control and screen control.
- ✧ Screen 'LOCK' is available.
- ✧ With auto restart function and self-diagnosis function.
- ✧ Easy installation and maintenance.
- ✧ High efficient scroll compressor, with thermal protectors to prevent motor overheating.
- ✧ High performance heat exchanger
- ✧ Direct drive motor. Outdoor unit with axial fan directly drove by motor, and indoor with centrifugal fan directly drove by motor.
- ✧ Washable air inlet filter

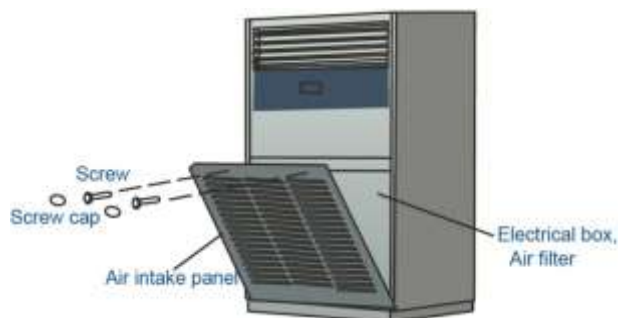

2. Specifications

Model			42CFS-76HN1	42CFS1-96HN1
Power supply		\	220-240V~, 1Ph, 50Hz	220-240V~, 1Ph, 50Hz
Cooling	Capacity	Btu/h	76,000	96,000
		W	22,600	28,100
	Input	W	7,500	9,600
	EER	W/W	3.01	2.93
Heating	Capacity	Btu/h	85,300	106,000
		W	25,000	31,100
	Input	W	7,500	10,300
	COP	W/W	3.33	3.02
Rated input (Indoor unit)		W	700	700
Rated current (Indoor unit)		A	3.0	3.0
Indoor air flow (m ³ /h/CFM)		\	4,300 (2,530)	4,800 (2,824)
Indoor noise level		dB(A)	56	56
Refrigerant type		\	R410A	R410A
Refrigerant control		\	Capillary	Capillary
Fan	Type	\	Centrifugal fan	Centrifugal fan
	Motor model (xQty)	\	YSK300-6 (x1)	YSK300-6 (x1)
	Input (Hi/med/lo)	W	570/510/465	600/500/437
	Capacitor	\	20μF/450V	25μF/450V
	Speed (Hi/med/lo)	r/min	830/750/660	870/760/670
Coil	Type	\	Copper tube and aluminum fin	Copper tube and aluminum fin
	Tube size	mm	Φ7	Φ7
	No. of rows	\	2	3
	Fin spacing	mm	1.5	1.5
	Tube pitchx row pitch	mm	21x13.37	21x13.37
	Lengthx height	mm	982x714	982x714
	Number of circuits	\	17	25
Controller		\	CARR-R51/E	CARR-R51/E
Refrigerant pipe (Liquid/ Gas)		mm	Φ9.52/Φ22	Φ9.52/Φ25.4
Power wire		\	3x2.5mm ²	3x2.5mm ²
Signal wire		\	4x1.0mm ²	4x1.0mm ²
Drain pipe size		mm	Φ41	Φ41
Dimension (WxHxD)		mm	1,200x1,860x518	1,200x1,860x518
Packing (WxHxD)		mm	1,362x2,050x582	1,362x2,050x582
Net/Gross weight		kg	130/145	140/154

Notes:

1. Rated input = Max. input, Rated current = Max. current.

2. Nominal cooling capacities are based on the following conditions:

Indoor temp: 27°CDB, 19°CWB; Outdoor temp: 35°CDB, 24°CWB; Nominal heating capacities are based on the following conditions: Indoor temp: 20°CDB, 15°CWB; Outdoor temp: 7°CDB, 6°CWB.

3. Dimensions (Unit: mm)

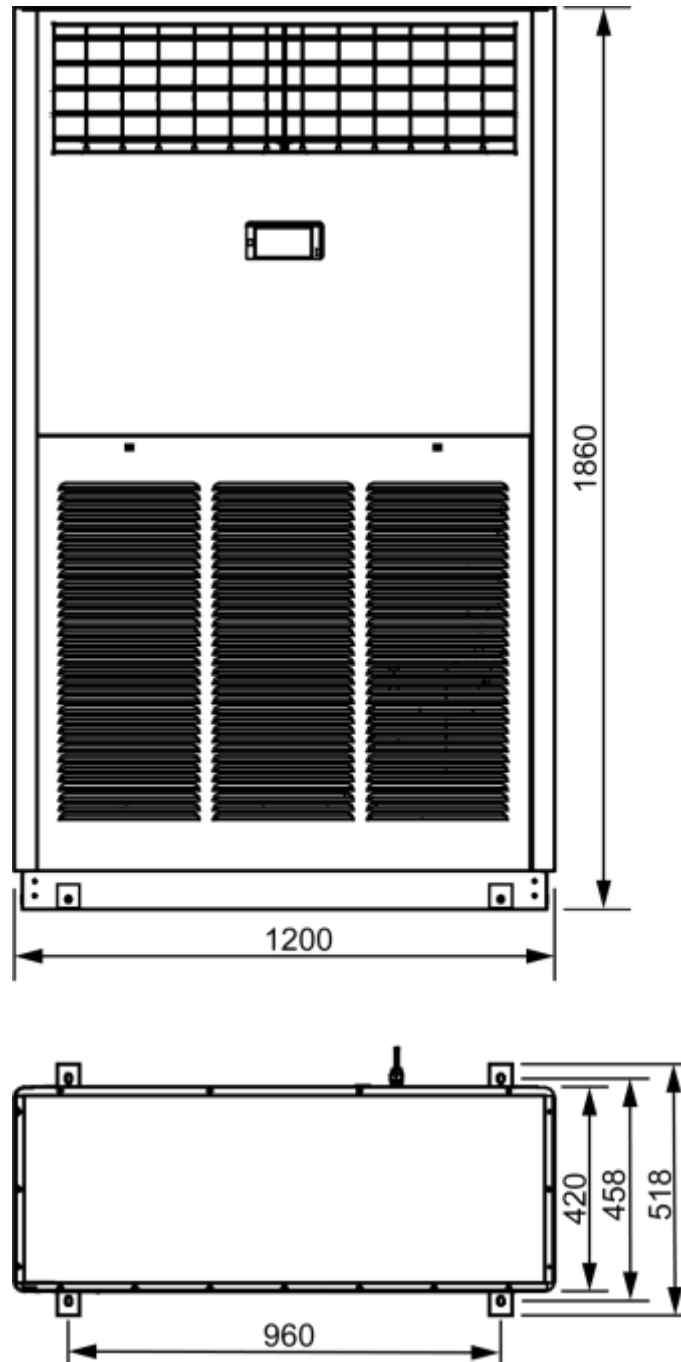

4. Service Spaces

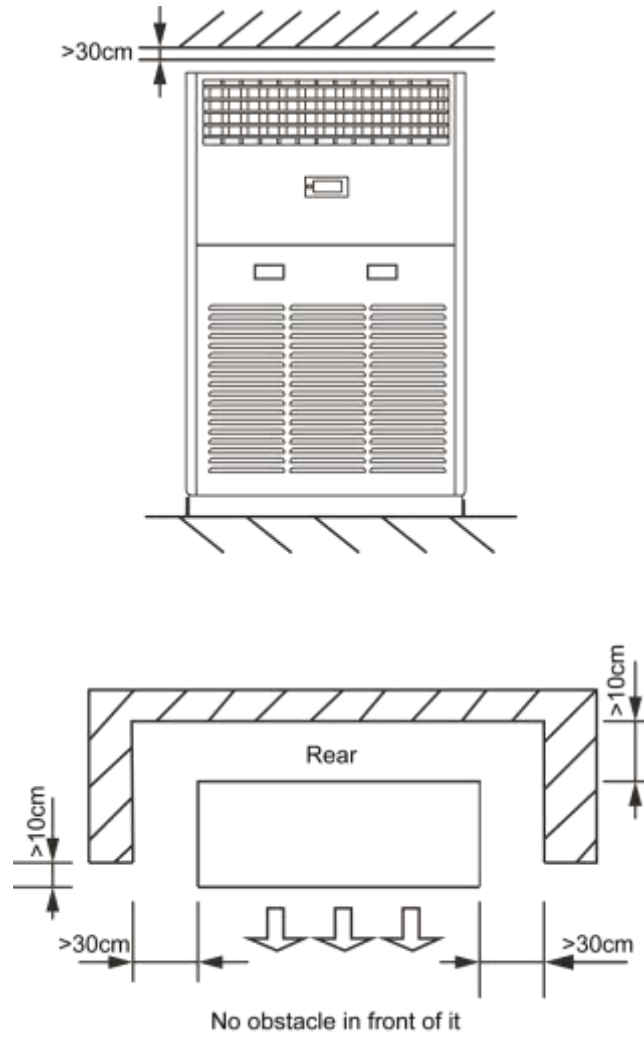

5. Refrigerant circuits

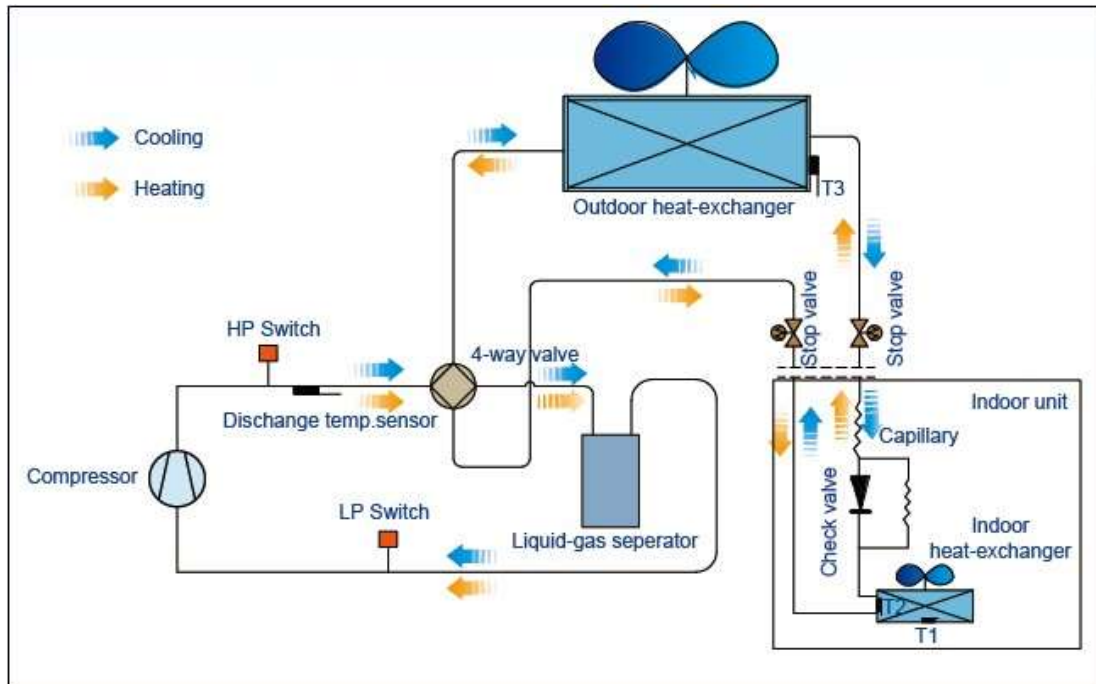

6. Wiring Diagrams

WIRING DIAGRAMING

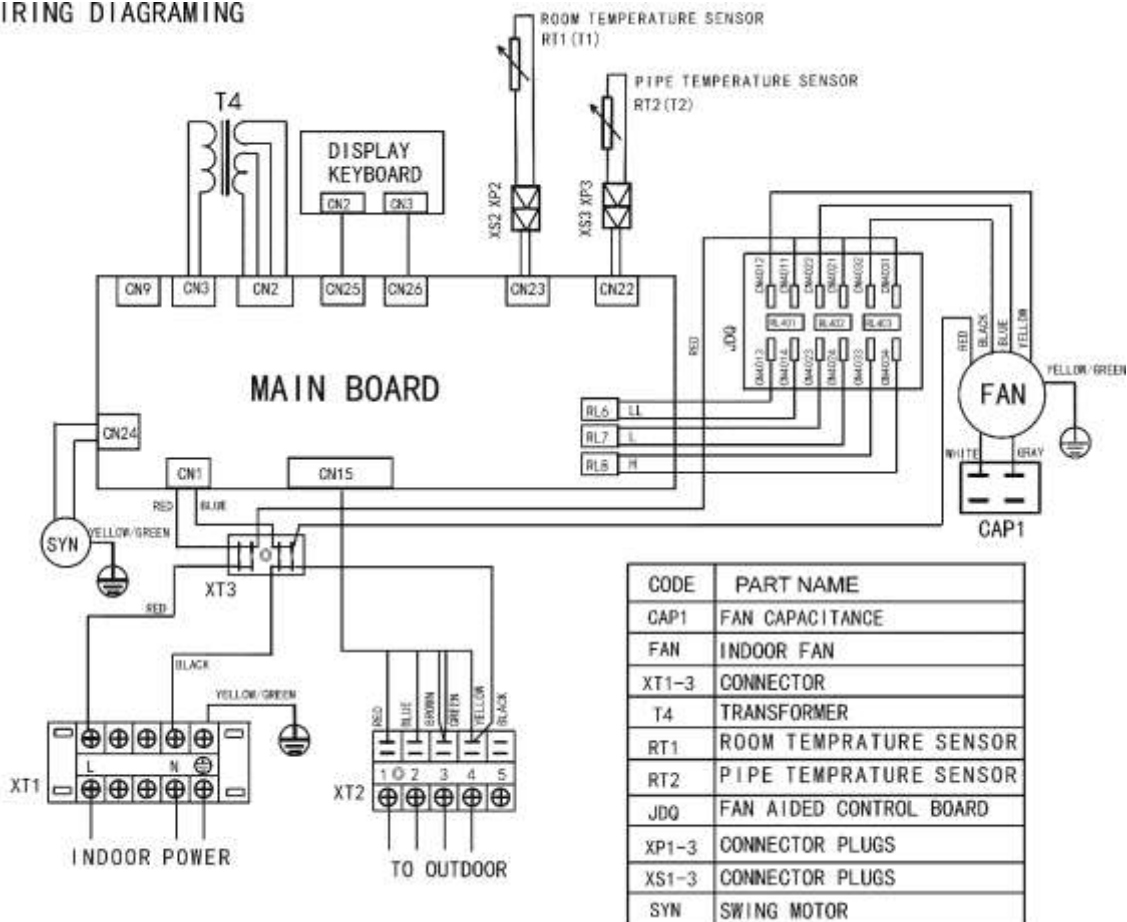

7. Capacity Tables

42CFS-76HN1

Gross Cooling Capacity (kW)																			
Outdoor DB(°C)		29.40									35.00								
Indoor	WB(°C)	16.10			19.40			22.80			16.10			19.40			22.80		
CFM	DB(°C)	TC	SC	PI	TC	SC	PI	TC	SC	PI	TC	SC	PI	TC	SC	PI	TC	SC	PI
2250	23.90	15.60	10.40	4.38	16.38	10.92	4.60	17.20	11.47	4.83	15.14	10.10	5.07	15.90	10.60	5.32	16.70	11.13	5.59
	26.70	16.22	12.48	4.55	17.03	13.10	4.78	17.89	13.76	5.02	15.75	12.12	5.27	16.54	12.72	5.54	17.36	13.36	5.81
	29.40	16.87	14.06	4.74	17.72	14.76	4.97	18.60	15.50	5.22	16.38	13.65	5.48	17.20	14.33	5.76	18.06	15.05	6.05
	32.20	17.55	15.95	4.93	18.42	16.75	5.17	19.35	17.59	5.43	17.04	15.49	5.70	17.89	16.26	5.99	18.78	17.07	6.29
2380	23.90	18.07	12.05	5.12	18.98	12.65	5.38	19.93	13.28	5.65	17.55	11.70	5.93	18.42	12.28	6.23	19.35	12.90	6.54
	26.70	18.80	14.46	5.33	19.74	15.18	5.59	20.72	15.94	5.87	18.25	14.04	6.17	19.16	14.74	6.48	20.12	15.48	6.80
	29.40	19.55	16.29	5.54	20.53	17.10	5.82	21.55	17.96	6.11	18.98	15.82	6.41	19.93	16.61	6.74	20.92	17.44	7.07
	32.20	20.33	18.48	5.76	21.35	19.41	6.05	22.41	20.38	6.35	19.74	17.94	6.67	20.72	18.84	7.01	21.76	19.78	7.36
2500	23.90	20.94	13.96	5.99	21.99	14.66	6.29	23.09	15.39	6.61	20.33	13.55	6.94	21.35	14.23	7.29	22.41	14.94	7.65
	26.70	21.78	16.75	6.23	22.87	17.59	6.55	24.01	18.47	6.87	21.14	16.26	7.22	22.20	17.08	7.58	23.31	17.93	7.96
	29.40	22.43	18.69	6.42	23.55	19.63	6.74	24.73	20.61	7.08	21.78	18.15	7.43	22.87	19.06	7.80	24.01	20.01	8.19
	32.20	23.10	21.00	6.61	24.26	22.05	6.94	25.47	23.16	7.29	22.43	20.39	7.66	23.55	21.41	8.04	24.73	22.48	8.44

Notes:

1. DB = Dry Bulb Temperature (°C), WB = Wet Bulb Temperature (°C)
2. TC = Total Capacity (kW)
3. SC = Sensible Capacity (kW)
4. PI = Power input (kW)

Carrier R410A T1 50Hz Split AC

Gross Cooling Capacity (kW)																			
Outdoor DB(°C)		40.60									46.10								
Indoor	WB(°C)	16.10			19.40			22.80			16.10			19.40			22.80		
CFM	DB(°C)	TC	SC	PI	TC	SC	PI	TC	SC	PI	TC	SC	PI	TC	SC	PI	TC	SC	PI
2250	23.90	13.84	9.23	6.59	14.53	9.69	6.92	15.26	10.17	7.26	13.44	8.96	7.63	14.11	9.41	8.01	14.82	9.88	8.41
	26.70	14.40	11.07	6.85	15.12	11.63	7.20	15.87	12.21	7.56	13.98	10.75	7.93	14.68	11.29	8.33	15.41	11.85	8.75
	29.40	14.97	12.48	7.13	15.72	13.10	7.48	16.51	13.76	7.86	14.54	12.11	8.25	15.26	12.72	8.66	16.03	13.35	9.10
	32.20	15.57	14.16	7.41	16.35	14.86	7.78	17.17	15.61	8.17	15.12	13.74	8.58	15.87	14.43	9.01	16.67	15.15	9.46
2380	23.90	16.04	10.69	7.71	16.84	11.23	8.09	17.68	11.79	8.50	15.57	10.38	8.92	16.35	10.90	9.37	17.17	11.44	9.84
	26.70	16.68	12.83	8.02	17.51	13.47	8.42	18.39	14.15	8.84	16.19	12.46	9.28	17.00	13.08	9.74	17.85	13.73	10.23
	29.40	17.35	14.46	8.34	18.21	15.18	8.75	19.12	15.94	9.19	16.84	14.03	9.65	17.68	14.74	10.13	18.57	15.47	10.64
	32.20	18.04	16.40	8.67	18.94	17.22	9.10	19.89	18.08	9.56	17.51	15.92	10.04	18.39	16.72	10.54	19.31	17.55	11.07
2500	23.90	18.58	12.39	9.02	19.51	13.01	9.47	20.49	13.66	9.94	18.04	12.03	10.44	18.94	12.63	10.96	19.89	13.26	11.51
	26.70	19.32	14.87	9.38	20.29	15.61	9.85	21.31	16.39	10.34	18.76	14.43	10.86	19.70	15.15	11.40	20.69	15.91	11.97
	29.40	19.90	16.59	9.66	20.90	17.42	10.14	21.94	18.29	10.65	19.32	16.10	11.18	20.29	16.91	11.74	21.31	17.75	12.33
	32.20	20.50	18.64	9.95	21.53	19.57	10.45	22.60	20.55	10.97	19.90	18.10	11.52	20.90	19.00	12.33	21.94	19.95	12.70

Notes:

1. DB = Dry Bulb Temperature (°C), WB = Wet Bulb Temperature (°C)
2. TC = Total Capacity (kW)
3. SC = Sensible Capacity (kW)
4. PI = Power input (kW)

42CFS1-96HN1

Gross Cooling Capacity (kW)																			
Outdoor DB(°C)		29.40									35.00								
Indoor	WB(°C)	16.10			19.40			22.80			16.10			19.40			22.80		
CFM	DB(°C)	TGC	SHC	PI	TGC	SHC	PI	TGC	SHC	PI	TGC	SHC	PI	TGC	SHC	PI	TGC	SHC	PI
2300	23.90	19.46	12.97	5.62	20.43	13.62	5.90	21.45	14.30	6.20	18.89	12.59	6.51	19.83	13.22	6.83	20.82	13.88	7.18
	26.70	20.23	15.56	5.85	21.25	16.34	6.14	22.31	17.16	6.45	19.64	15.11	6.77	20.63	15.87	7.11	21.66	16.66	7.46
	29.40	21.04	17.54	6.08	22.09	18.41	6.39	23.20	19.33	6.70	20.43	17.02	7.04	21.45	17.88	7.39	22.52	18.77	7.76
	32.20	21.88	19.90	6.32	22.98	20.89	6.64	24.13	21.93	6.97	21.25	19.32	7.32	22.31	20.28	7.69	23.42	21.30	8.07
2630	23.90	22.76	15.17	6.58	23.90	15.93	6.91	25.09	16.73	7.25	22.10	14.73	7.61	23.20	15.47	7.99	24.36	16.24	8.39
	26.70	23.67	18.21	6.84	24.85	19.12	7.18	26.10	20.07	7.54	22.98	17.68	7.92	24.13	18.56	8.31	25.34	19.49	8.73
	29.40	24.62	20.51	7.11	25.85	21.54	7.47	27.14	22.62	7.84	23.90	19.92	8.24	25.10	20.91	8.65	26.35	21.96	9.08
	32.20	25.60	23.27	7.40	26.88	24.44	7.77	28.23	25.66	8.16	24.86	22.60	8.56	26.10	23.73	8.99	27.40	24.91	9.44
3000	23.90	26.63	17.75	7.69	27.96	18.64	8.08	29.36	19.57	8.48	25.85	17.23	8.91	27.14	18.10	9.35	28.50	19.00	9.82
	26.70	27.96	21.51	8.00	29.36	22.58	8.40	30.82	23.71	8.82	27.14	20.88	9.26	28.50	21.92	9.73	29.93	23.02	10.21
	29.40	28.80	24.00	8.24	30.24	25.20	8.65	31.75	26.46	9.09	27.96	23.30	9.54	29.36	24.46	10.02	30.82	25.69	10.52
	32.20	29.66	26.96	8.49	31.14	28.31	8.91	32.70	29.73	9.36	28.80	26.18	9.83	30.24	27.49	10.32	31.75	28.86	10.84

Notes: 1. DB = Dry Bulb Temperature (°C), WB = Wet Bulb Temperature (°C)

2. TGC = Total Gross Cooling Capacity (Unit: kW)

3. SHC = Sensible Heat Capacity (Unit: kW)

4. PI = Power input (kW)

Carrier R410A T1 50Hz Split AC

Gross Cooling Capacity (kW)																			
Outdoor DB(°C)		40.60									46.10								
Indoor	WB(°C)	16.10			19.40			22.80			16.10			19.40			22.80		
CFM	DB(°C)	TGC	SHC	PI	TGC	SHC	PI	TGC	SHC	PI	TGC	SHC	PI	TGC	SHC	PI	TGC	SHC	PI
2300	23.90	17.58	11.72	8.67	18.46	12.30	9.10	19.38	12.92	9.56	17.07	11.38	10.04	17.92	11.95	10.54	18.82	12.54	11.07
	26.70	18.28	14.06	9.02	19.20	14.77	9.47	20.15	15.50	9.94	17.75	13.65	10.44	18.64	14.34	10.96	19.57	15.05	11.51
	29.40	19.01	15.84	9.38	19.96	16.64	9.85	20.96	17.47	10.34	18.46	15.38	10.86	19.38	16.15	11.40	20.35	16.96	11.97
	32.20	19.77	17.98	9.75	20.76	18.87	10.24	21.80	19.82	10.75	19.20	17.45	11.29	20.16	18.32	11.85	21.16	19.24	12.45
2630	23.90	20.56	13.71	10.14	21.59	14.39	10.65	22.67	15.11	11.18	19.96	13.31	11.74	20.96	13.98	12.33	22.01	14.67	12.95
	26.70	21.39	16.45	10.55	22.46	17.27	11.08	23.58	18.14	11.63	20.76	15.97	12.21	21.80	16.77	12.82	22.89	17.61	13.46
	29.40	22.24	18.53	10.97	23.35	19.46	11.52	24.52	20.43	12.10	21.59	17.99	12.70	22.67	18.89	13.33	23.81	19.84	14.00
	32.20	23.13	21.03	11.41	24.29	22.08	11.98	25.50	23.18	12.58	22.46	20.42	13.21	23.58	21.44	13.87	24.76	22.51	14.56
3000	23.90	24.29	16.19	11.87	25.50	17.00	12.46	26.78	17.85	13.08	23.58	15.72	13.74	24.76	16.51	14.42	26.00	17.33	15.14
	26.70	25.26	19.43	12.34	26.52	20.40	12.96	27.85	21.42	13.61	24.52	18.86	14.29	25.75	19.81	15.00	27.04	20.80	15.75
	29.40	26.02	21.68	12.71	27.32	22.77	13.35	28.68	23.90	14.01	25.26	21.05	14.71	26.52	22.10	15.45	27.85	23.21	16.22
	32.20	26.80	24.36	13.09	28.14	25.58	13.75	29.54	26.86	14.43	26.02	23.65	15.16	27.32	24.83	15.91	28.68	26.08	16.71

Notes: 1. DB = Dry Bulb Temperature (°C), WB = Wet Bulb Temperature (°C)

2. TGC = Total Gross Cooling Capacity (Unit: kW)

3. SHC = Sensible Heat Capacity (Unit: kW)

4. PI = Power input (kW)

Gross Cooling Capacity (kW)										
Outdoor DB(°C)		51.70								
Indoor	WB(°C)	16.10			19.40			22.80		
CFM	DB(°C)	TGC	SHC	PI	TGC	SHC	PI	TGC	SHC	PI
2300	23.90	16.73	11.15	16.41	17.23	11.49	16.77	18.44	12.30	17.02
	26.70	17.40	13.38	16.45	17.92	13.78	16.81	19.18	14.75	17.06
	29.40	18.09	15.08	16.49	18.64	15.53	16.85	19.95	16.62	17.10
	32.20	18.82	17.11	16.53	19.38	17.62	16.89	20.75	18.86	17.15
2630	23.90	19.57	13.05	16.61	20.16	13.44	16.97	21.58	14.38	17.22
	26.70	20.35	15.66	16.65	20.96	16.13	17.01	22.44	17.26	17.26
	29.40	21.17	17.64	16.69	21.80	18.17	17.05	23.34	19.45	17.30
	32.20	22.01	20.01	16.73	22.67	20.61	17.10	24.27	22.06	17.35
3000	23.90	22.89	15.26	16.39	23.58	15.72	17.21	25.24	16.83	18.07
	26.70	23.81	18.32	16.43	24.52	18.86	17.25	26.25	20.19	18.11
	29.40	24.52	20.44	16.47	25.26	21.05	17.29	27.04	22.53	18.16
	32.20	25.26	22.96	16.51	26.02	23.65	17.34	27.85	25.32	18.20

Notes: 1. DB = Dry Bulb Temperature (°C), WB = Wet Bulb Temperature (°C)

2. TGC = Total Gross Cooling Capacity (Unit: kW)

3. SHC = Sensible Heat Capacity (Unit: kW)

4. PI = Power input (kW)

8. Electric Characteristics

Model	Indoor Unit				Power Supply		IFM	
	Hz	Voltage	Min.	Max.	MCA	MFA	kW	FLA
42CFS-76HN1	50	220~240V	198V	264V	3.55	20	0.3	2.84
42CFS1-96HN1	50	220~240V	198V	264V	3.55	20	0.3	2.84

Note:

MCA: Min. Current Amps. (A)

MFA: Max. Fuse Amps. (A)

IFM: Indoor Fan Motor



kW: Fan Motor Rated Output (kW)

FLA: Full Load Amps. (A)

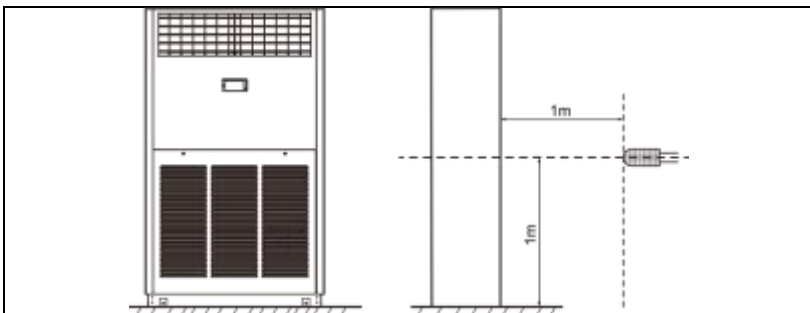
9. Sound Levels

	Model	Noise level
	42CFS-76HN1	56 dB(A)
	42CFS1-96HN1	56 dB(A)

10. Accessories

Name	Qty.	Shape	Usage
Owner's manual	1	—	—
Installation manual	1	—	—
Remote controller manual	1	—	—
Water connective pipe	1	—	Connect to water drainage pipe
Remote controller	1		—
AAA battery	2		—

Part. 4 Outdoor Unit

1. Specifications.....	39
2. Dimensions (Unit: mm)	42
3. Service Spaces.....	44
4. Wiring Diagrams	45
5. Electric Characteristics	48
6. Sound Levels.....	48

1. Specifications

Model		38LDU-70HN1	38LDU-76HN1
Power supply	\	380-415V~, 3Ph, 50Hz	380-415V~, 3Ph, 50Hz
Ambient temp in cooling	°C	17~46	17~46
Ambient temp in heating	°C	-7~24	-7~24
Rated input (Outdoor unit)	W	11,700	11,700
Rated current (Outdoor unit)	A	19.3	19.3
Noise level	dB(A)	68	68
Compressor	Type xQty.	\	Scroll x1
	Brand	\	Copeland
	Model	\	ZP90KCE-TFD-522
	Capacity	W	21,900
	Input	W	6,950
	Rated current	A	16.5
	Locked rotor Amp	A	95
	Refrigerant oil	ml	2,513 (POE)
Refrigerant type/charge	\	R410A/5,400g	R410A/5,400g
Fan	Type xQty.	\	Axial fan x2
	Motor model	\	YDK210-6A
	Motor input (4/3 fan blades)	\	Hi: 284; Lo: 202
	Capacitor	\	10µF/450V
	Motor speed (4/3 fan blades)	rpm	Hi: 920/930; Lo: 650/710
Coil	Type	\	Copper tube and aluminum fin
	Tube size	mm	Φ7
	No. of rows	\	2
	Fin space	mm	1.3
	Tube pitch(a)xrow pitch(b)	mm	21x13.37
	Coil (WxH)	mm	2,175x882
	Number of circuits	\	18
Refrigerant pipe	Liquid side/ Gas side	mm	Φ9.52/Φ22
	Max. pipe length	m	50
	Max. difference in level	\	25m(O.D. up) /30m(O.D. down)
Connection wire	Power wire	\	5x6.0mm ²
	Signal wire	\	4x1.0mm ²
Dimension (WxHxD)	mm	1,260x908x700	1,260x908x700
Packing (WxHxD)	mm	1,320x1,060x730	1,320x1,060x730
Net/ Gross weight	kg	174/193	174/193

Notes:

1. Rated input = Max. input, Rated current = Max. current.

2. Nominal cooling capacities are based on the following conditions: Indoor temp: 27°CDB, 19°CWB; Outdoor temp: 35°CDB; Nominal heating capacities are based on the following conditions: Indoor temp: 20°CDB; Outdoor temp: 7°CDB, 6°CWB.

Model			38LDU1-96HN1	38LDU-140HN1
Power supply		\	380-415V~, 3Ph, 50Hz	380-415V~, 3Ph, 50Hz
Ambient temp in cooling		°C	17~46	17~46
Ambient temp in heating		°C	-7~24	-7~24
Rated input (Outdoor unit)		W	14,400	26,900
Rated current (Outdoor unit)		A	23.7	47.9
Noise level		dB(A)	68	70
Compressor	Type xQty.	\	Scroll x1	Scroll x3
	Brand	\	Danfoss	Hitachi
	Model	\	H CJ121T4LC6	E605DH-59D2YG
	Capacity	W	29,717	15,390
	Input	W	9,200	5,130
	Rated current	A	17.9	8.8
	Locked rotor Amp	A	125	62
	Refrigerant oil	ml	2,460	500 (FVC68D)
Refrigerant type/charge		\	R410A/6,000g	R410A/10,000g
Fan	Type xQty.	\	Axial fan x2	Axial fan x2
	Motor model	\	YDK400-4C	YDK380-4D
	Motor input (4/3 fan blades)	\	Hi: 612/587; Lo: 388	Hi: 615/580; Lo: 425/420
	Capacitor	\	25µF/450V	20µF/450V
	Motor speed (4/3 fan blades)	rpm	Hi: 1,180/1,230; Lo: 790/870	Hi: 1000/1090; Lo: 780/870
Coil	Type	\	Copper tube and aluminum fin	Copper tube and aluminum fin
	Tube size	mm	Φ7	Φ7.94
	No. of rows	\	3	2
	Fin space	mm	1.3	1.6
	Tube pitch(a)xrow pitch(b)	mm	22x19	22x19.05
	Coil (WxH)	mm	2,177x880	2,286x1,232
	Number of circuits	\	20	28
Refrigerant pipe	Liquid side/ Gas side	mm	Φ9.52/Φ25.4	Φ16/Φ32
	Max. pipe length	m	50	50
	Max. difference in level	\	25m(O.D. up) /30m(O.D. down)	
Connection wire	Power wire	\	4x10.0mm ²	5x16.0mm ²
	Signal wire	\	5x0.5mm ²	4x1.0mm ²
Dimension (WxHxD)		mm	1,312x919x658	1,250x1,615x765
Packing (WxHxD)		mm	1,320x1,060x730	1,305x1,790x820
Net/ Gross weight		kg	17/192	288/308

Notes:

1. Rated input = Max. input, Rated current = Max. current.

2. Nominal cooling capacities are based on the following conditions: Indoor temp: 27°CDB, 19°CWB; Outdoor temp: 35°CDB; Nominal heating capacities are based on the following conditions: Indoor temp: 20°CDB; Outdoor temp: 7°CDB, 6°CWB.

Carrier R410A T1 50Hz Split AC

Model		38LDU-170HN1		
Power supply	\	380-415V~, 3Ph, 50Hz		
Ambient temp in cooling	°C	17~46		
Ambient temp in heating	°C	-7~24		
Rated input (Outdoor unit)	W	32,200		
Rated current (Outdoor unit)	A	53.8		
Noise level	dB(A)	73		
Compressor	Type xQty.	\	Scroll x3	
	Brand	\	Hitachi	
	Model	\	E655DH-65D2YG(GC)	
	Capacity	W	17,100	
	Input	W	5,700	
	Rated current	A	9.6	
	Locked rotor Amp	A	64	
	Refrigerant oil	ml	500 (FVC68D)	
Refrigerant type/charge	\	R410A/11,800g		
Fan	Type xQty.	\	Axial fan x2	
	Motor model	\	YDK380-4D	YDK450-6C
	Motor input (4/3 fan blades)	\	580/420	724/399
	Capacitor	\	20µF/450V	25µF/450V
	Motor speed (4/3 fan blades)	rpm	Hi:1,090/Med:870(3 blades)	Hi:840/Med:550(4 blades)
Coil	Type	\	Copper tube and aluminum fin	
	Tube size	mm	Φ7.94	
	No. of rows	\	2	
	Fin space	mm	1.6	
	Tube pitch(a)xrow pitch(b)	mm	22x19.05	
	Coil (WxH)	mm	3,155x1,232	
	Number of circuits	\	28	
Refrigerant pipe	Liquid side/ Gas side	mm	Φ16/Φ32	
	Max. pipe length	m	50	
	Max. difference in level	\	25m(O.D. up) /30m(O.D. down)	
Connection wire	Power wire	\	5x16.0mm ²	
	Signal wire	\	4x1.0mm ²	
Dimension (WxHxD)	mm	1,390x1,615x765		
Packing (WxHxD)	mm	1,455x1,790x830		
Net/ Gross weight	kg	320/336		

Notes:

1. Rated input = Max. input, Rated current = Max. current.

2. Nominal cooling capacities are based on the following conditions: Indoor temp: 27°CDB, 19°CWB; Outdoor temp: 35°CDB; Nominal heating capacities are based on the following conditions: Indoor temp: 20°CDB; Outdoor temp: 7°CDB, 6°CWB.

2. Dimensions (Unit: mm)

38LDU-070HN1, 38LDU-076HN1



Top view

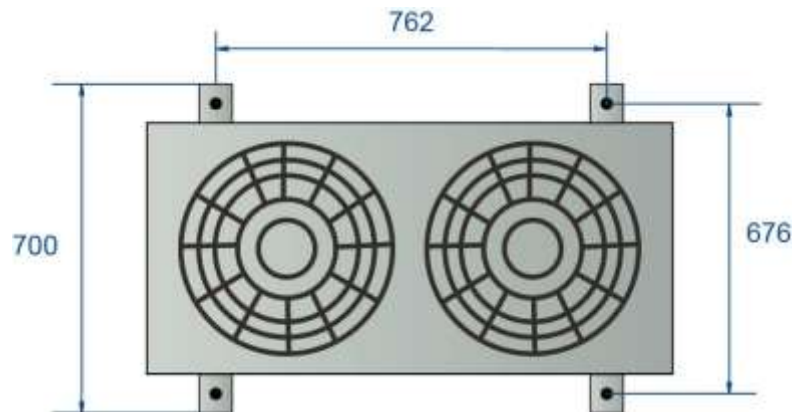

38LDU1-96HN1

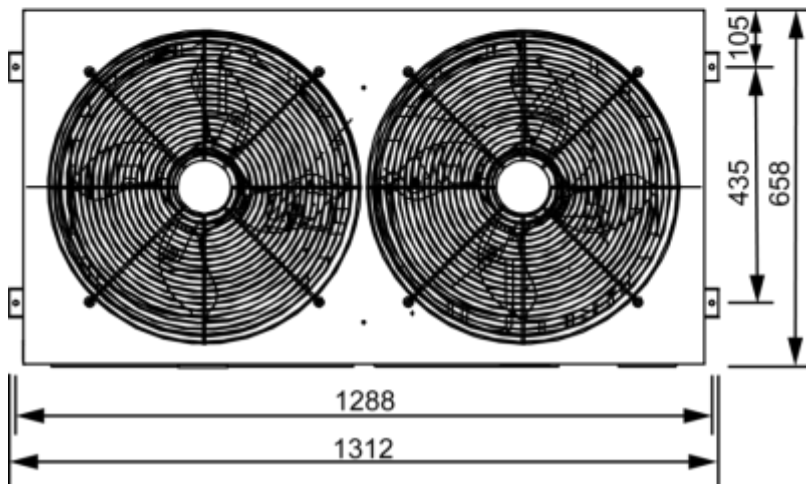
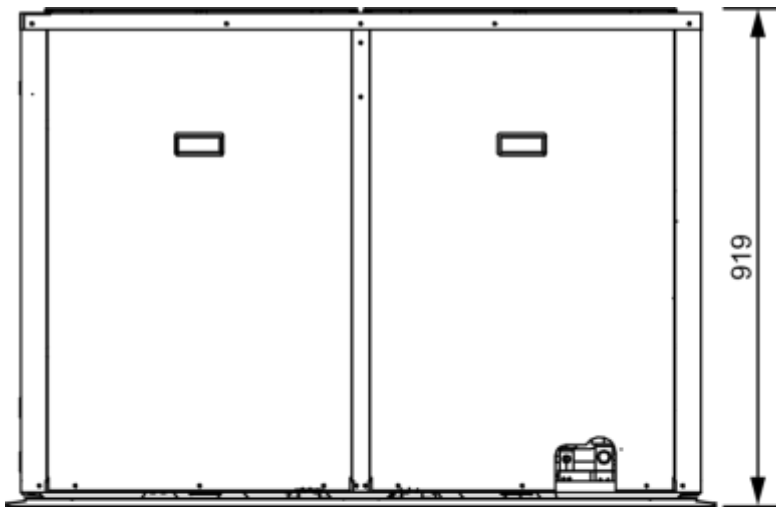

38LDU1-140HN1

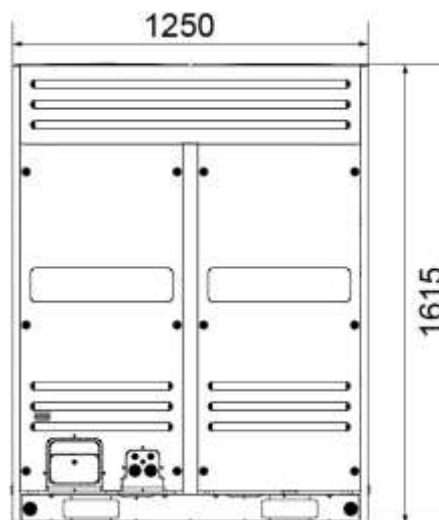

Top view

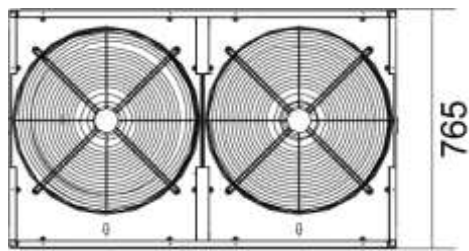

38LDU-170HN1

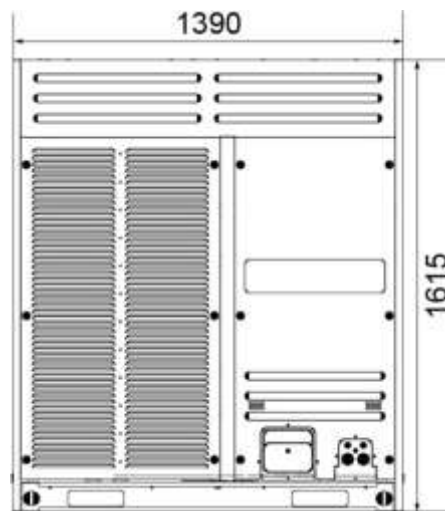

Top view

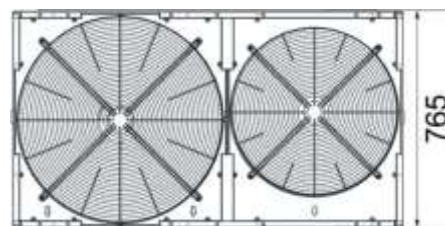

3. Service Spaces

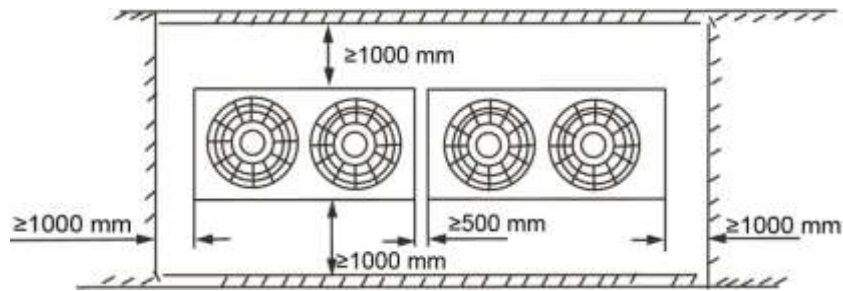

Notes:

1. In case any obstacles exist above the outdoor unit, such obstacles must be 2000mm above the outdoor unit.
2. If miscellaneous articles are piled around the outdoor unit, such articles must be 400mm below the top of the outdoor unit.

4. Wiring Diagrams

38LDU-070HN1, 38LDU-076HN1

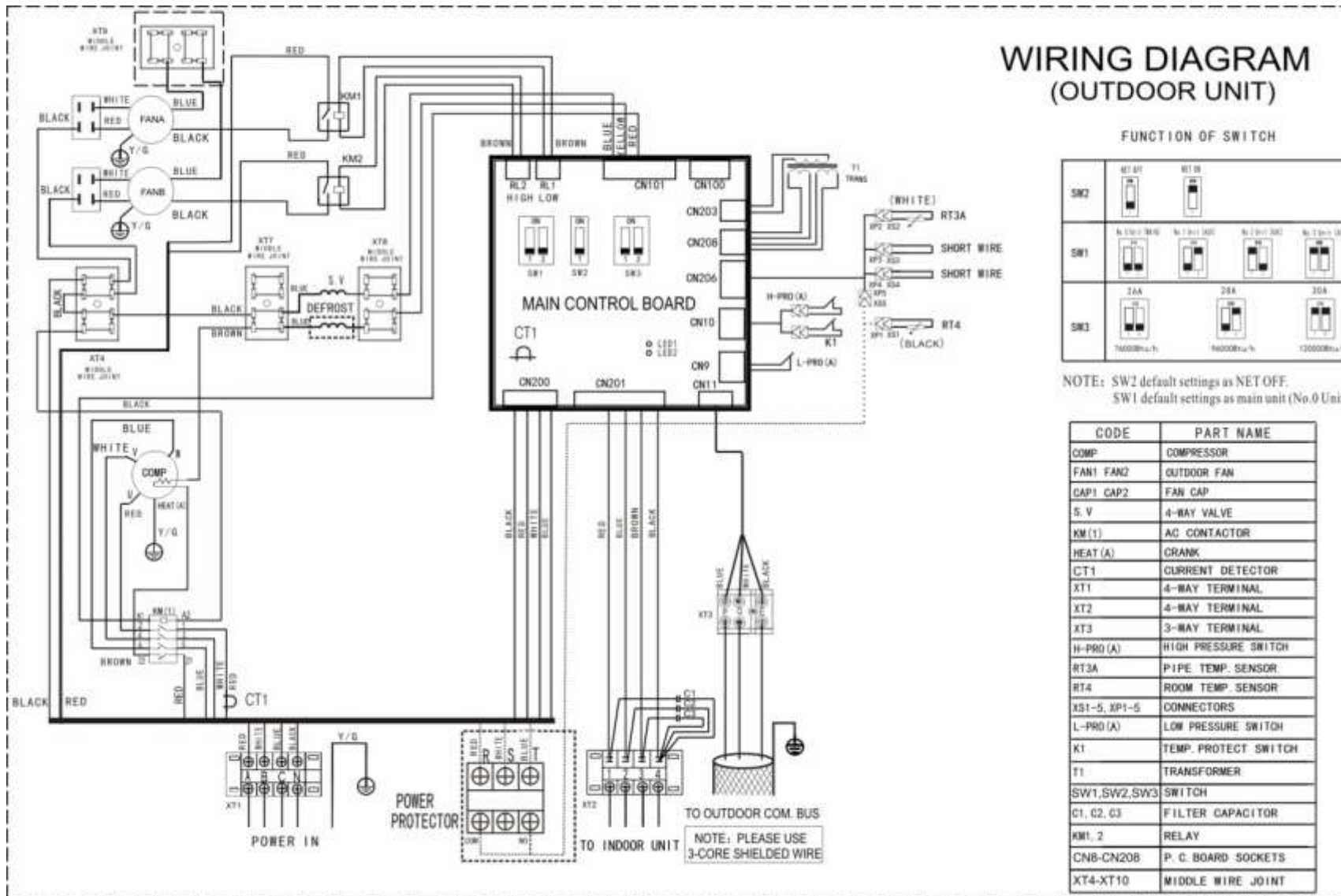

38LDU1-96HN1

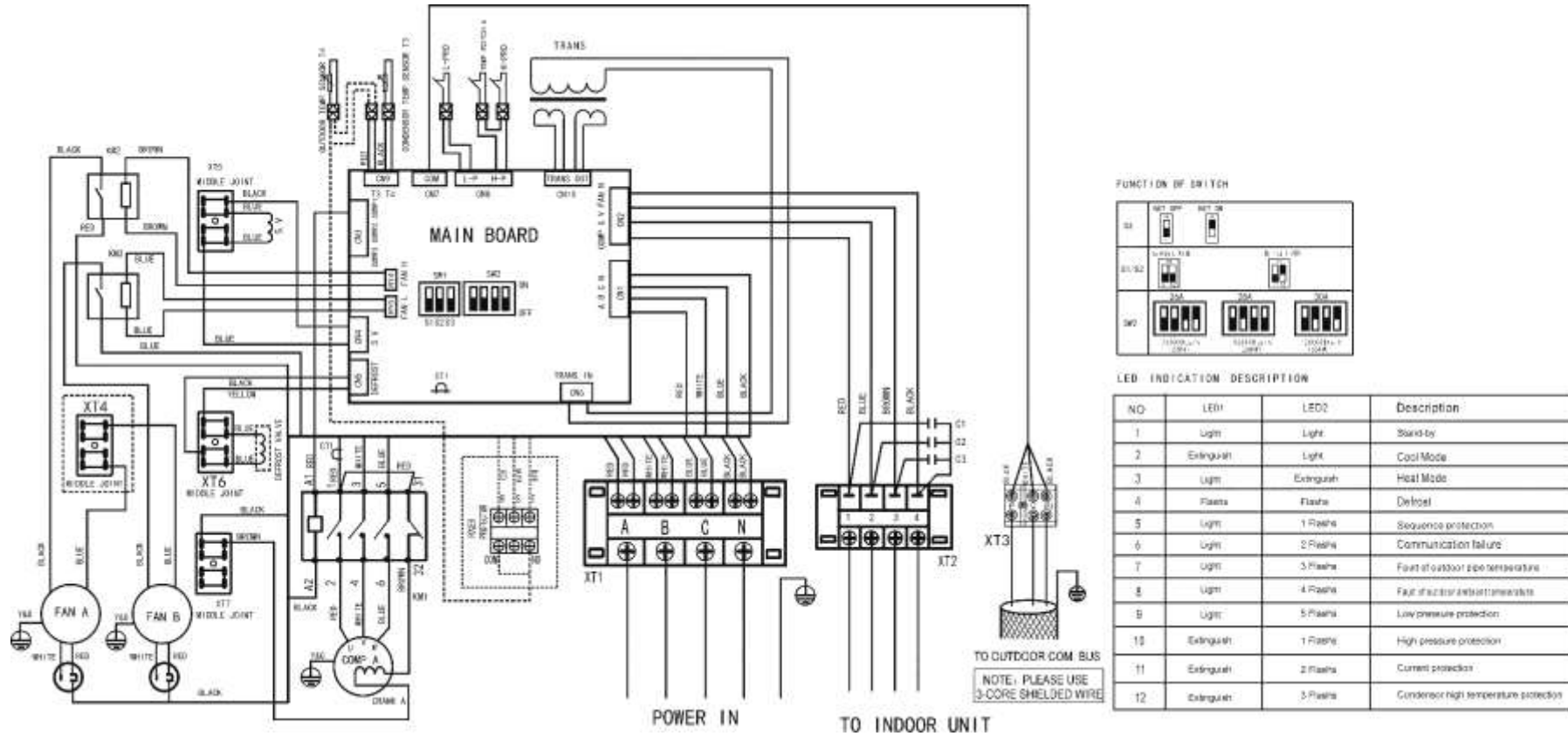

Note: The middle joint XT4 only exists when the frequency of outdoor unit power is 50Hz.

38LDU-140HN1

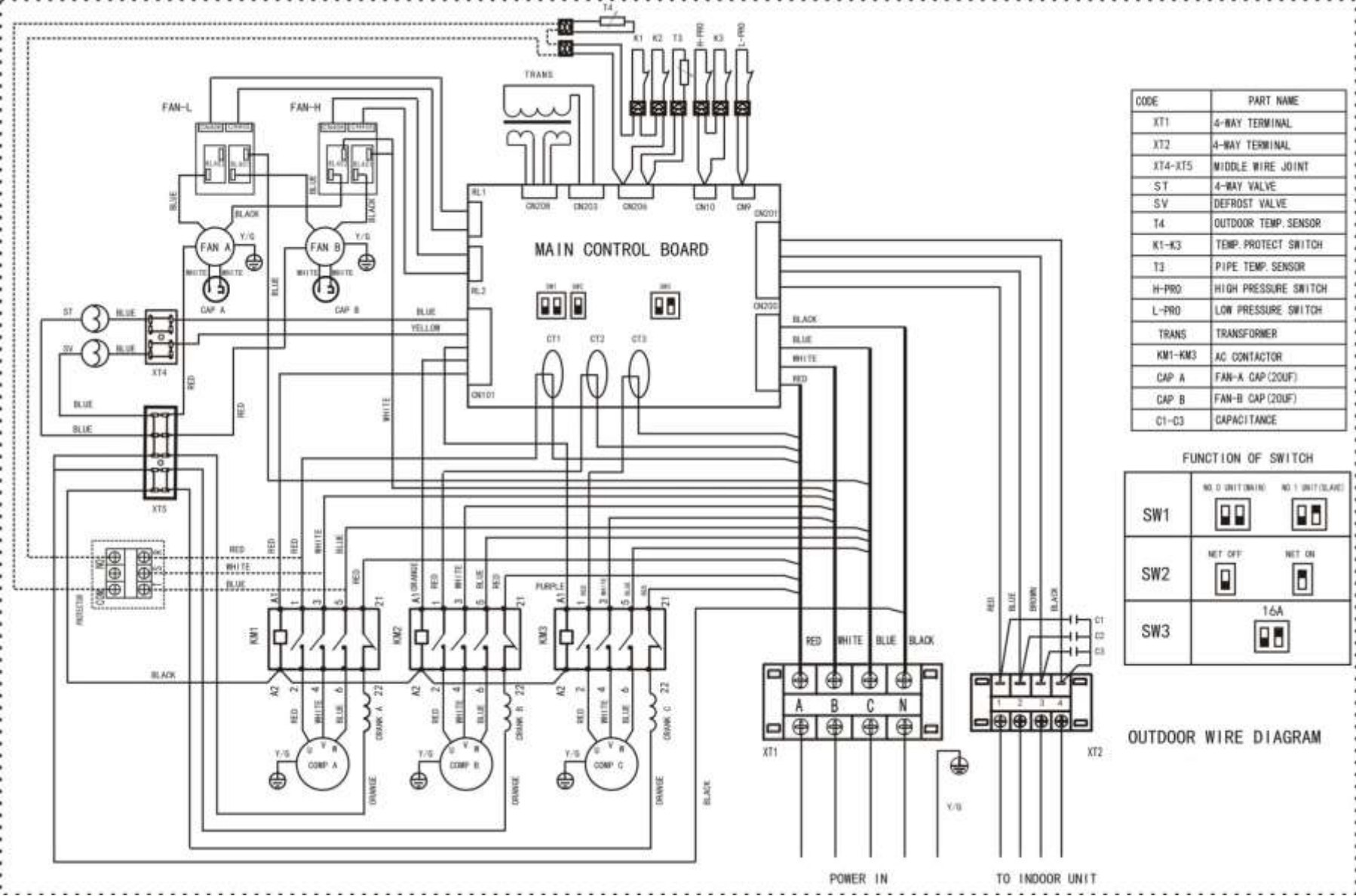

CODE	PART NAME
XT1	4-WAY TERMINAL
XT2	4-WAY TERMINAL
XT4-XT5	MIDDLE WIRE JOINT
S1	4-WAY VALVE
SV	DEFROST VALVE
T4	OUTDOOR TEMP. SENSOR
K1-K3	TEMP. PROTECT SWITCH
T3	PIPE TEMP. SENSOR
H-PRO	HIGH PRESSURE SWITCH
L-PRO	LOW PRESSURE SWITCH
TRANS	TRANSFORMER
KM1-KM3	AC CONTACTOR
CAP A	FAN-A CAP (20UF)
CAP B	FAN-B CAP (20UF)
C1-C3	CAPACITANCE

38LDU-170HN1

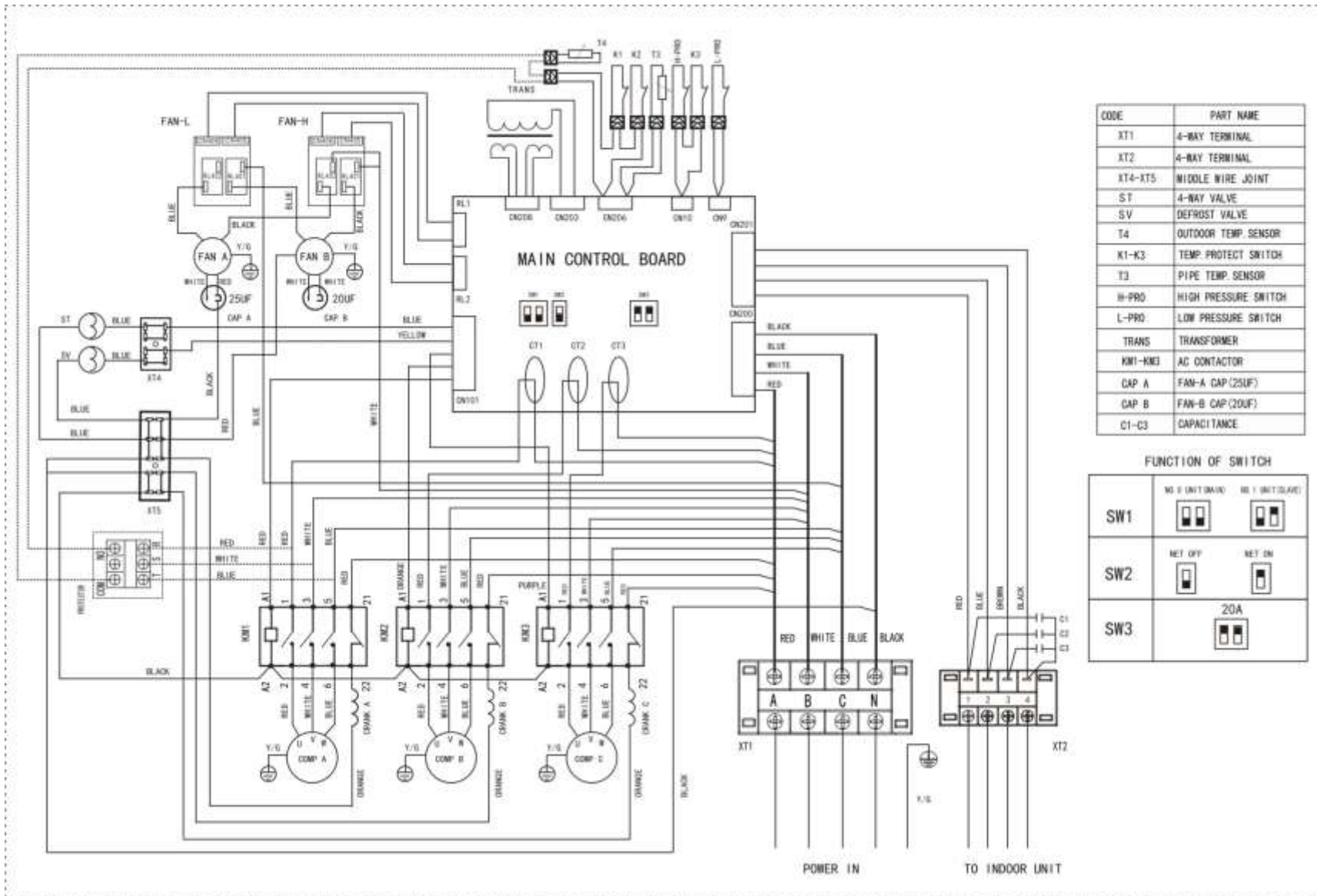

CODE	PART NAME
XT1	4-WAY TERMINAL
XT2	4-WAY TERMINAL
XT4-XT5	MIDDLE WIRE JOINT
ST	4-WAY VALVE
SV	DEFROST VALVE
T4	OUTDOOR TEMP SENSOR
K1-K3	TEMP. PROTECT SWITCH
T3	PIPE TEMP SENSOR
H-PRO	HIGH PRESSURE SWITCH
L-PRO	LOW PRESSURE SWITCH
TRANS	TRANSFORMER
KM1-KM3	AC CONTACTOR
CAP A	FAN-A CAP (25UF)
CAP B	FAN-B CAP (20UF)
C1-C3	CAPACITANCE

FUNCTION OF SWITCH

SW1	NO. 2 (NET MAIN) NO. 1 (NET SLAVE)
SW2	NET OFF NET ON
SW3	20A

5. Electric Characteristics

Model	Outdoor Unit				Power Supply			Compressor		OFM	
	Hz	Voltage	Min.	Max.	MCA	TOCA	MFA	MSC	RLA	KW	FLA
38LDU-70HN1	50	380-415V	342V	440V	15.5	19.3	21.2	86	12.3	0.42	2.6
38LDU-76HN1	50	380-415V	342V	440V	15.5	19.3	21.2	86	12.3	0.42	2.6
38LDU1-96HN1	50	380-415V	342V	440V	19.8	23.7	26.1	125	14.6	0.8	5.86
38LDU-140HN1	50	380-415V	342V	440V	37.1	47.9	52.7	62	8.8	0.76	5.48
38LDU-170HN1	50	380-415V	342V	440V	45.4	53.8	59.2	68	9.2	0.83	6.34

Remark:

MCA: Min. Current Amps. (A)

TOCA: Total Over-current Amps. (A)

MFA: Max. Fuse Amps. (A)

MSC: Max. Starting Amps. (A)

RLA: Rated Locked Amps. (A)

OFM: Outdoor Fan Motor.

FLA: Full Load Amps. (A)

KW: Rated Motor Output (kW)

6. Sound Levels

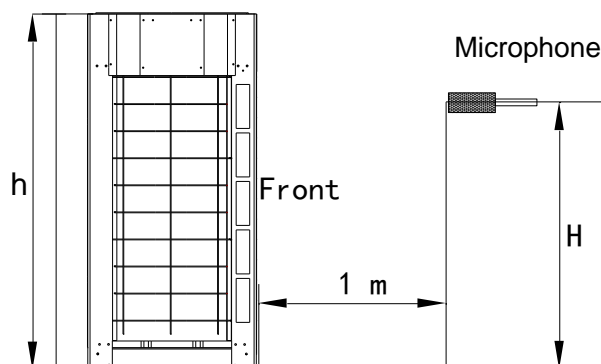

Note: $H = (h+1) / 2$

Model	Noise level
38LDU-70HN1	68 dB(A)
38LDU-76HN1	68 dB(A)
38LDU1-96HN1	68 dB(A)
38LDU-140HN1	70 dB(A)
38LDU-170HN1	73 dB(A)

Part. 5 Installation

1. Notes	50
2. Installation of Duct Type Indoor Units.....	51
3. Installation of Floor Standing Type Indoor Units	57
4. Installation of Outdoor Units.....	60
5. Connection of Refrigerant Pipe	62
6. Heat Insulation of Refrigerant Pipe	72
7. Electric Connection.....	73
8. Duct Design Scheme	77
9. Trial Run	80
10. Trouble shooting	81
11. Maintenance	94

1. Notes

CAUTION:

- ✧ Transport the air conditioner with the original package.
- ✧ Do not throw the remote controller and wired controller.
- ✧ If the air conditioner needs to be installed on a metal part of the building, electric insulation must be performed, and the installation must meet the relevant technical standards of electric devices.
- ✧ The unit must be installed 2.3m above floor and shall not be installed in the laundry.
- ✧ The enclosure of the appliance shall be marked by word, or by symbols, with the direction of fluid flow.
- ✧ An all-pole disconnection switch having a contact separation of at least 3mm in all poles should be connected in fixed wiring.
- ✧ Operate the remote controller within the receiving scope of the indoor unit, and direct the transmitting part of the remote controller to the receiver of the indoor unit.
- ✧ Install the unit where enough space of installation and maintenance is available.
- ✧ Install the unit where the ceiling is horizontal and enough for bearing the weight of the indoor unit.
- ✧ Install the unit where the air inlet and outlet are not baffled and the least affected by external air.
- ✧ Install the unit where the supply air flow can be sent to all parts in the room.
- ✧ Install the unit where it is easy to lead out the connective pipe and the drain pipe.
- ✧ Install the unit where no heat is emitted from a heat source directly.
- ✧ Installing the equipment in any of the following places may lead to faults of the equipment (if that is inevitable, consult the supplier):
 - ✓ The site contains mineral oils such as cutting lubricant.
 - ✓ Seaside where the air contains much salt.
 - ✓ Hot ring area where corrosive gases exist, e.g., sulfide gas.
 - ✓ Factories where the supply voltage fluctuates seriously.
 - ✓ Inside a car or cabin.

- ✓ Place like kitchen where oil permeates.
- ✓ Place where strong electromagnetic waves exist.
- ✓ Place where flammable gases or materials exist.
- ✓ Place where acid or alkali gases evaporate, or other special environments.
- ◇ Install the unit in a dry and well ventilated place.
- ◇ Install the unit where the bearing surface is level and can bear weight of the unit, and is suitable for installing the unit horizontally without increasing noise or vibration.
- ◇ Install the unit where the operation noise and the expelling of air do not affect neighbors.
- ◇ Install the unit where no flammable gas is leaked.6Install the unit where it is convenient for pipe connection and electric connection.

2. Installation of Duct Type Indoor Units

2.1 Installing indoor units

- ◇ As the following picture, when install the indoor unit, select the enough solid and level site with enough space for installation and maintance.
- ◇ The inspection orifice should be enough larger to maintenance and repair the unit.
- ◇ Ensure that the minimum drain gradient is over 1/100.

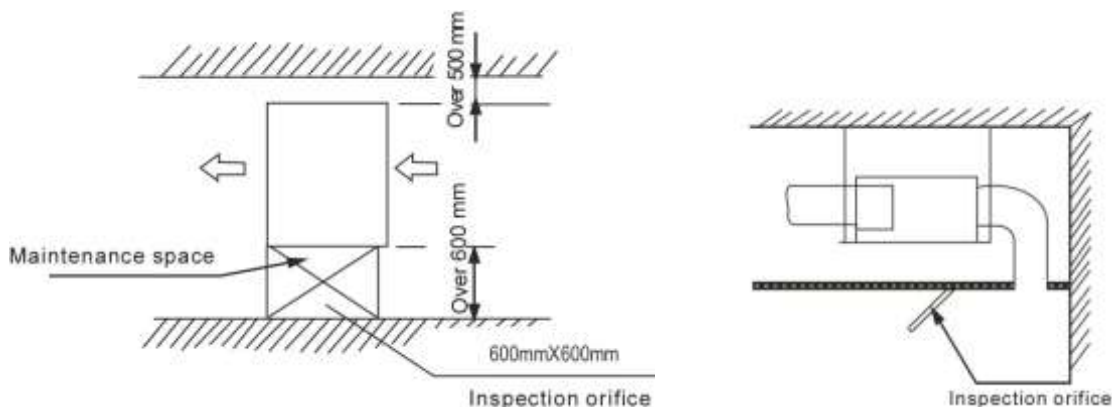

- ◇ Use $\Phi 10$ or bigger screws. The screw material is high-quality carbon steel whose surface is zinc plated or undergoes other anti-rust treatment, or stainless steel.
- ◇ Fix the pendant bolts firmly and reliably in light of the specific situation.
- ◇ The pendant bolt hole figure is as following picture.

42LDU-70HN1

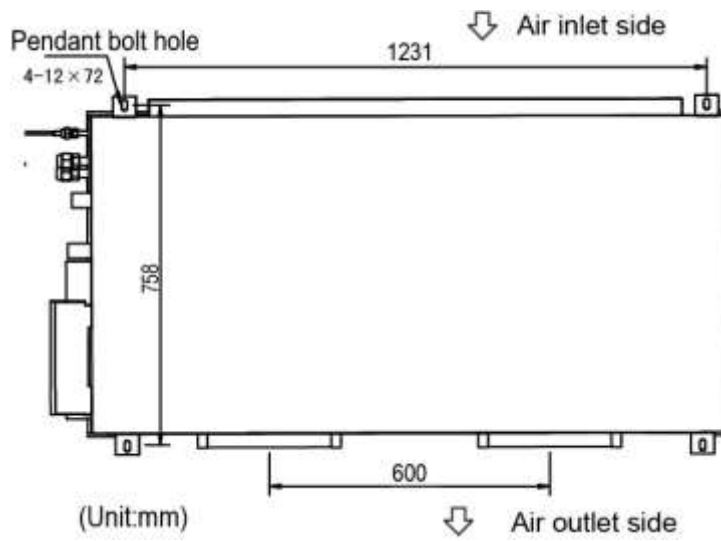

42LDU1-96HN1

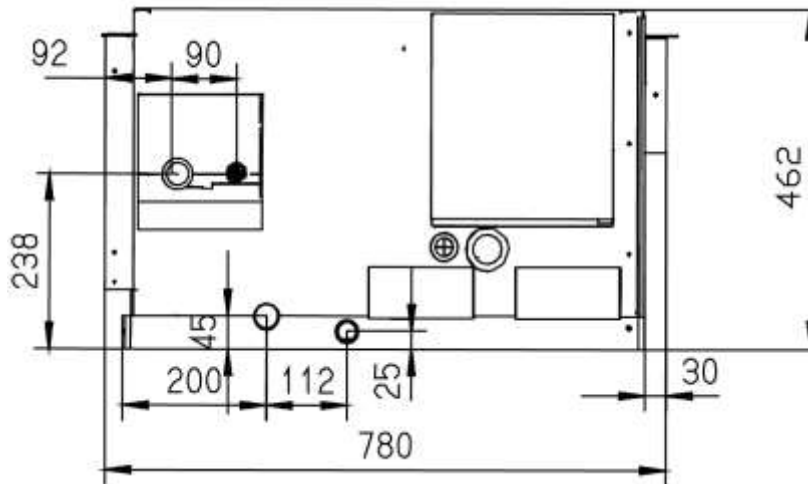

42LDU-140HN1, 42LDU-170HN1

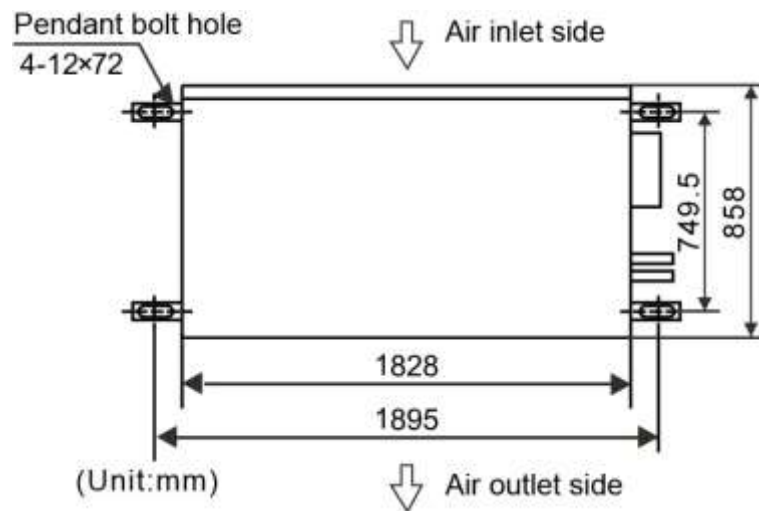

- ✧ When the pendant bolt is fixed in wooden structure, please put rectangular sticks across the beams, and set pendant bolts.

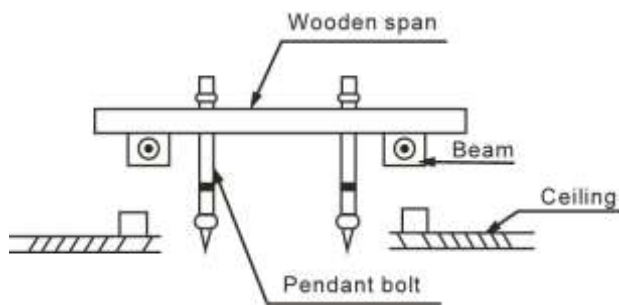

- ✧ When in the new concrete roughcast environment, please use embedded bolts, embedded pulling plugs and stick harness. On steel bar have some holes to hang pipe and embed screw bolts.

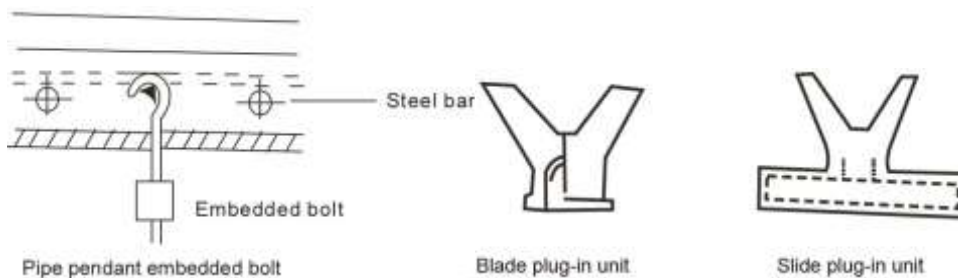

- ✧ When in steel beam and girder structure, set and use supportive angle steel.

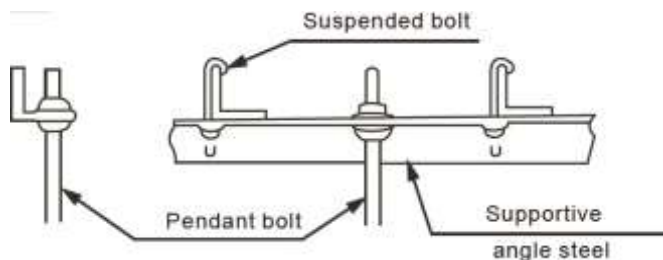

- ✧ After install the indoor units, use a hoisting device to hoist the indoor unit, and align it with the installation screws to adjust the horizontality. Finally, Tighten the screws.

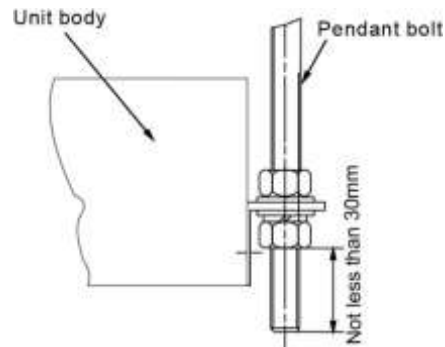

2.2 Designing and connecting the duct

- ✧ The duct accessories and materials must be produced by professional manufacturers.
- ✧ The duct design must comply with the national heating air conditioner pipeline design specifications.
- ✧ In order to prevent air flow shooting, do not set the air inlet orifice near the air outlet orifice.
- ✧ Install a filter at an easy-to-maintain place such as intake pipe. If without the filter, the duct will get clogged on the air heat exchanger and lead to fault and water leak of the air conditioner.
- ✧ In order to suppress noise effectively, install noise suppression and sound insulation devices, especially in the noise-sensitive spaces such as meeting rooms.
- ✧ For connection of the flange plane, use non-flammable canvas adapter to prevent transmission of vibration. Use M6×20 screws (configured on site) for connection.

Key points of duct connection

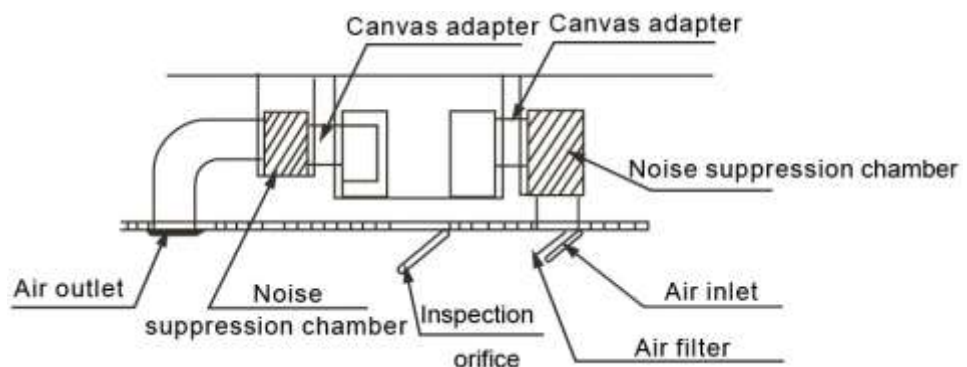

42LDU-70HN1, 42LDU1-96HN1

View of air outlet side (Unit: mm)

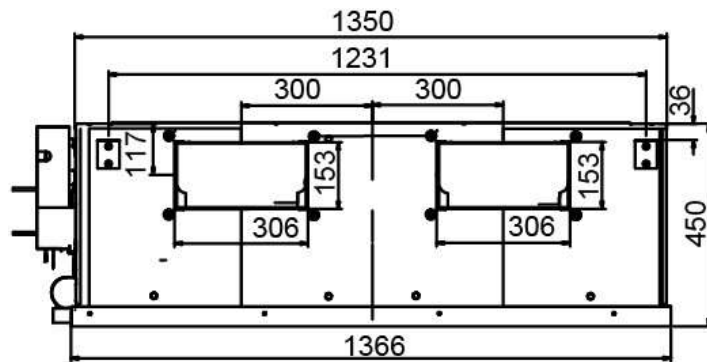

View of top side (Unit: mm)

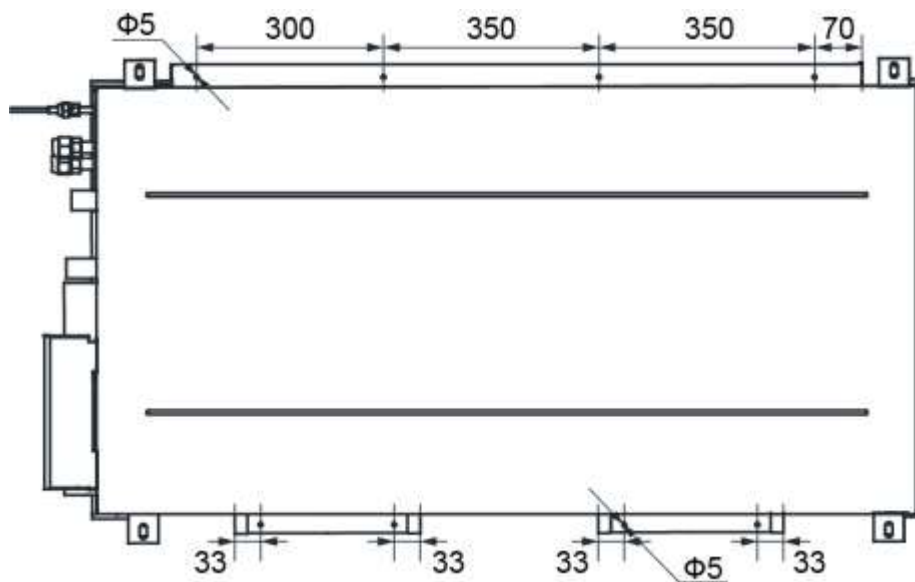

View of air inlet side

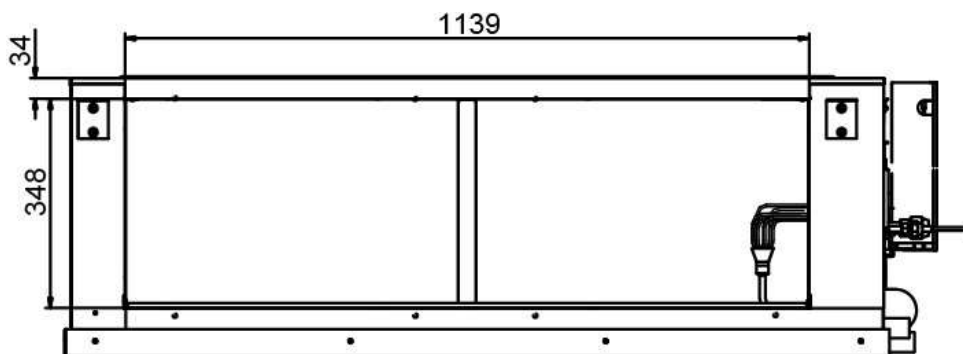

42LDU-140HN1

View of air outlet side (Unit: mm)

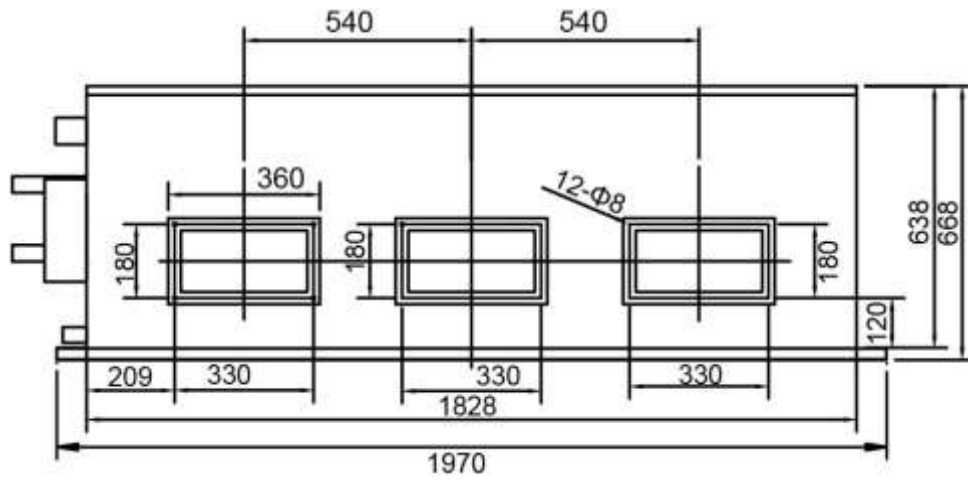

View of air inlet side (Unit: mm)

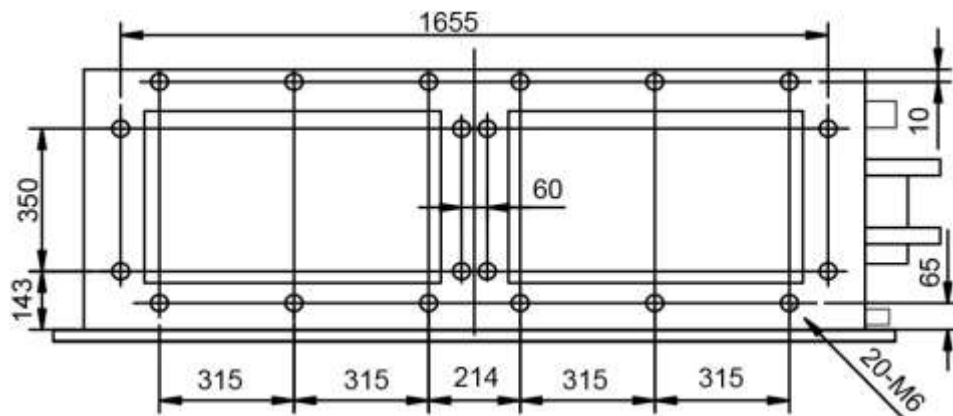

42LDU-170HN1

View of air outlet side (Unit: mm)

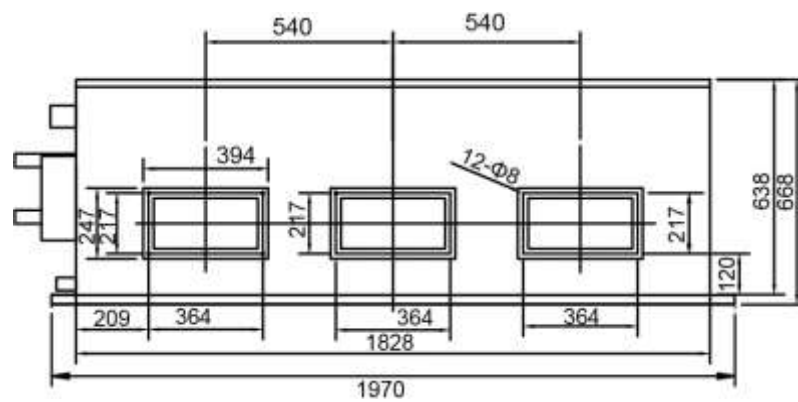

View of air inlet side (Unit: mm)

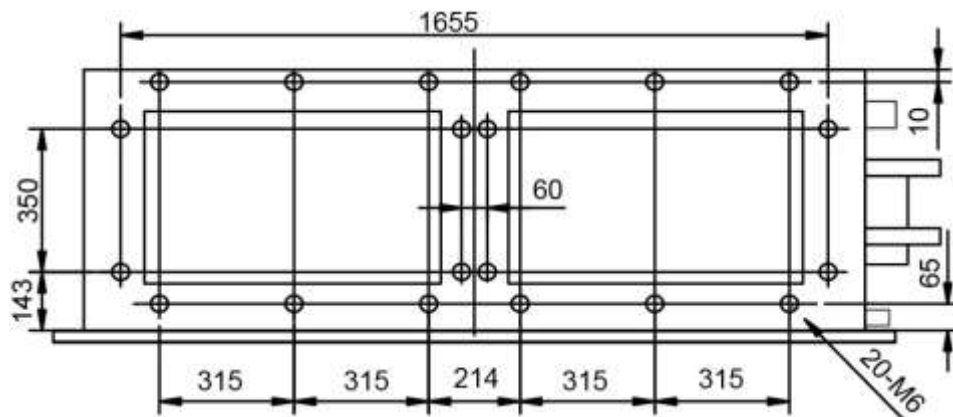

2.3 Install the drainage pipe

- ✧ Install a drain stream trap in the drainpipe to prevent water from overflowing.
- ✧ In order to prevent faults caused by condensate of the refrigerant pipe and drain pipe, perform condensate prevention and heat insulation properly.
- ✧ If it is forecast that high humidity and temperature environment (condensate temperature is over 23°C) may exist in the ceiling, e.g., inside the ceiling with slab, (ceiling which is in the same environment as the outdoor air), it is necessary to apply 10mm or thicker adiabatic wool (16~20kg/m²) to the refrigerant pipe and the drain pipe in addition to apply the general heat insulation materials. Enough heat insulation materials should also be applied to the refrigerant joint and the pipe joint.
- ✧ The drain of water is natural. In the construction, the external pipe slants downward at a gradient of 1/50~1/100.
- ✧ The number of bends and folds of the drain pipe should not exceed 2. Try to avoid bends in order to prevent trash accumulation. Furthermore, to reduce the depositing dust, avoid bending the pipe as possible.

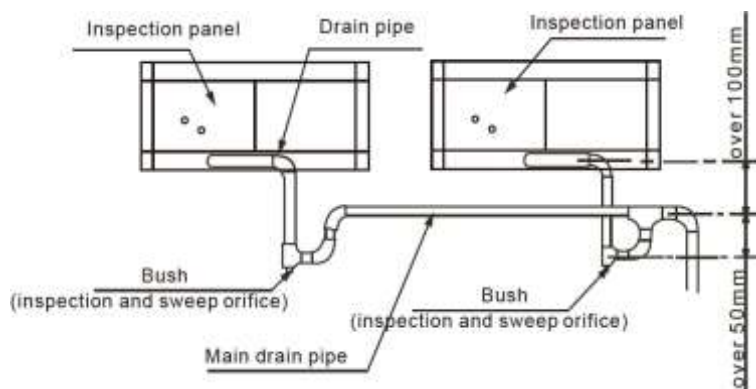

- ✧ Open the side panel of indoor unit to charge water into water collection tray, after the drain water pipe is installed, check whether the water can be drained smoothly and whether the joints are leakage.
- ✧ After making sure that the water drains smoothly and no water is leaked, use a diabatic wool bushes to preserve heat of the drain pipe. Otherwise, condensate will occur.

3. Installation of Floor Standing Type Indoor Units

3.1 Installing indoor units

- ✧ For ensure the proper installation, first select the enough solid and level site.
- ✧ Ensure enough space required for installation and maintenance.

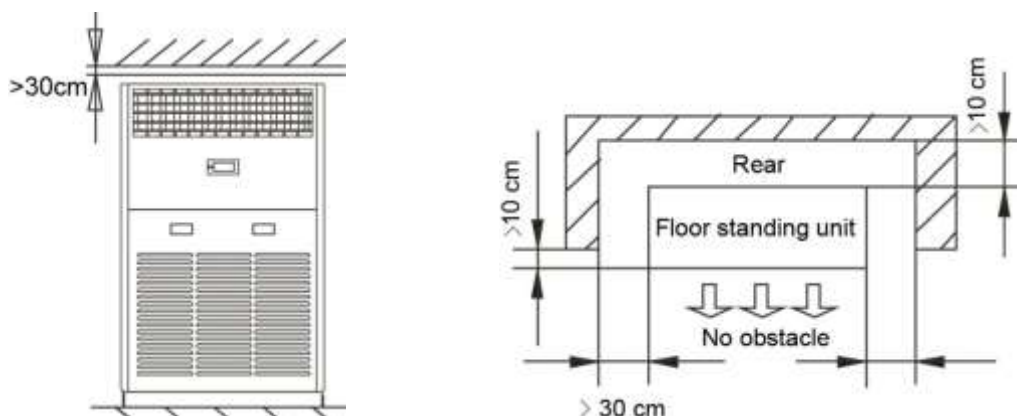

- ✧ For anti-fall down, please conduct the follow measure:
 - a. Fix the feet on the floor after select a proper place for installation, since the height of the unit casing is very high.
 - b. The right and left sides as weel as rear can be fixed, it is necessary to select the unit fixed measure as per to the actual installing ambient.

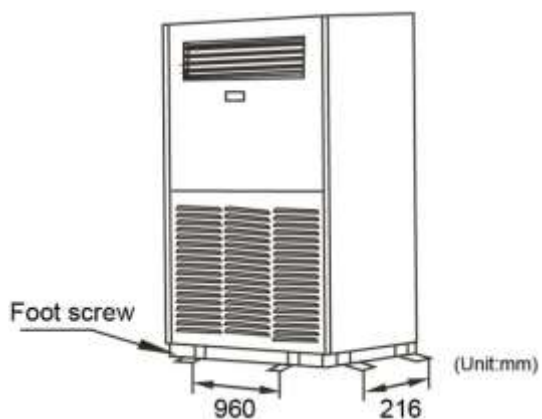

Notes:

It is be ware of the foot screw, which may be hurt for the passby people, make sure enough securit of that, prevent accident occure.

- ✧ Before electric connection, uncover the screw-cap in the air intake panel, and then lossen the screws.
- ✧ Take off the air intake panel, ensure which place secure enough will not make risk to the other people.

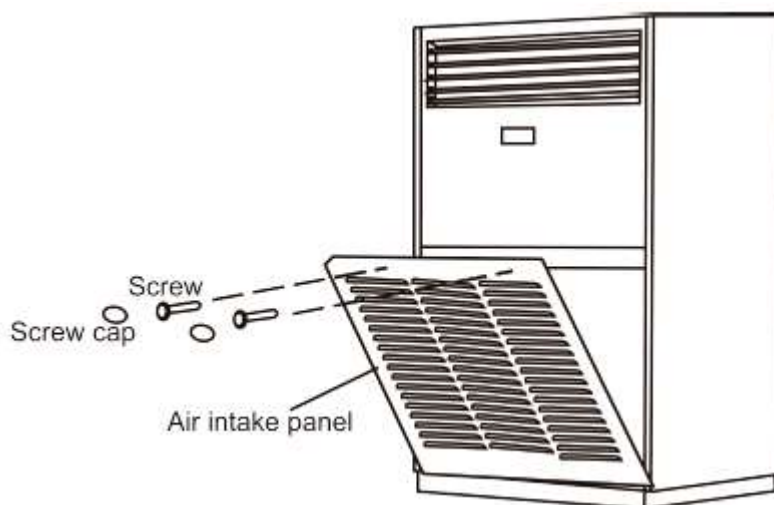

3.2 Install the drainage pipe

- ✧ There is natural drain, it is should be confirmed that the height of drain pipe is not higher than water collection tray.

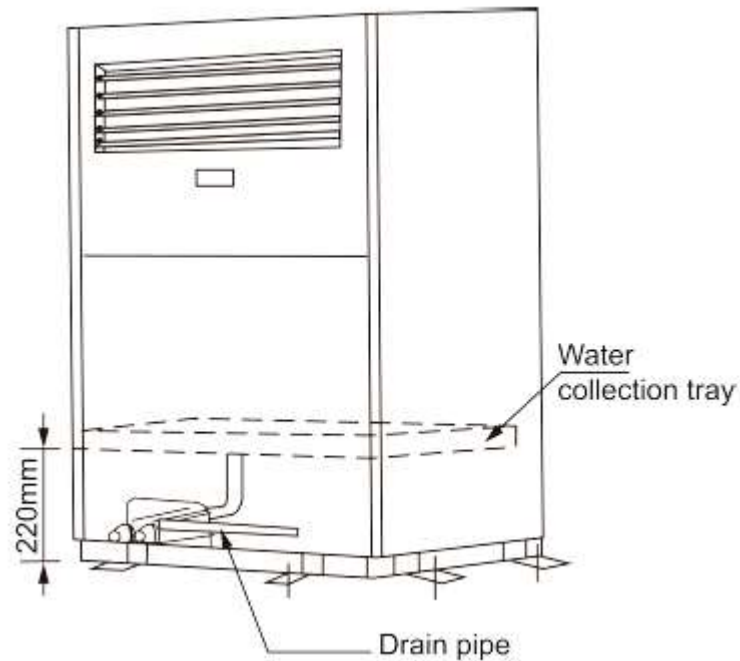

- ✧ The number of bends and folds of the drain pipe should not exceed 2. Try to avoid bends in order to prevent trash accumulation.
- ✧ Charge water into water collection tray, after the drain water pipe is installed, check whether the water can be drained smoothly and whether the joints are leakage.
- ✧ After making sure that the water drains smoothly and no water is leaked, use a diabatic wool bushes to preserve heat of the drain pipe. Ohterwise, condensate will occur.

4. Installation of Outdoor Units

- ✧ When installing the unit, leave a space for maintenance shown in the following figure. Install the power supply at the side of the outdoor unit.

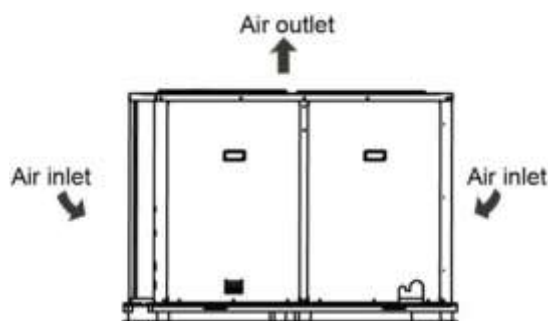

38LDU-70HN1

38LDU-76HN1

38LDU1-96HN1

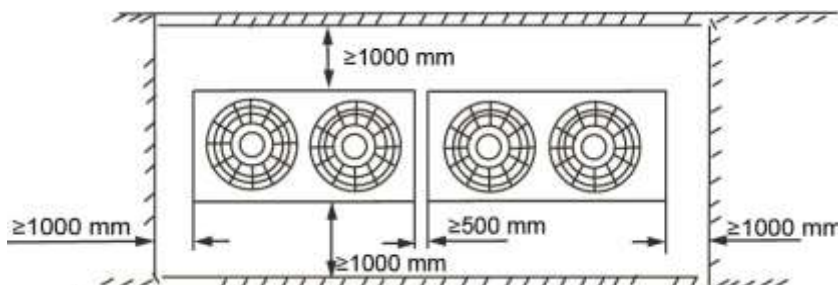
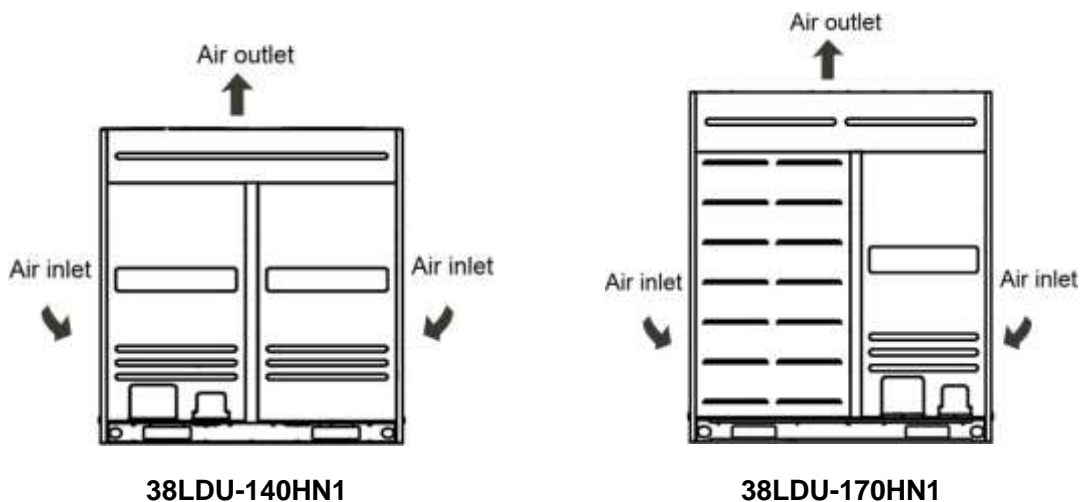

- ✧ In case any obstacles exist above the outdoor unit, such obstacles must be 2000mm above the outdoor unit.
- ✧ If miscellaneous articles are piled around the outdoor unit, such articles must be 400 mm below the top of the outdoor unit. Use 4 steel ropes of a diameter 6mm or bigger size to hoist the outdoor unit and move it into the site.
- ✧ In order to prevent scratch and deformity the outdoor unit, apply a guard board to the surface of contact between the steel wire and the air conditioner. Remove the cushion for use in the transport after finishing the transport.

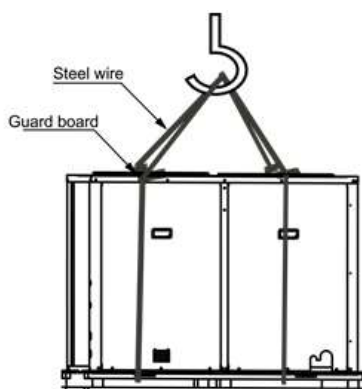

- ✧ The distance of the foundation bolt is shown in following picture. (Unit: mm)

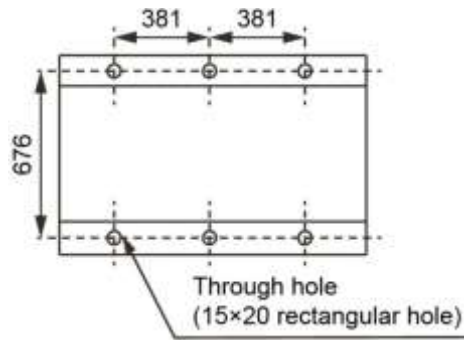

38LDU-070HN1, 38LDU-076HN1

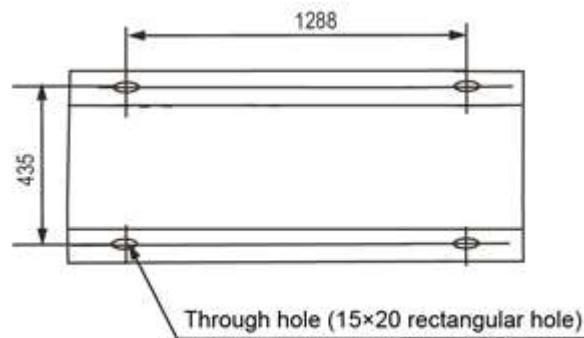

38LDU1-096HN1

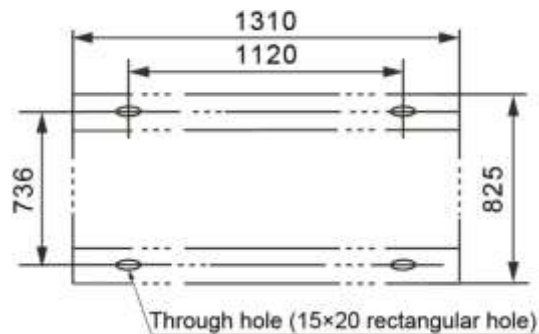

38LDU-140HN1

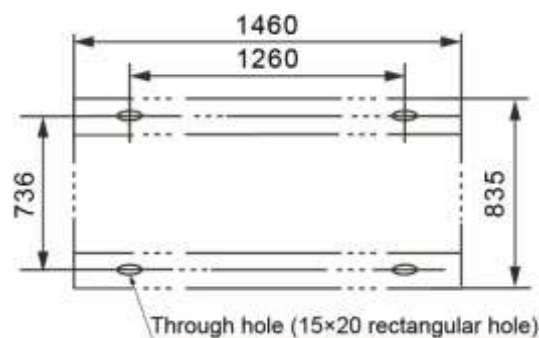

38LDU-170HN1

- ✧ As the following shown picture, leave an interval between the multi-outdoor unit.

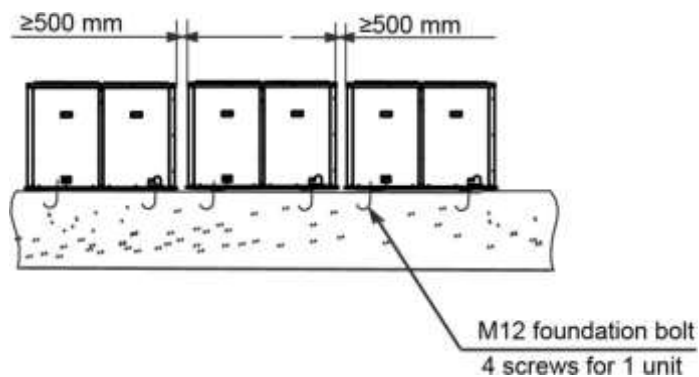

- ❖ Snow protection facilities must be installed in the snowfall areas. In order to prevent influence caused by snow, set up raised pavilion, and install snow protection sheds at the air inlet and air outlet. The snow protection facilities are provided in the site.

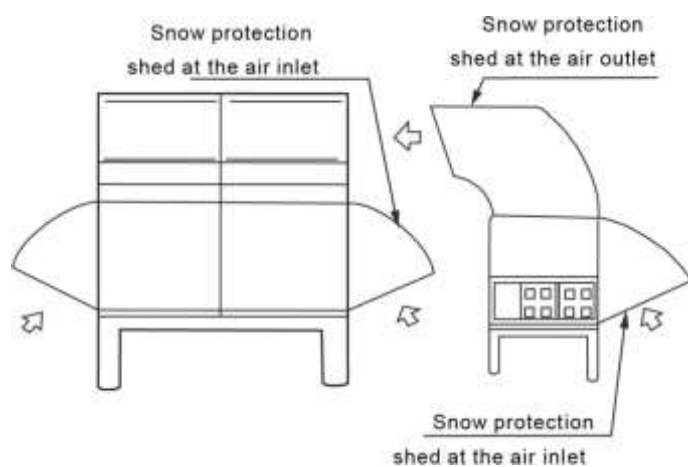

5. Connection of Refrigerant Pipe

- ❖ Schematic diagram of connection between indoor unit and outdoor unit:

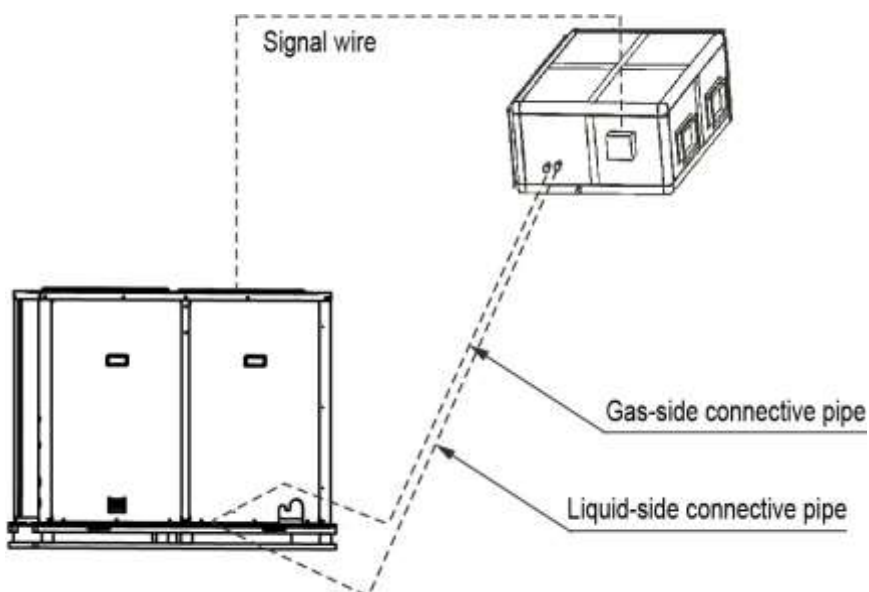

42LDU-70HN1 + 38LDU-70HN1

42LDU1-96HN1 + 38LDU1-96HN1

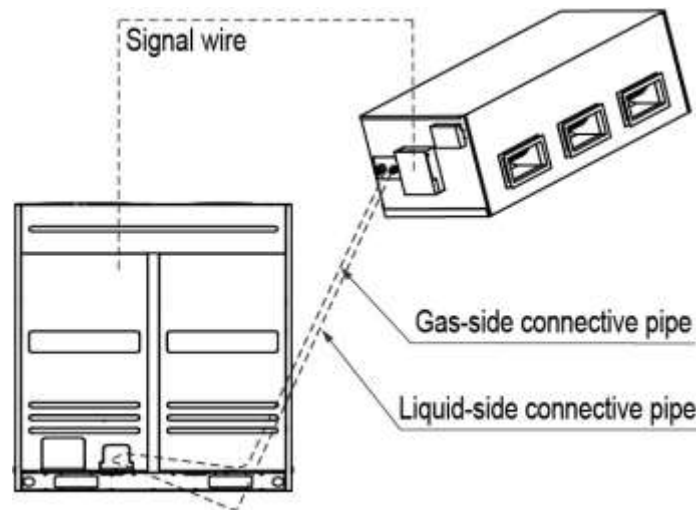

42LDU-140HN1 + 38LDU-140HN1

42LDU-170HN1 + 38LDU-170HN1

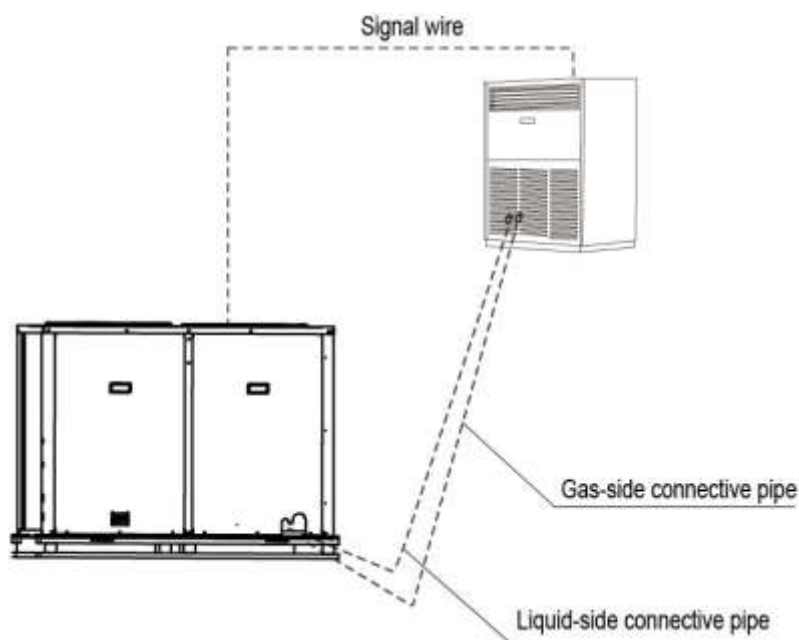

42CFS-76HN1 + 38LDU-76HN1

42CFS1-96HN1 + 38LDU1-96HN1

✧ The refrigerant pipe adapter is located inside the outdoor unit. So remove the right front board

first, and remove M5 screws.

- ✧ When the pipe is connected from the front side, the pipe can be led out through the right front board.
- ✧ When welding the refrigerant pipe, in order to prevent internal oxidation of the pipe, nitrogen must be filled in. Otherwise, the oxidized chips may block refrigerating circulatory system.
- ✧ Trash and foreign matters may come into the pipe in the process of installing the refrigerant pipe. Be sure to blow them off with nitrogen before connecting the pipe to the outdoor units.
- ✧ Use high-pressure nitrogen to clean the pipelines. Do not use the refrigerant of the outdoor unit for cleaning.
- ✧ Pipes size of the units.

Outdoor units	Liquid pipe	Gas pipe
38LDU-70HN1	Φ9.52mm	Φ22mm
38LDU-76HN1	Φ9.52mm	Φ22mm
38LDU-140HN1	Φ16mm	Φ32mm
38LDU-170HN1	Φ16mm	Φ32mm

Outdoor units	Liquid pipe	Gas pipe
38LDU1-096HN1	Φ9.52mm (pipe length L≤30m)	Φ25.4mm (pipe length L≤30m)
	Φ12.7mm (pipe length 30m<L≤50m)	Φ28.6mm (pipe length 30m<L≤50m)

- ✧ All connections between indoor unit and outdoor unit are copper-to copper and should be brazed with a phosphorous-copper alloy material such as Silfos-5 or equivalent. **Do not** use soft solder. The outdoor units have reusable valves on both the liquid and vapor connections. The total system refrigerant charge is retained within the outdoor unit during shipping and installation. The reusable valves are provided to evacuate and charge per the instruction.
- ✧ Dry nitrogen should always be supplied through the tubing while it is being brazed, because the temperature required is high enough to cause oxidation of the copper unless an inert atmosphere is provided. The flow of dry nitrogen should continue until the joint has cooled. Always use a pressure regulator and safety valve to insure that only low pressure dry nitrogen is introduced into the tubing. Only a small flow is necessary to displace air and prevent oxidation.
- ✧ Install the connective pipe only after fixing the indoor unit and outdoor unit. Keep dry when installing the connective pipe. Do not let moist intrude into the pipeline system.

- ◇ Allowed length of refrigerant pipe and height difference.

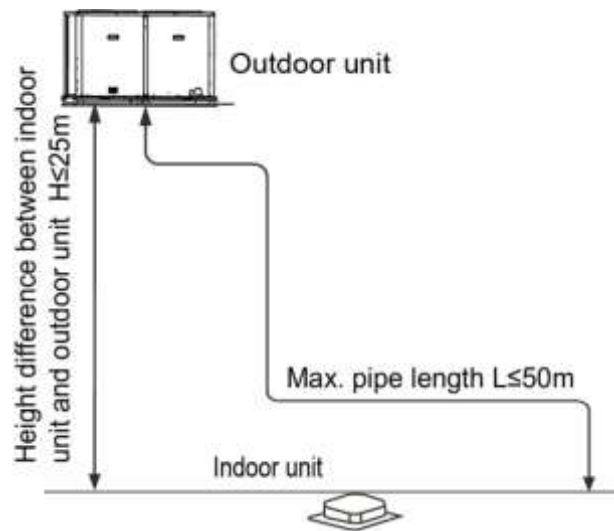

		Allowed value
Max. actual length of pipe (L)		50m
Max. height difference between indoor and outdoor unit	Outdoor unit (upper)	25m
	Outdoor unit (lower)	30m
Max. number of bends		15

- ◇ Do not increase or decrease piping sizes.
- ◇ As shown in following picture, when brazing the indoor and outdoor connective lines, pad a sheet metal under the valve avoids the flame burning the chassis.

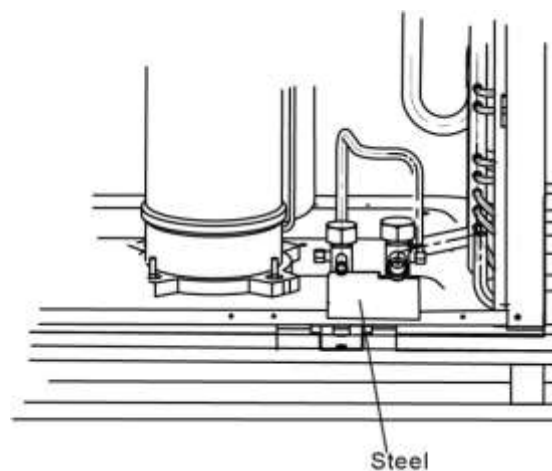

- ◇ Precaution should be taken to prevent heat damage to the valve by wrapping a wet rag around it. Remove the cap and Schrader core from both the liquid and vapor service valve service ports at the outdoor unit. Connect low pressure nitrogen to the liquid line service port.

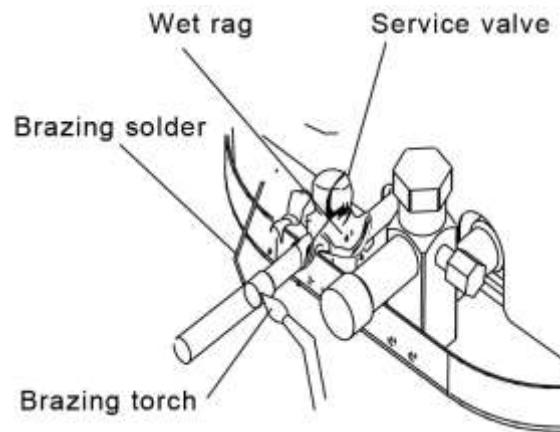

- ❖ Braze the liquid line to the high pressure valve (liquid valve) at the outdoor unit. Be sure to wrap the valve body with a wet rag. Allow the nitrogen to continue flowing.
- ❖ Carefully remove the rubber plugs from the evaporator liquid and vapor connections at the indoor unit.
- ❖ Braze the liquid line to the indoor liquid connection. Nitrogen should be flowing through the evaporator coil.
- ❖ Slide the plastic cap away from the vapor connection at the indoor coil. Braze the vapor line to the evaporator vapor connection.
- ❖ Protect the vapor valve with a wet rag and braze the vapor line connection to the outdoor unit. The nitrogen flow should be exiting the system from the vapor service port connection. After this connection has cooled, remove the nitrogen source from the liquid fitting service port.
- ❖ Replace the Schrader core in the liquid and vapor valves.
- ❖ Leak test all refrigerant piping connections including the service port flare caps to be sure they are leak tight.
- ❖ Do not over tighten. (between 40 and 60 inch-lbs. maximum)
- ❖ Evacuate the vapor line, evaporator and the liquid line, to 500 microns or less.
- ❖ Replace cap on service ports. Do not remove the flare caps from the service ports except when necessary for servicing the system.
- ❖ Do not connect manifold gauges unless trouble is suspected. Approximately 3/4 ounce of refrigerant will be lost each time a standard manifold gauge is connected.
- ❖ Release the refrigerant charge into the system. Open both the liquid and vapor valves by removing the plunger cap and with a hex wrench back out counter-clockwise until valve stem

just touches the chamfered retaining wall.

- ✧ Replace plunger cap finger tight, then tighten an additional 1/12 turn (1/2 hex flat). Cap must be replaced to prevent leaks.
- ✧ Never attempt to repair any brazed connections while the system is under pressure. Personal injury could result.
- ✧ After the pipes between the indoor unit and the outdoor unit are connected, replenish compressed nitrogen to perform airtight test.
 - ✓ The airtight test is performed by using the compressed nitrogen, 2.94MPa (30kg/cm²G). Leak test with a bubble type leak detector. Do not use the system refrigerant in the outdoor unit to purge or leak test.
 - ✓ Tighten the spool of the low pressure valve and high pressure valve before compressing the nitrogen.
 - ✓ Compress the nitrogen at the air vent of the gas valve.
 - ✓ The low pressure valve and high pressure valve are closed in the process of compressing the nitrogen.
 - ✓ **Do not** use oxygen, flammable gas or toxic gas in the airtight test.

✧ Vacuum

Length of connective pipe (Single pass)	Procedure of expelling air
Less than 5m	Use refrigerant in the outdoor unit.
5~15m	Use vacuum pump or refrigerant tank.

Note: If the air conditioner is relocated, be sure to use a vacuum pump or refrigerant tank to expel air.

- ✓ Use the refrigerant in the outdoor unit to expel air.

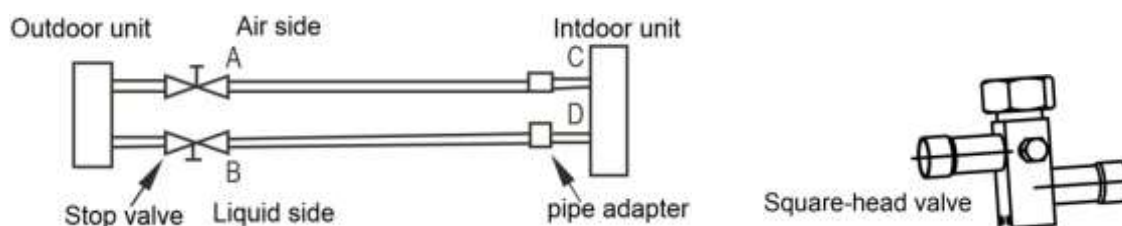

- Screw up the pipe nuts at A, B, C and D completely.
- Loosen and remove the square-head cover of valves A and B, rotate the square-head

spool of valve B counter-clockwise for 45 degrees and stay for about 10 seconds, and then close the spool of valve B tightly.

- Detect leak for all adapters at A, B, C and D. After making sure that no leak exists, open the maintenance orifice nut of valve A. After all air is expelled, tighten the maintenance orifice nut of valve A.
 - Open the spools of valves A and B completely.
 - Tighten the square-head cover of valves A and B completely.
- ✓ Use refrigerant tank to expel air.
- Screw up the pipe nuts at A, B, C and D completely.
 - Loosen and remove the square-head cover and maintenance orifice nut of valves A and B.
 - Connect the filler hose of refrigerant tank with the maintenance orifice of valve A.
 - Loosen the valve of the refrigerant tank, continue filling refrigerant for 6 seconds to expel the air, and tighten the nut of valve B quickly.
 - Loosen the valve of the refrigerant tank again, and fill the refrigerant for 6 seconds. Detect leak for all adapters at A, B, C and D. After making sure that no leak exists, screw off the filler hose. After all the filled refrigerant is expelled, screw up the maintenance orifice nut of valve A quickly.
 - Open the square-head pools of valves A and B completely.
 - Tighten the square-head cover of valves A and B.
- ✓ Use a vacuum pump

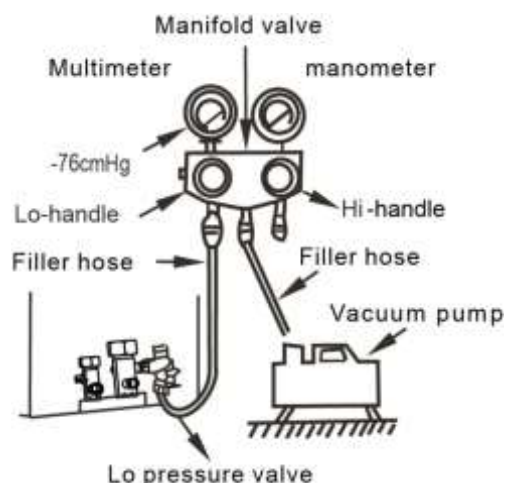

- Loosen and remove the maintenance orifice nut of valve A, and connect the filler hose of the manifold valve to the maintenance orifice of valve A (Tighten both valve A and valve B).
 - Connect the filler hose adapter to the vacuum pump.
 - Open the low (Lo) pressure handle of the manifold valve completely.
 - Start the vacuum pump to extract air. At the beginning of extracting air, slightly loosen the maintenance orifice nut of valve B, check whether any air enters it (The vacuum pump noise changes, and the multi-meter indicates from negative to 0.). Then tighten this maintenance orifice nut.
 - Upon completion of vacuuming, tighten the low pressure handle of the manifold valve completely and stop the vacuum pump. Keep extracting air for over 15 minutes. Check whether the multi-meter points at $-1.0 \times 10 \text{Pa}$ (-76cmHg).
 - Loosen and remove the square-head cover of valves A and B. After opening valves A and B completely, tighten the square-head cover of valves A and B.
 - Remove the filler hose of the maintenance orifice of valve A, and then tighten the nut.
- ✧ Procedure of using stop valve
- ✓ Open the spool until it touches the stop block. Do not attempt to open further.
 - ✓ Use a spanner or a similar tool to tighten the bonnet.
 - ✓ Upon completion of installation, open all valves before trial run. Each unit has two valves of different sizes located at the outdoor unit side. Of the two valves, one is gas valve and the other is liquid valve. The procedure of opening / closing the valve is shown in following picture.
 - ✓ Procedure of opening the valve: Open the square-head cover, use a spanner to capture the square head and open it thoroughly. Then tighten the square-head cover.
 - ✓ Procedure of closing the valve: Same as the procedure of opening the valve, but rotate the spanner clockwise thoroughly.

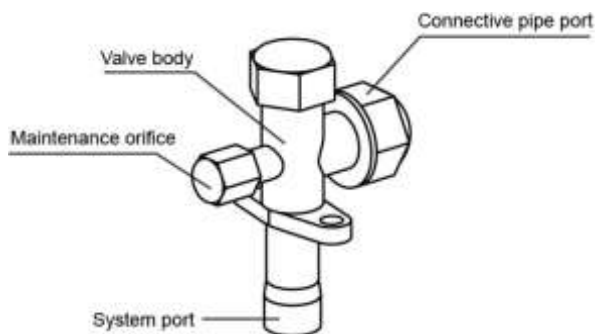

- ✧ After vacuum, according to the diameter and length of the connective pipe of liquid side between the indoor unit and outdoor unit, calculate the refrigerant replenishment quantity. The refrigerant for replenishment is R410A.

Diameter of liquid-side pipe	Quantity of refrigerant replenished for 1m pipe length
Φ9.52mm	0.06kg
Φ12.7mm	0.12kg
Φ16mm (38LDU-140HN1)	0.18kg
Φ16mm (38LDU-170HN1)	0.20kg

Note:

Please check and record the replenished quantity of the air conditioner.

- ✧ Refrigerant leak precautions. This air conditioner uses refrigerant R22. R22 is safe refrigerant which is harmless and non-flammable. The room for placing the air conditioner should have a proper space. Even if refrigerant leakage occurs, the density threshold will not be crossed.

Additional measures may also be taken.

- ✓ Density threshold: Density of the Freon gas that does not harm the human body. Density threshold of R410A: 0.3kg/m³.
- ✓ Calculate the total quantity of refrigerant to be replenished [A (kg)].
Total refrigerant quantity = refrigerant replenishment quantity upon shipment + additional refrigerant replenishment corresponding to the pipe length.
- ✓ Calculate out the indoor volume [B (m³)] (according to the minimum volume)
- ✓ Calculate out the refrigerant density:
 $[A \text{ (kg)}] / [B \text{ (m}^3)] \leq \text{Density threshold: } 0.3\text{kg/m}^3$
- ✓ Measures against crossing of the refrigerant density threshold.

- ✓ In order to keep the refrigerant density below the threshold value, please install a mechanic ventilation device. (Perform ventilation often.)
- ✓ In case frequent ventilation is impossible, please install the leakage detection alarm device linked with the mechanical ventilation device.

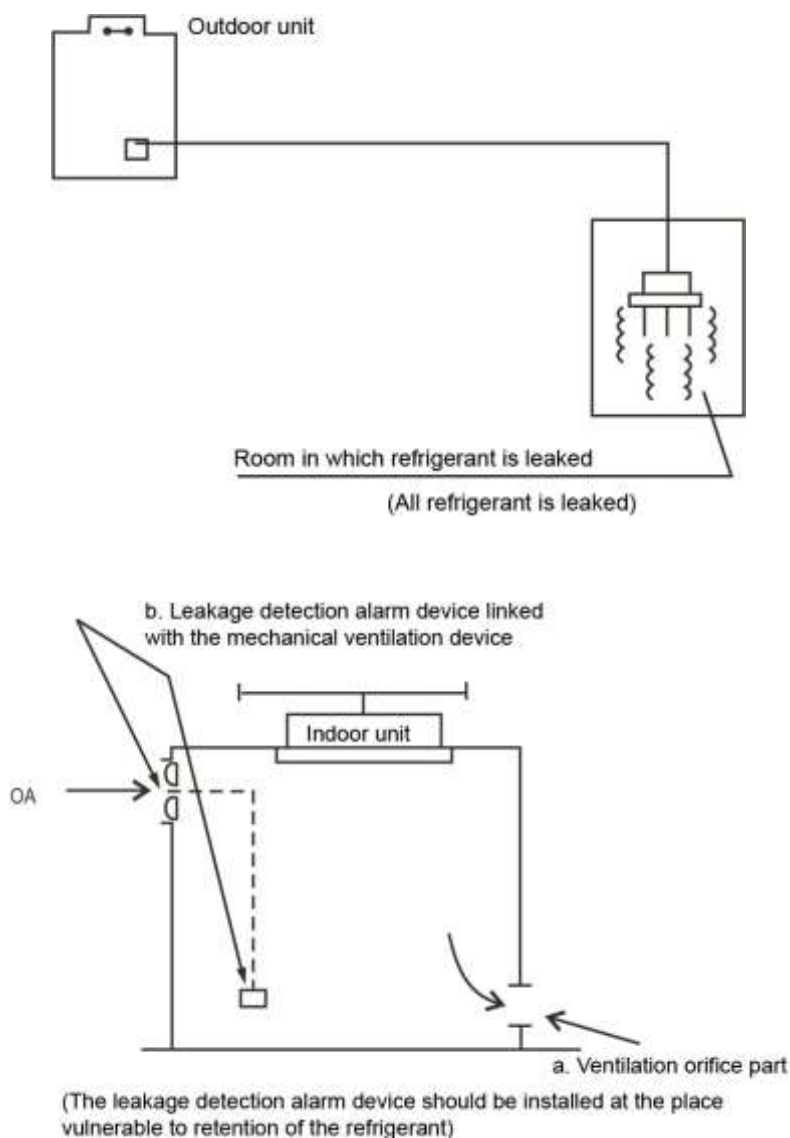

6. Heat Insulation of Refrigerant Pipe

In order to prevent faults caused by condensate of the refrigerant pipe and drain pipe, perform condensate prevention and heat insulation properly. If it is forecast that high humidity and temperature environment (Condensate temperature is over 23°C) may exist in the ceiling, e.g., inside the ceiling with slab, ceiling which is in the same environment as the outdoor air. It is necessary to apply 10mm or thicker adiabatic wool (16~20kg/m²) to the refrigerant pipe and the drain pipe in addition to applying the general heat insulation materials. Enough heat insulation materials should

also be applied to the refrigerant joint and the pipe joint.

Note: the heat insulation of drain pipe refer to the installation of indoor unit.

- ✧ Please use heat-resistant materials as heat insulation material of the air-side pipe. (e.g., EPT)
- ✧ Cover heat insulation materials separately at the liquid side and the air side. Moreover, perform heat insulation thoroughly for the air-side pipes of the indoor unit, and prevent water from dripping outside the unit.
- ✧ After applying the auxiliary heat insulation materials, use vinyl resin tape to seal refrigerant pipe and drainage pipe to prevent water leak.

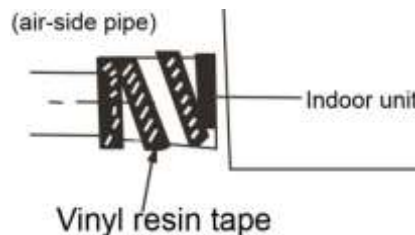

7. Electric Connection

7.1 Caution

- ✧ Use special power supply for the air conditioner. Design power supplies specific to the indoor unit and outdoor unit. The supply voltage must comply with the nominal voltage.
- ✧ The external supply circuit of the air conditioner must have a ground wire, and the power supply ground wire of the indoor unit must be connected with the external ground wire firmly.
- ✧ The wiring must be performed by professional technicians according to the circuit diagram labels.
- ✧ Distribute the wires according to the relevant electric technical standards promulgated by the State, and set the Residual Current-operated Circuit Breaker (RCCB) properly.
- ✧ The power wire and the signal wire shall be laid out neatly and properly, without mutual interference or contacting the connection pipe or valve.
- ✧ No power cable is attached to this equipment. The user can select the power cable by reference to the stipulated power supply specifications. No joint of wires is allowed.
- ✧ Upon completion of wire connection, double check it and then connect the power supply.
- ✧ An all-pole disconnection device which has at least 3mm separation distance in all pole and a residual current device (RCD) with the rating of above 10mA shall be incorporated in the fixed

wiring according to the national rule.

- ◇ The appliance shall be installed in accordance with national wiring regulations.

7.2 Specifications of power supply

Type	Indoor unit	Outdoor unit
Model	42LDU-70HN1	38LDU-70HN1
Power	220-240V~, 1Ph, 50Hz	380-415V~, 3Ph, 50Hz
Switch capacity of the main power supply / Fuse	20A/10A	60A/40A
Indoor unit power cable	3×2.5mm ² (Includes grounded wire)	\
Outdoor unit power cable includes grounded wire	\	5×6mm ²
Connective wire of indoor and outdoor unit	4×1.0mm ²	
Wire controller connective wire	5×0.5mm ² (Shield wire)	\

Type	Indoor unit	Outdoor unit
Model	42LDU1-96HN1	38LDU1-96HN1
Power	220-240V~, 1Ph, 50Hz	380-415V~, 3Ph, 50Hz
Switch capacity of the main power supply / Fuse	20A/10A	70A/50A
Indoor unit power cable	3×2.5mm ² (Includes grounded wire)	\
Outdoor unit power cable includes grounded wire	\	5×10mm ²
Connective wire of indoor and outdoor unit	4×1.0mm ²	
Wire controller connective wire	5×0.5mm ² (Shield wire)	\

Type	Indoor unit	Outdoor unit
Model	42LDU-140HN1	38LDU-140HN1
Power	220-240V~, 1Ph, 50Hz	380-415V~, 3Ph, 50Hz
Switch capacity of the main power supply / Fuse	20A/12A	70A/50A
Indoor unit power cable	3×2.5mm ² (Includes grounded wire)	\
Outdoor unit power cable includes grounded wire	\	5×16mm ²
Connective wire of indoor and outdoor unit	4×1.0mm ²	
Wire controller connective wire	5×0.5mm ² (Shield wire)	\

Type	Indoor unit	Outdoor unit
Model	42LDU-170HN1	38LDU-170HN1
Power	220-240V~, 1Ph, 50Hz	380-415V~, 3Ph, 50Hz
Switch capacity of the main power supply / Fuse	20A/12A	70A/50A
Indoor unit power cable	3×2.5mm ² (Includes grounded wire)	\
Outdoor unit power cable includes grounded wire	\	5×16mm ²
Connective wire of indoor and outdoor unit	4×1.0mm ²	
Wire controller connective wire	5×0.5mm ² (Shield wire)	\

7.3 Schematic diagram

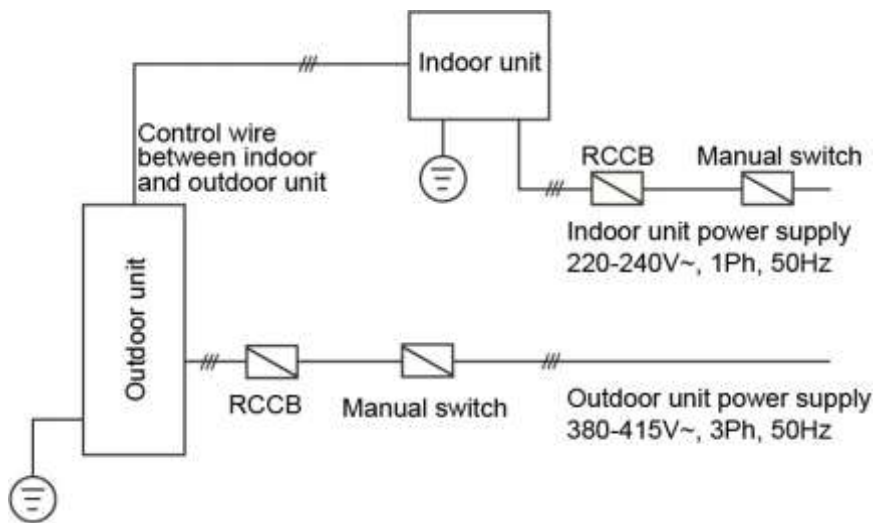

7.4 Electric wire diagram

When connect the wire, pay attention to the phase sequence of the power supply. If the phase sequence is reversed, the compressor will not start. Meanwhile, the fault indicator of the outdoor electric control board will light up. After shifting the phase sequence, power on the unit until the fault indicator goes out and the compressor starts up normally.

Duct type:

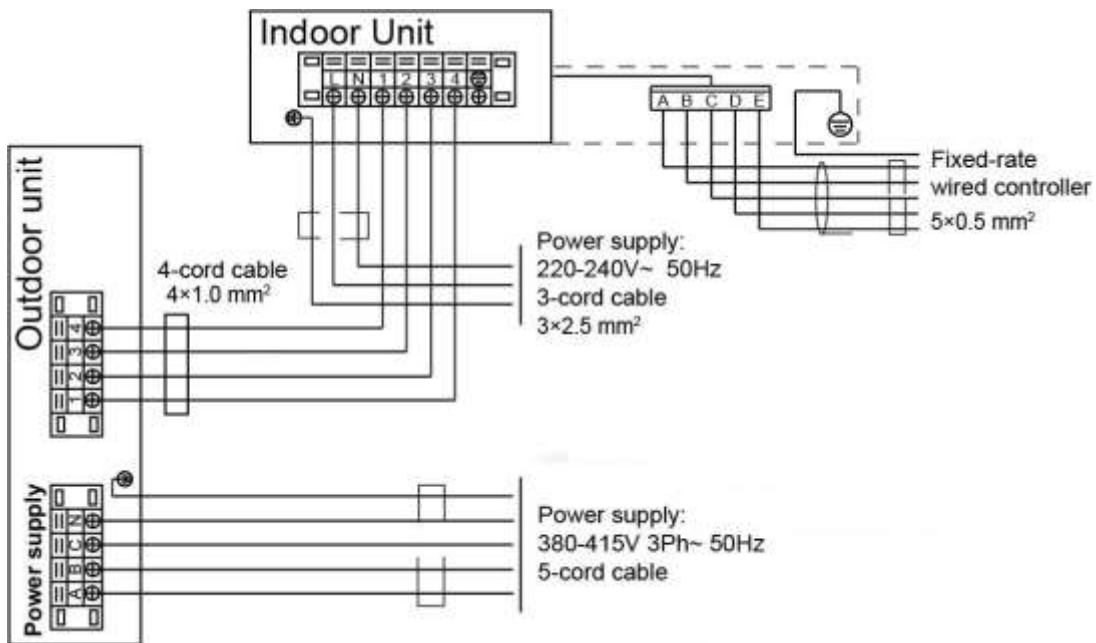

Floor standing type:

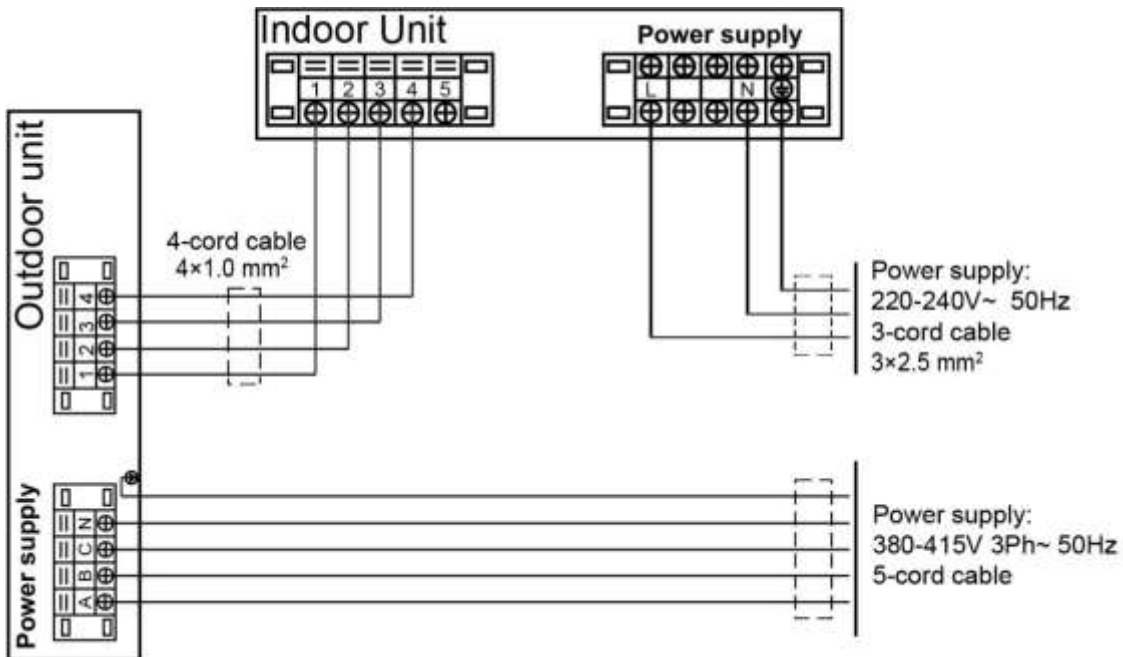

8. Duct Design Scheme

It is only available for duct type indoor unit.

Examples of construction and ventilation pipeline design scheme (Flowering hidden series.)

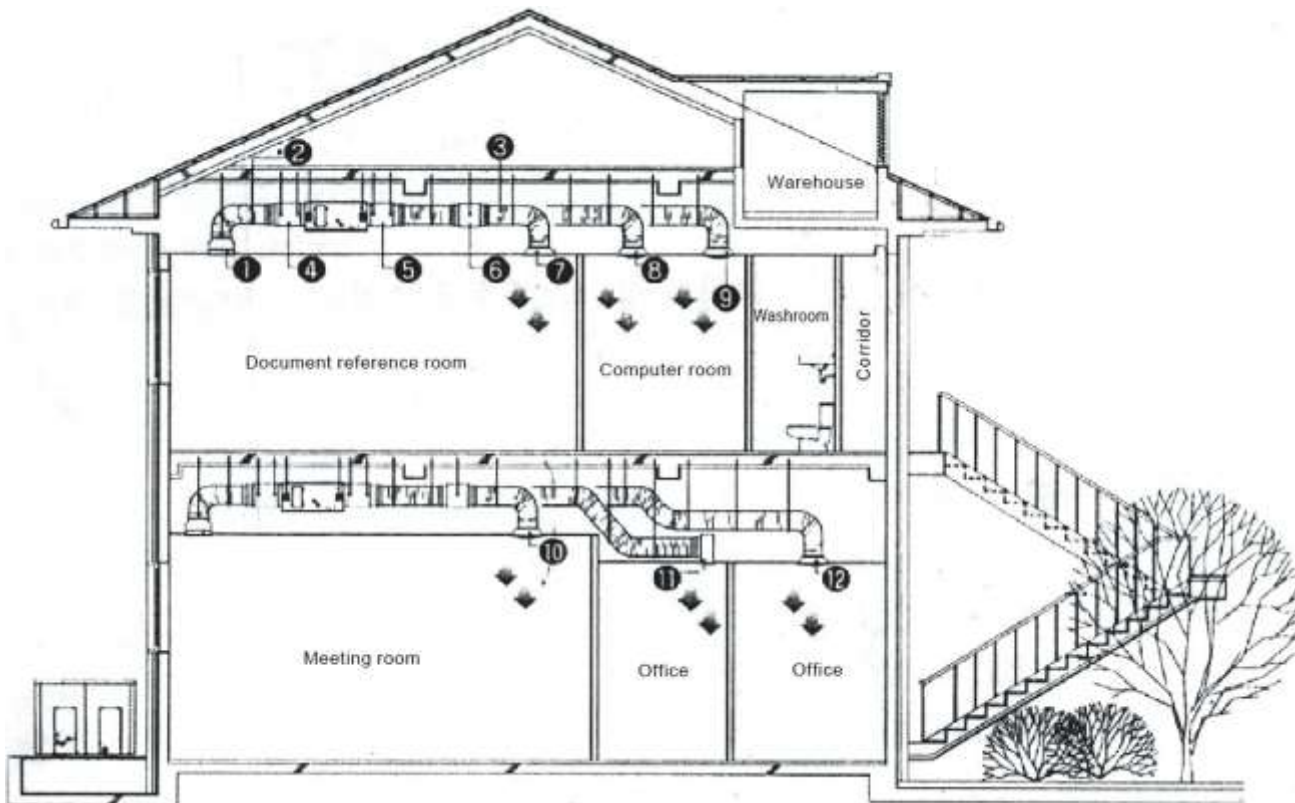



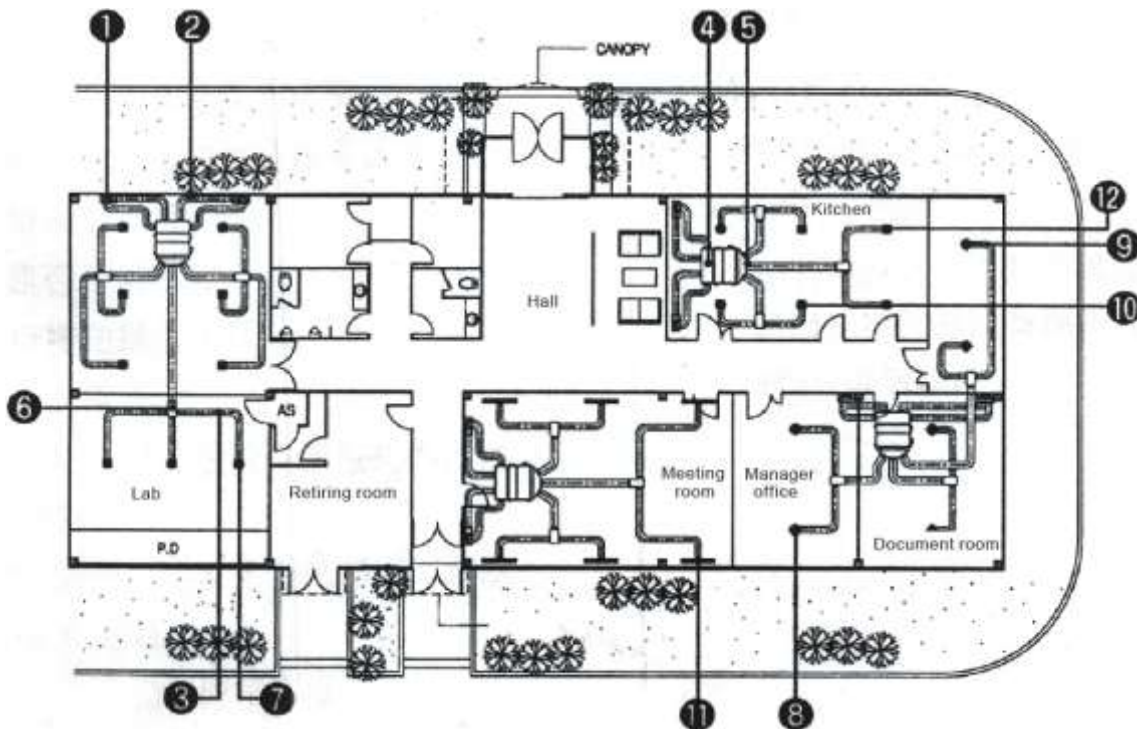





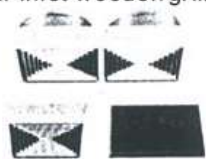



Construction and ventilation pipeline design scheme





Methods of configuring and selecting installation

Material name	Characteristics, advantages and other contents
1	1. Install the filter at the main body grille in case the store height is low, and at the main body of the indoor unit in case the store height is high.

	<p>Air inlet wooden grille</p>  <p>Filter</p>	<ol style="list-style-type: none"> 2. It cleans conveniently at the time of installing/uninstalling the filter. 3. The button structure is easy to install and uninstall.
2	<p>Hose (for absorbing noise)</p> 	<ol style="list-style-type: none"> 1. For purpose of air inlet. 2. Must adopt fire-resistant materials. 3. The heat insulation material must be glass wool.
3	<p>Hose (for general purpose)</p> 	<ol style="list-style-type: none"> 1. For purpose of air outlet. 2. Must adopt fire-resistant materials. (Those materials other materials. (Those materials other shall not be applied) 3. The heat insulation material must be glass wool.
4	<p>Air inlet noise pipe</p> 	<ol style="list-style-type: none"> 1. Install the unit at the air inlet so that the air flows smoothly and the noise is lower. 2. The noise value varies with the length. 3. The hose joint should be bent lest detachment of the pipe.
5	<p>Air outlet noise pipe</p> 	<ol style="list-style-type: none"> 1. Install the unit at the air outlet so that the air flows smoothly and the noise is lower. 2. The noise value varies with the length. 3. The hose joint should be bent lest detachment of the pipe.
6	<p>Distributor</p> 	<ol style="list-style-type: none"> 1. Install the unit at the air outlet so that the air flows smoothly and the noise is lower. 2. Select 1BY2 or 1BY3 according to the quantity of the diffusers. 3. The diffuser pipes should preferably have the same length after branching, and the minimum length of the ventilation pipes is 5m.

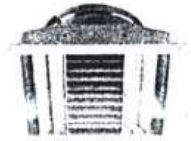
7	<p>Rectangular Air outlet</p> 	<ol style="list-style-type: none"> 1. Fixed model that diffuses air at a 360 angle. 2. The outline size should increase when the air volume is over 350CMH. (For above 303), i.e., when about 9 diffusers are required, the outline size should increase. 3. The diffuser pipes should preferably have the same length after branching, and the minimum length of the ventilation pipes is 5m.
8	<p>Air outlet</p> 	<ol style="list-style-type: none"> 1. Fixed model that diffuses air at a 360 angle. 2. The outline size should increase when the air volume is over 350CMH. (For above 303), i.e., when about 9 diffusers are required, the outline size should increase. 3. Proper air speed: For air speed of over 2-3.5m/s, select other diffusers (with great noise). 4. Install the diffuser pipe if it is necessary to install the model of over 3.5m/s. 5. For purpose of cooling-only model.
9	<p>Air outlet</p> 	<ol style="list-style-type: none"> 1 The lengthwise adjustable model which diffuses air at a 360 angle. 2. With the change of the cooling/heating air flow, the horizontal and vertical distance of the fan can be adjusted (applicable to department store and exhibition hall where the decorative effect is essential).
10	<p>Air outlet</p> <p>←Rectangular</p>  <p>Round→</p> 	<ol style="list-style-type: none"> 1. Low noise compared with other air outlets. Applicable to tall buildings that require along distance of air conditioning. 2. Select the ventilation pipe connection caliber according to the distance and the air speed. 3. Applicable to store height of over 5m (for design of tall store such as temple, consult manufacturer).
11	<p>Linear diffuser</p> 	<ol style="list-style-type: none"> 1. The fan is the adjustable type which can change direction of air flow. It is used for deluxe decoration. 2. The outline size should increase when the air flow is over 450CMH (3 or 4 SOLT) when about 6 diffusers are required, the outline size should increase. 3. If the proper air speed is 2.5-5m/s and actual air speed reaches over 5m/s, it is necessary to choose other diffusers (with higher noise values).

12	<p>Air outlet woodengrille</p> 	<ol style="list-style-type: none"> 1. Low noise compared with other air outlets. Applicable to tall buildings that require a long distance of air conditioning. 2. Select the ventilation pipe connection caliber according to the distance and the air speed. 3. Applicable to store height of over 5m (for design of tall stores such as temple, consult manufacturer).
Auxiliary materials	<p>Duct wrapping tape</p> 	<ol style="list-style-type: none"> 1. Flanges and pipelines connected to the ventilation pipes. 2. When the noise pipe is connected with the hose, the ventilation pipe tape must be applied (otherwise, with only adhesive tape, the adhesion will be weakened due to change of temperature).
	<p>Aluminium adhesive tape</p> 	<ol style="list-style-type: none"> 1. It is used to prevent glass wool leak and seal the gas at the time of the flanges and pipelines of the ventilation pipes. 2. Entwine for over 3 circles. 3. Use ventilation pipe-specific tapes (instead of ordinary adhesive tapes). <p>In order to ensure the installation quality and durability, it is necessary to use the auxiliary materials of standard specifications provided by manufacturer electronics and the auxiliary products of the specified manufacturers.</p>

9. Trial Run

- ✧ Please conduct in accordance with the nameplate of Trial Run Tenor on the electric control box.
- ✧ Perform the trial run only after the outdoor unit has been powered on for over 12 hours.
- ✧ Check whether all valves are opened before trial run.
- ✧ Check the electric safety before trial run.
- ✧ Do not perform compulsory operation in any way, because it is very dangerous if the protection device is not active.
- ✧ Perform trial run only after all installations are finished.
- ✧ Confirm the following issues before trial operation:
- ✧ Install the remote controller holder as required by the user. The holder must be installed in a location suitable for transmitting the signals of the remote controller to the indoor unit.

- ✧ Use the remote controller or wired controller to let the air conditioner run in the cooling mode. Inspect the following items according to the operation manual. If any fault occurs, remove the fault first.
- ✧ Check the indoor unit:
 - ✓ Whether any vibration or abnormal sound occurs during the operation.
 - ✓ Whether the air, noise and condensate generated by the unit affect the neighbors.
 - ✓ Whether any refrigerant is leaked.
 - ✓ Check whether the connective copper pipes and drain pipes generate condensate due to loose wrapping.
 - ✓ Open the air inlet grille of indoor unit to check whether any penetration or leak of water occurs, especially at the drain stopper.

10.Names and Functions of AC Components

Ducted indoor

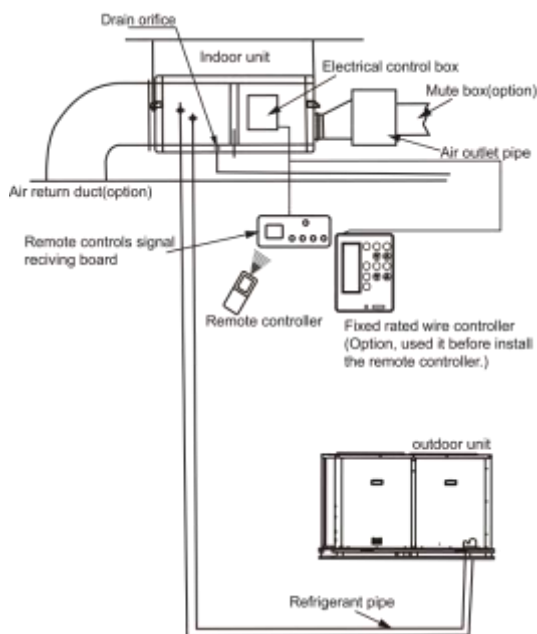

Floor standing indoor

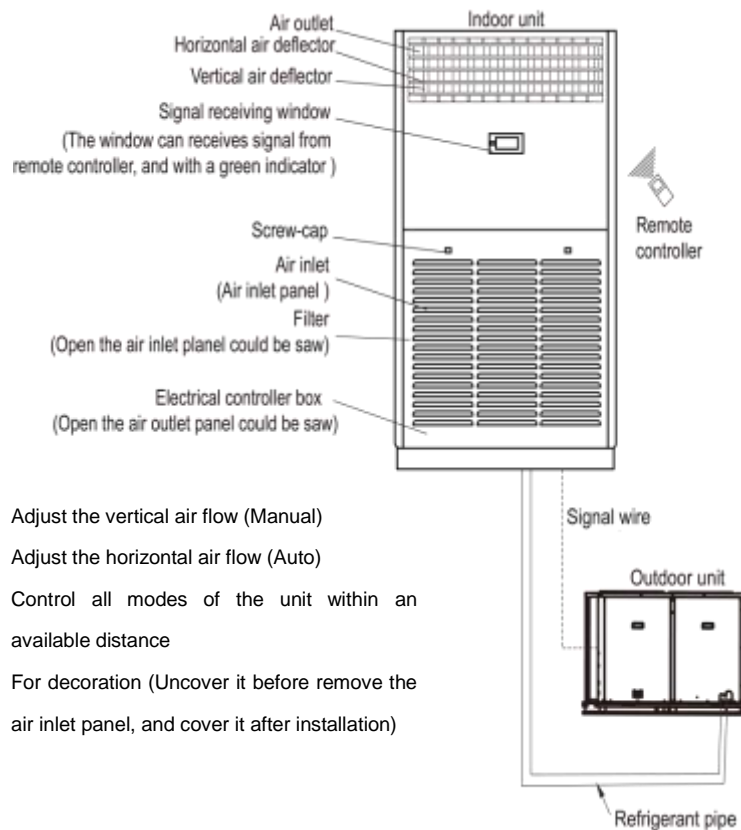

Horizontal air deflector	Adjust the vertical air flow (Manual)
Vertical air deflector	Adjust the horizontal air flow (Auto)
Remote controller	Control all modes of the unit within an available distance
Screw-cap	For decoration (Uncover it before remove the air inlet panel, and cover it after installation)

10.1 Control keys

✧ ON/OFF

This key controls air conditioner drive-up and shut down. Press the key at the first time, the unit will open, and then press it again the unit will shut down. During the unit is on serving the key is lighting; otherwise, the light will off.

✧ MODE

This key is for select the service mode. For cool-only unit, only air supply mode and cooling mode could be selected by this key; for heat pump unit, one more function—heating mode could be selected. You could press the key repeatedly for choose these modes. The selected mode is flashing in 2Hz. If you keep it without adjustment operation within 3 seconds, the system will confirm the mode.

✧ **Temperature adjustment key**

“Λ”key: For increase temperature. Any time you press the key, temperature will increase one Celsius degree. If you press the key last for more than 1 second, the temperature will increase by 1°C/sec, until which up to the maximum temperature 30°C(The buzzer will not buzz at this time.)

“V”key: For decrease temperature. Any time you press the key, temperature will decrease 1°C. When press the key last for more than 1 second, the temperature will decrease by 1°C per second, until which fall to the minimum 17°C. The buzzer will not buzz at this time.

✧ **Speed key**

For select air flow speed (low speed, medium speed, high speed and auto speed).

✧ **Swing key**

For select ON/OFF swing function.

✧ **Lock key**

Be used to select lock function on or off. This key is locate at the needle orifice of low right of the control panel, which be pressed by pin. If lock the unit by the key, any other keys is invalid, however the signal is effective.

10.2 Display icons

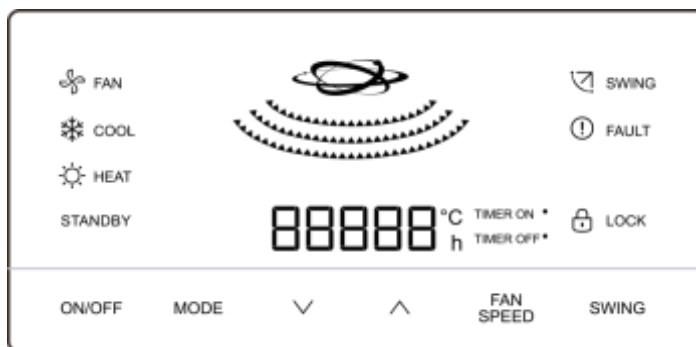



✧

It is named globe and always light-on.

✧ **'STANDBY**

The light is on when the system at standby status, and light-off when the unit switches on.

✧  **COOL**,  **HEAT**,  **Fan**

Press **MODE** key, the light of icon is on, the selected mode's icon will flash, after 3 seconds, the light extinction, while the status of selected mode icon is light-on instead of flashing. Power on for the first drive up, after press the **ON/OFF**, default mode of  **FAN** appear. If malfunction occur, **FAN** icon would always light-on, and  **FAULT** icon light up, fault codes is show. Modes only could be shifted at unit on.







✧ 

This is speed icon. Different speeds correspond to the waves below of Globe icon. The first wave means low wind, the middle wave means medium wind, and the last one stand for high wind, circulating point on these three waves means auto wind.

✧  **SWING**

Swing icon. Press the key of **SWING**, which icon is light-up, while close off this mode, the icon will light-off.

✧ 

For temperature display, the  shows temperature value, the unit is °C. For protection and error display, the first  display  (for protection) or  (for error), the last  display codes form  to .

In only air supply mode, no setting temperature is showed at .

✧  **Lock**

While locking, the lock icon is light-on; while unlocking, the lock icon is light-off.

11. Trouble shooting

11.1 Phenomena not attributable to faults of air conditioner

- ◇ The system does not run.
 - After pressing the **ON/OFF** button, the system does not run immediately.
 - If the **Run** indicator is on, it indicates the air conditioner runs in the normal status.
 - It does not run immediately because the safety device in the system is active to prevent overload.
 - Three minutes later, the air conditioner compressor will run automatically.
 - If the **Run** indicator and the **Defrost/Preheat** indicator are on, it indicates the heating mode is selected. At the beginning after startup, since the compressor does not run, the temperature of the indoor unit is too low.

- ◇ The indoor unit gives out white aerosol.
 - This phenomenon may occur when the indoor relative humidity is too high and the unit runs in the cooling mode.
 - The indoor unit is installed in a place where there is much oil mist or dust. If the internal stain of the indoor unit is heavy, the temperature in the room will be distributed unevenly. In the case, the interior of the indoor unit must be cleaned. The cleaning units must be performed by professional maintainers.
 - This phenomenon may also occur when the air conditioner shifts from defrosting operation to heating operation. That is because the moist generated by defrosting is expelled as steam.

- ◇ Noise of air conditioner
 - When the air conditioner runs in the cooling, dry or heating mode automatically, grave continuous sizzles may occur. That is the sounds of refrigerant flowing between the indoor unit and the outdoor unit. The sizzles may be heard shortly after the unit stops running or when the unit runs in the defrost mode. That is the sound raised because the

refrigerant stops flowing or changes to the volume of flow.

- Squeak may occur when the air conditioner starts or stops running. That is the sound raised because the plastic assemblies inflate or deflate when the temperature changes.

- ✧ Dust is blown out of the indoor unit.

When the air conditioner resumes service after a long period out of service, the dust in the indoor unit will be blown out.

- ✧ The indoor unit gives out smell.

The indoor unit absorbs the smell of the room, furniture or smoking, and gives it out when running.

- ✧ Shift from cooling mode to air supply mode.

- In order to prevent frosting of the indoor heat exchanger, the air conditioner shifts to air supply mode automatically, and resumes to cooling mode in a short time.
- When the room temperature decreases to the set temperature, the air conditioner will shut down the compressor automatically, and shifts to the air supply status. After the room temperature rises, the compressor will restart. The action of the compressor in the heating mode is the contrary.

11.2 Faults of air conditioner and cause

- ✧ If any of the following exceptions occur, operation of the air conditioner will be immediately stopped. Turn off the power switch, and check it.
 - The **Run** indicator blinks quickly (2 blinks per second.). After turning off the power switch and then turning it on again, that indicator still blinks quickly. The receiving function of the remote controller fails, or the start and shutdown operation is abnormal.
 - The fuse blows out frequently, or the circuit breaker protection occurs frequently.
 - Foreign substance or moist enters the air conditioner or other exceptions occur.
- ✧ If the air conditioner fails but does not meet the foregoing phenomena obviously, check the

system in the following procedure:

Symptom	Possible causes	Way of handing
The system does not run.	Power supply fails.	Operate it after power supply resumes and connect the power supply properly.
	The power switch is not connected.	
	The fuse blows out or the circuit breaker acts.	Replace the fuse or check whether electric leakage occurs.
	The remote controller or wired controller fails.	Check the remote controller or wired controller.

Symptom	Possible causes	Way of handing
The heating effect is poor.	The outdoor environment temperature is lower than -7°C .	Use a heating device. The unit cannot operate normally.
	The door or window is not closed tightly.	Close door and window tightly.
	The refrigerant is leaked or replenishment is deficient.	Detect leak, and fill the refrigerant of a correct quantity.

Symptom	Possible causes	Way of handing
The air conditioner sends air out but cannot provide cool air at all.	The setting temperature is improper.	The setting temperature is lower than the room's during the cooling status or higher during the heating status.
	3-minutes protection of the compressor.	Waiting for 3 minutes.

Symptom	Possible causes	Way of handing
The cooling effect is poor.	The condenser or evaporator is too dirty.	Clean the heat-exchanger.
	The filter is blocked.	Clean the filter.
	The intake orifice or exhaust orifice of the indoor and outdoor unit is blocked.	Remove foreign matters to keep well ventilated.
	The door or window is opened.	Close all the windows and doors.
	Directly exposed to sunlight.	Obstruct sunlight by curtains or jalousie.
	Too many heat sources.	Reduce heat sources.
	Too high outdoor environment temperature.	It is normal, and the cooling effect of the air conditioner is deteriorated.
	The refrigerant is leaked or the replenishment is deficient.	Detect leak, and fill the refrigerant of a correct quantity.

Symptom	Possible causes	Way of handing
The unit keep starting up and shutting down frequently.	The refrigerant is excessive or deficient.	Detect leak, and fill the refrigerant of a correct quantity.
	Air or non-condensable gas exists in the refrigerant loop.	Make a vacuum again and fill the refrigerant.
	The compressor fails.	Repair or replace the compressor.
	The voltage is too high or too low.	Install a voltage regulator.
	The refrigerant loop is obstructed.	Locate the causes and replace the part.

11.3 Faults of remote controller and cause

- ◇ The shift function cannot be set.

Symptom	Check item	Cause
The wind speed cannot be shifted.	Check whether the mode marked the screen of controller is AUTO .	When the auto mode is selected, the indoor fan speed will be in automatically running and cannot be adjusted.
	Check whether the mode marked on the controller screen is DRY .	When the dry mode is selected, the indoor unit will set fan speed automatically. The speed can selectable only in cooling, heating and fan mode.

- ◇ The transmitting symbol ▲ does not blink.

Symptom	Check item	Cause
Pressing ON/OFF button, the remote controller signal cannot be transmitted.	Check whether the batteries of remote controller are low.	When the batteries are exhausted, the signals cannot be transmitted.

- ◇ The temperature indicator does not light up.

Symptom	Check item	Cause
The temperature indicator does not light up.	Check whether the mode marked on the screen is FAN .	In the fan mode, the temperature cannot be set.

✧ The display disappears.

Symptom	Check item	Cause
After a while the ON/OFF display disappears.	Check whether the time set on the timer has expired.	The air conditioner stops running because the set time has expired.
After a while the TIMING ON display disappears.	Check whether the time set on the time has expired.	When it comes to the set time of starting operation of the air conditioner, the air conditioner will start running automatically, and the corresponding display will disappear.

✧ No sound of receiving signal.

Symptom	Check item	Cause
Pressing the ON/OFF button, the air conditioner does not raise the receiving tone.	When the ON/OFF button is pressed, check whether the signal transmitting part of the remote controller is aligned with the receiving part of the indoor unit.	Align the signal transmitting part of the remote controller with the receiving part of the indoor unit. Then press the ON/OFF button repeatedly.
	Check whether the power switch of the air conditioner is connected properly.	The air conditioner cannot receive the signals of the remote controller, because it is shut down.
The buttons of the remote controller do not work.	Check whether the lock icon is in the screen of the remote controller.	Lock the buttons.

11.4 Duct type indoor unit malfunction and protection codes

✧ Names of indicators in receiving kit

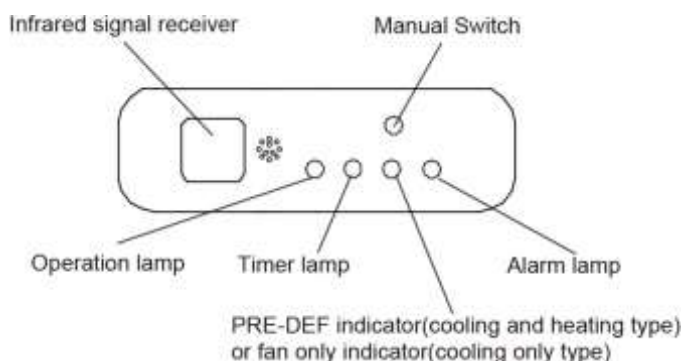

Display content	Fault or protection meaning
All lamps	Lack of neutral line.

flashing at 5Hz	
Timer lamp flashing at 5Hz	T1, room temperature sensor, fault of open circuit, short circuit.
Operation lamp flashing at 5Hz	T2, pipe temperature sensor, fault of open circuit, short circuit.
Defrosting lamp flashing at 5Hz	Condenser temperature sensor malfunction.
Alarm lamp flashing at 5Hz	Water-level checking malfunction. (Reserved)
Operation lamp and timer lamp flashing at 5Hz	EEprom malfunction

✓ **All lamps flashing at 5Hz**

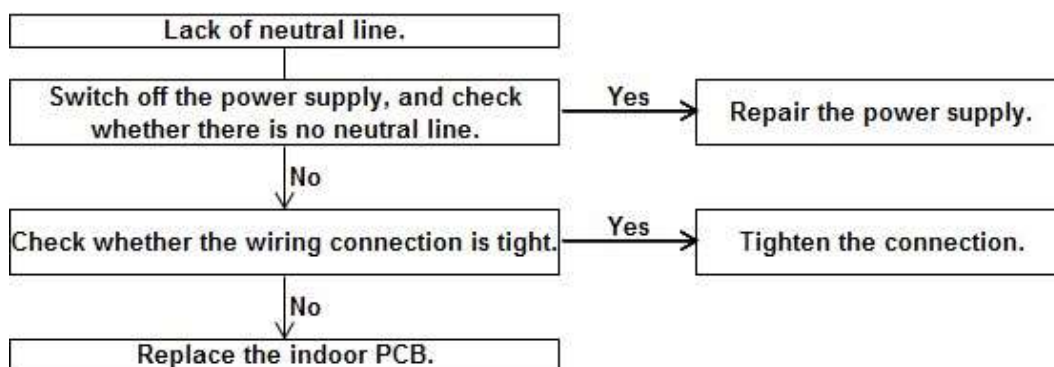

Timer lamp flashing at 5Hz, Operation lamp flashing at 5Hz

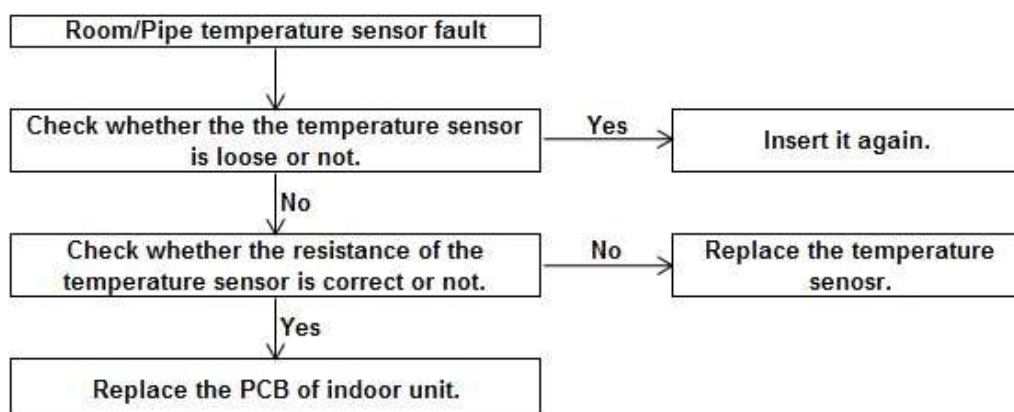

Defrosting lamp flashing at 5Hz

For these series products, if the condenser temperature sensor malfunction is displayed, it is

enough to check whether wiring has problem. If the wiring is correct, the PCB should be replaced.

Operation lamp and timer lamp flashing at 5Hz

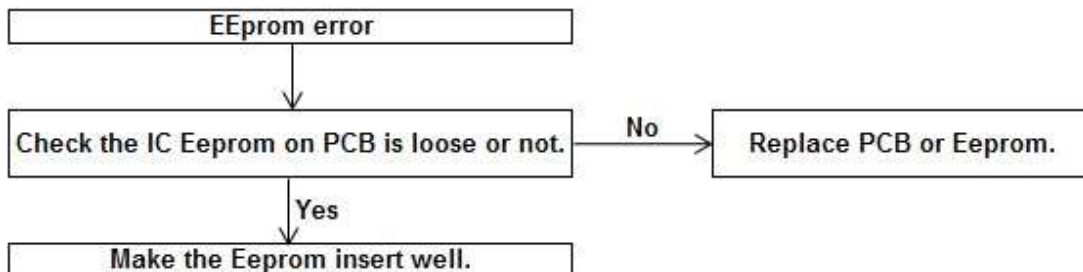

11.5 Floor standing type indoor unit malfunction and protection codes

LED display	Fault or protection meaning
E0	EEPROM malfunction
E1	T1, room temperature sensor, fault of open circuit, short circuit.
E2	T2, pipe temperature sensor, fault of open circuit, short circuit.
P1	Low temperature protection under cooling mode.
P2	High temperature protection under heating mode.

E0

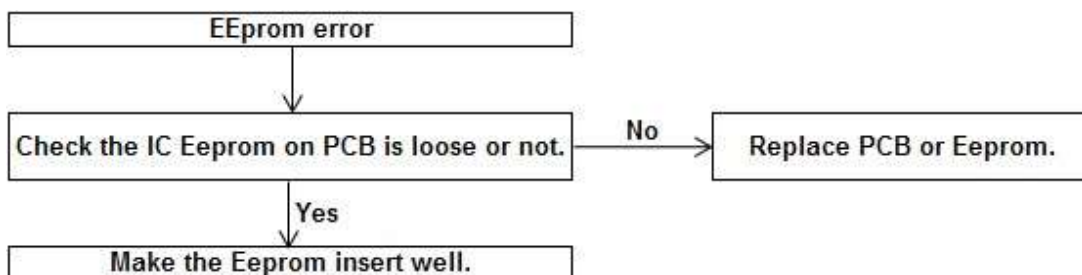

E1, E2

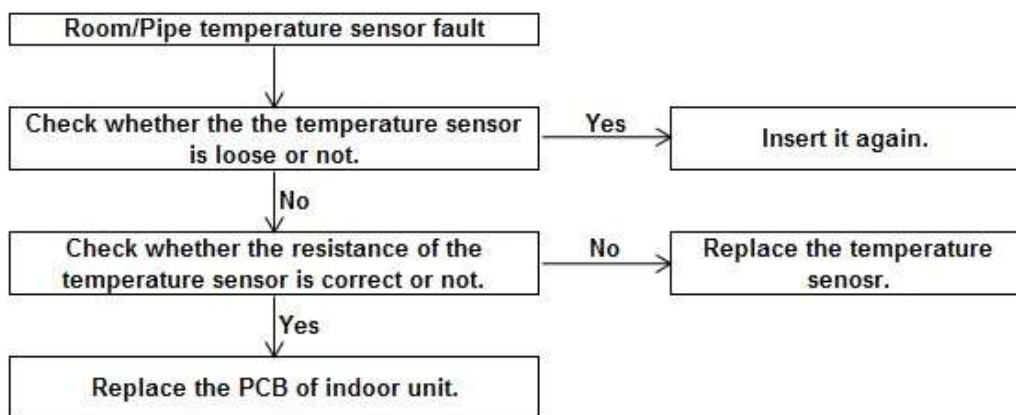

P1, P2

They are the normal protection. Under the cooling mode, when the pipe's temperature of evaporator is too low, the protection will be triggered to avoid ice covering the evaporator. Under the heating mode, once the pipe's temperature is too high, the P2 protection will be triggered.

11.6 Outdoor unit malfunction and protection codes

Type	LED1	LED2
Phase sequence or lack of phase.	●	☆★
Communication error.	●	☆☆★
Condenser temperature sensor error.	●	☆☆☆★
Ambient temperature sensor error	●	☆☆☆☆★
System low pressure protection.	○	☆★
Three times low pressure protections within 1 hour.	☆	☆★
System hi-pressure protection, hi-temperature protection of compressor discharger.	○	☆☆★
Current overload protection.	○	☆☆☆★
High temperature protection of condenser.	○	☆☆☆☆★

Note:

- : Light
- : Extinguishing
- ☆: Rapidly flash
- ★: Slowly flash

When the outdoor unit protections of temperature or system pressure are triggered three times within 1 hour, the unit will resume after power on again.

Phase sequence or lack of phase

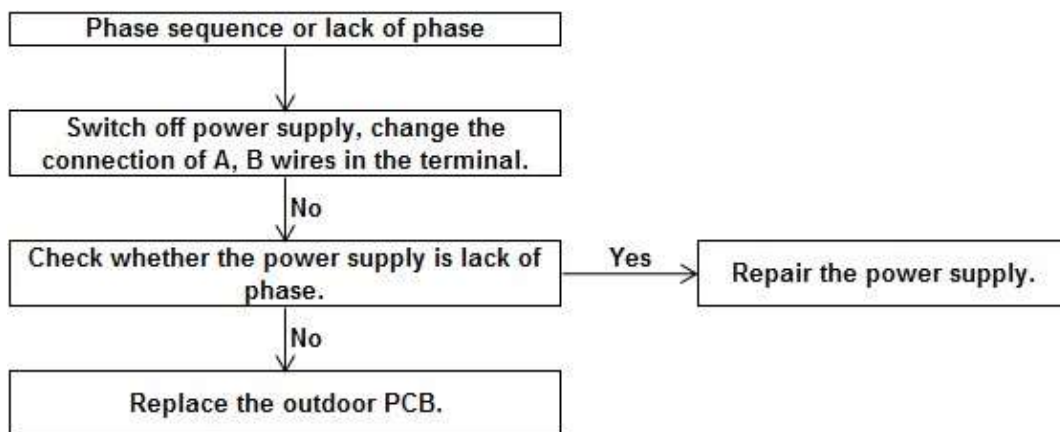

Communication error

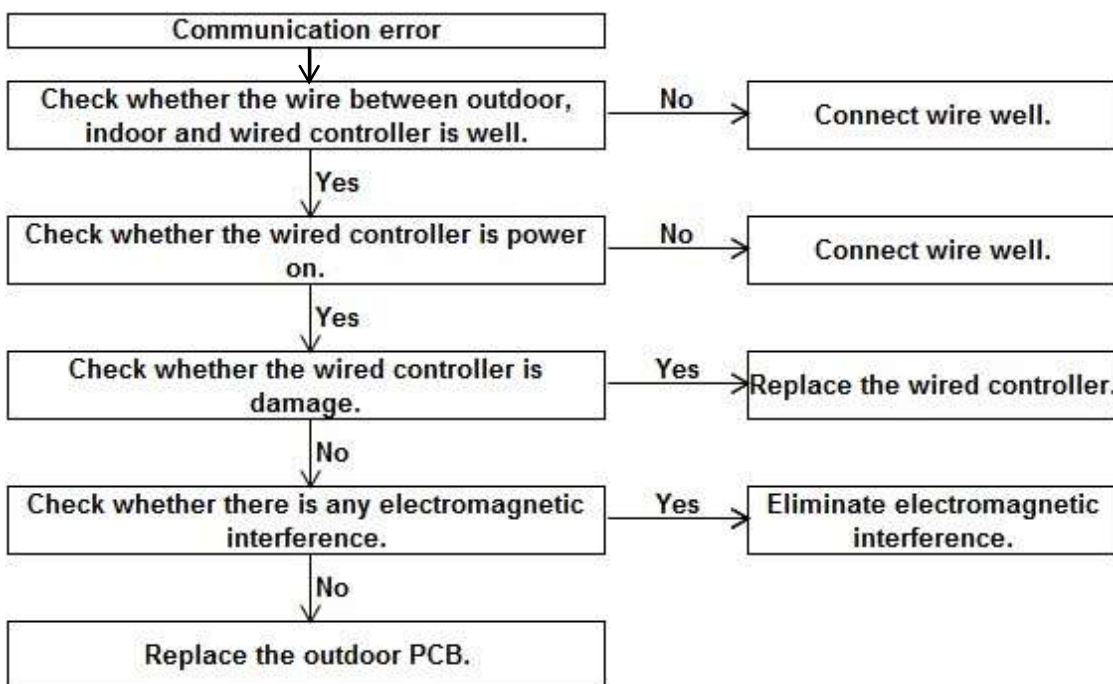

Condenser temperature sensor error

Ambient temperature sensor error

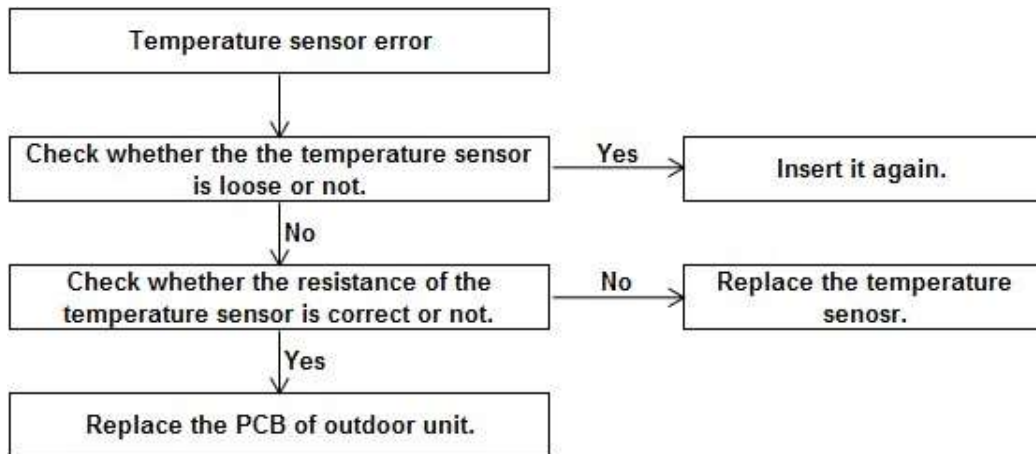

System low pressure protection

Three times low pressure protections within 1 hour

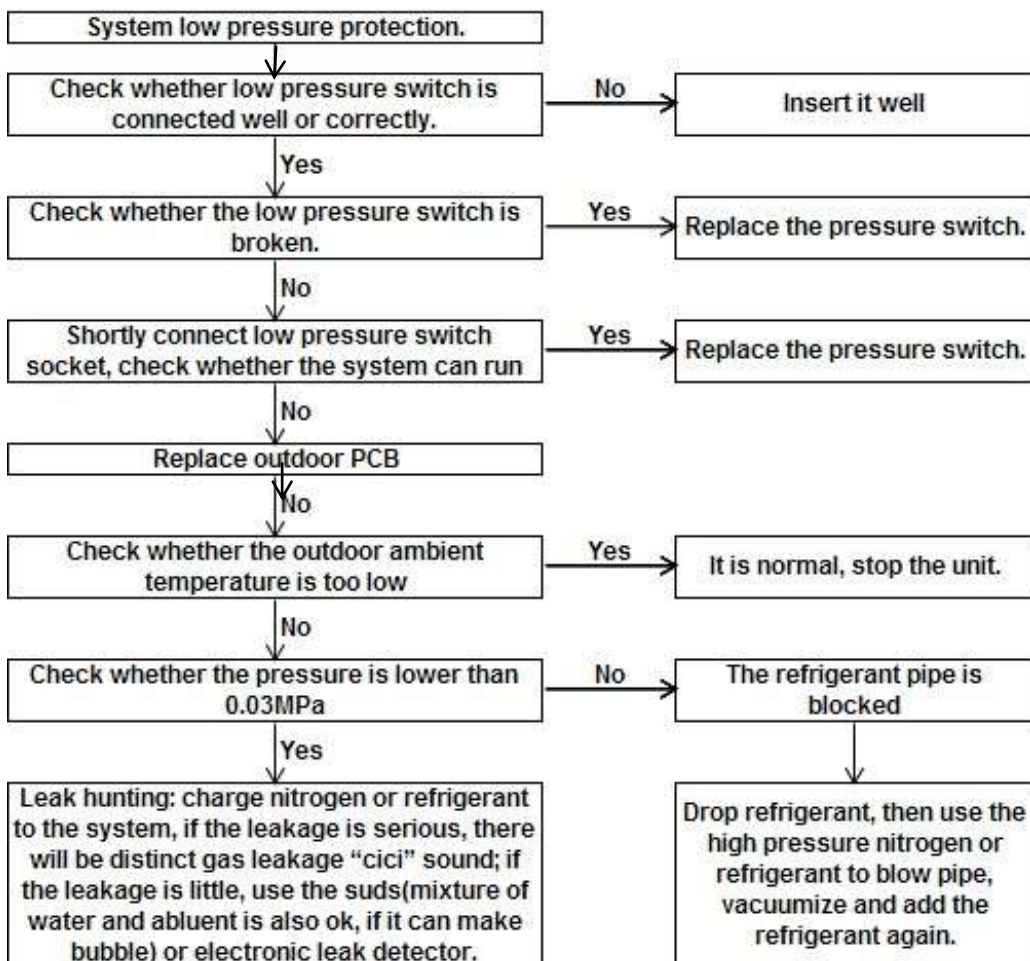

System high pressure protection

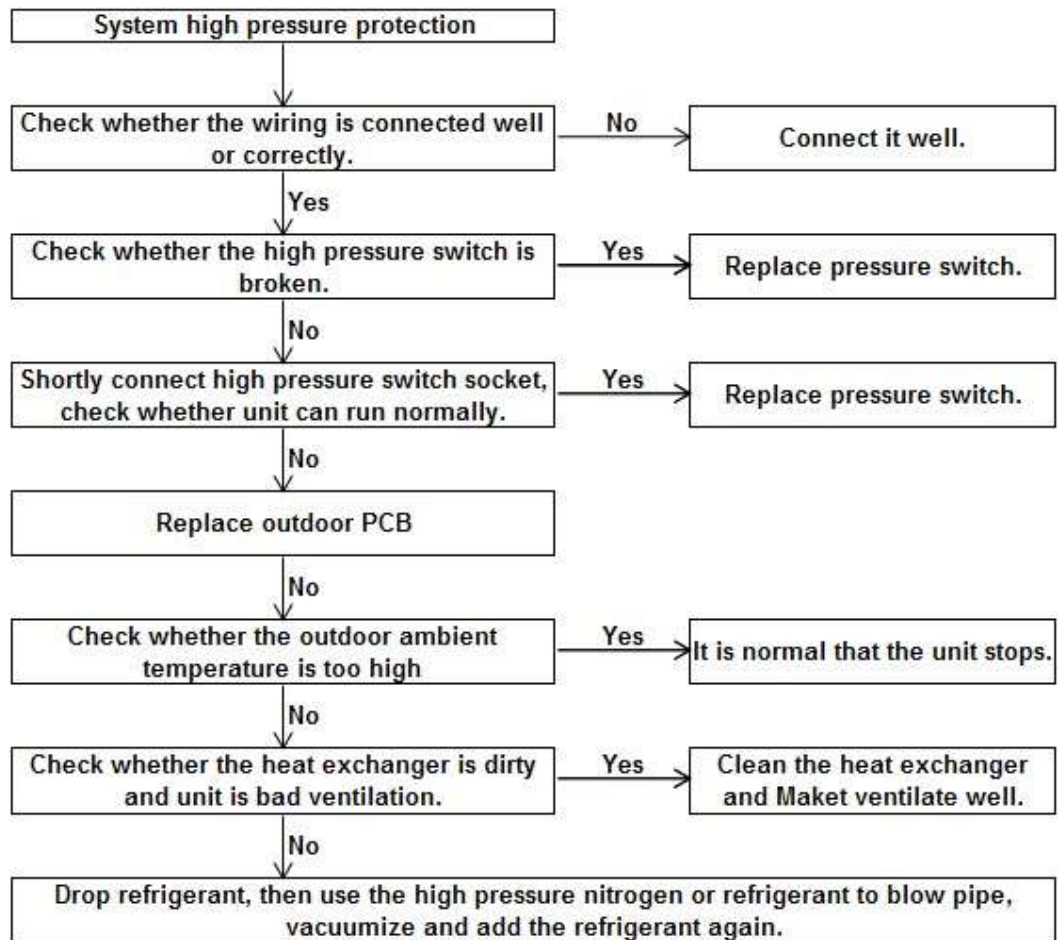

Hi-temperature protection of compressor discharger

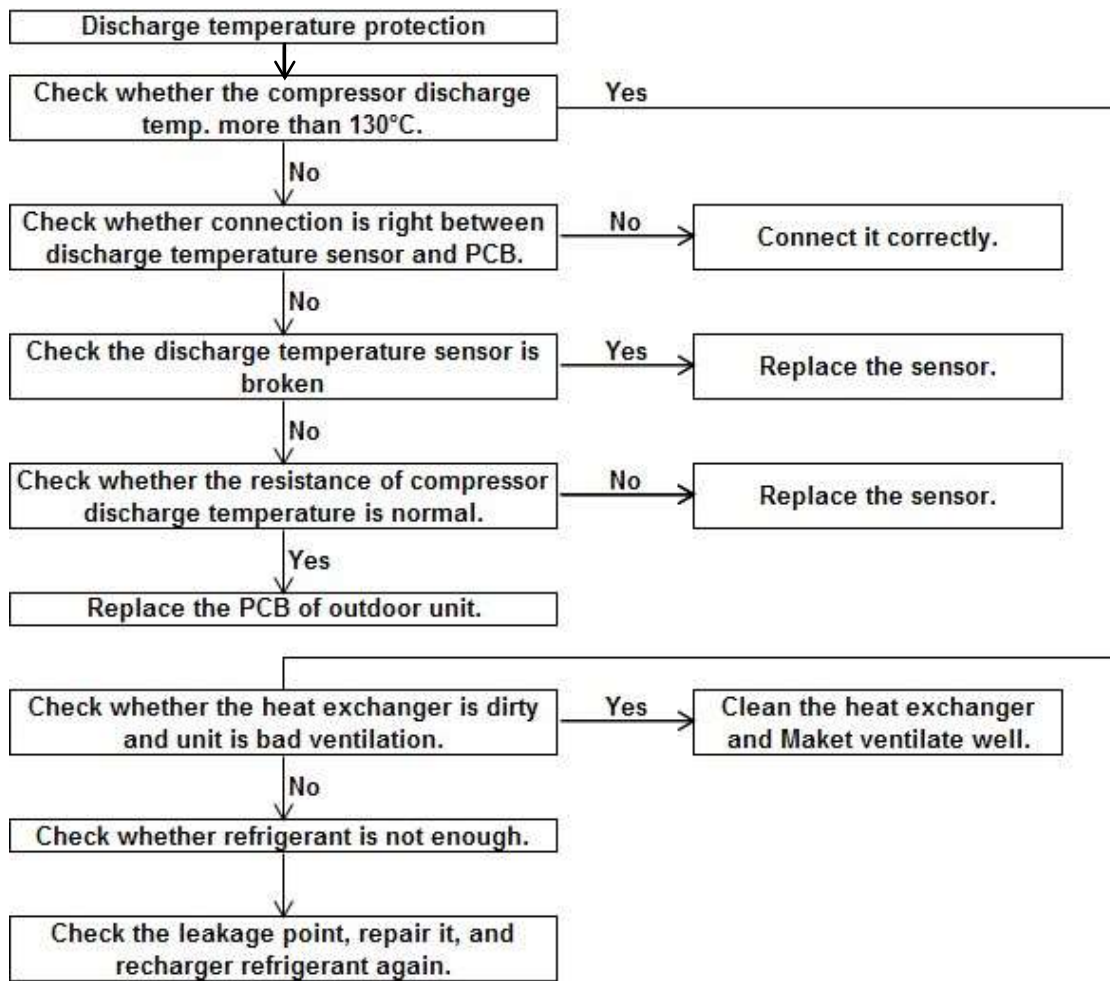

Current overload protection

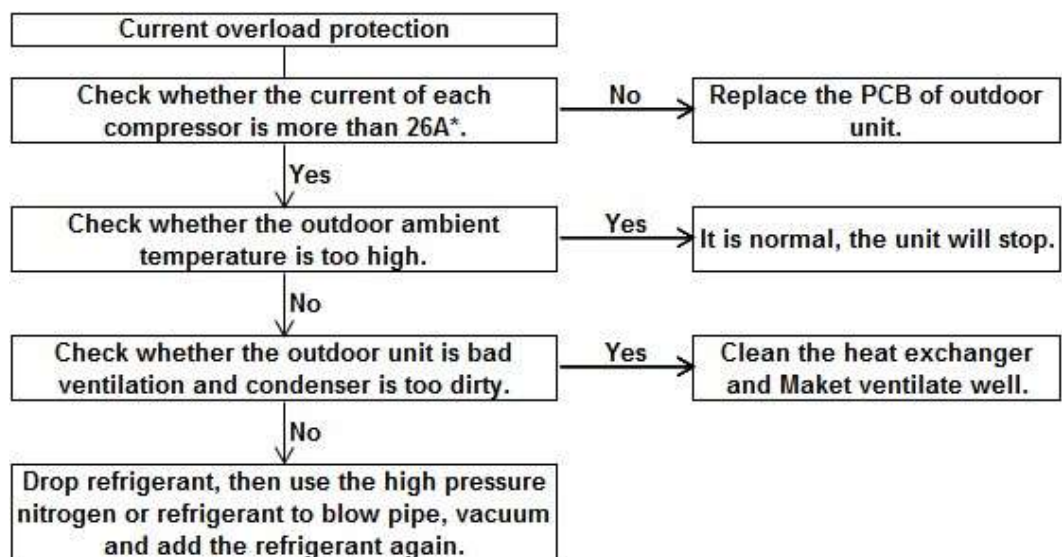

Note:

The value of current protection is 26A for 76000Btu/h outdoor unit, 28A for 96000Btu/h outdoor unit,

30A for 12000Btu/h outdoor unit, 26A for 15000Btu/h outdoor, 28A for 192000Btu/h outdoor unit.

High temperature protection of condenser

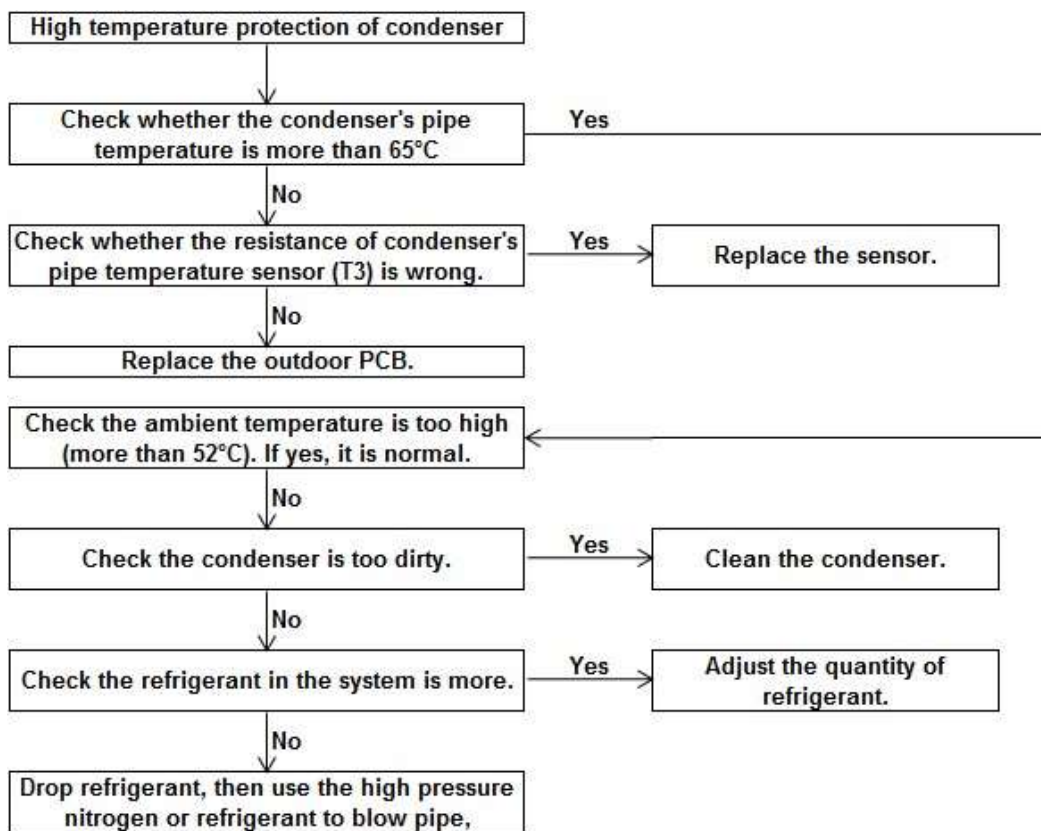

12. Maintenance

- ✧ Operation required before leaving the unit idle for a long period.
 - Let the air conditioner run in the fan mode for about half a day, and let its interior be fully dry.
 - Switch off the power by the button in remote controller, and then cut off the power supply.
 - When the main power switch is turned on, a certain extent of electric power is consumed even if the air conditioner does not run. Turning off the main power switch can save energy.
 - Remove the batteries out of the remote controller.
 - After the air conditioner has been in service for several seasons, foreign substance accumulates inside the unit to an extent dependent on the working conditions. Therefore, shut down the air conditioner through the **ON/OFF** button of the controller, and then cut off the power supply.

- ◇ Startup after a long period out of service.
 - Check the following issues:
 - Check whether the air inlet or outlet of the indoor unit and outdoor unit is blocked.
 - Remove foreign substance if any.
 - Check whether the ground wire is connected properly.
 - Check whether the condensate water is discharged normally.
 - Check whether the insulation work of refrigerant circuit and ventilating duct is on sound status.
 - Check whether the installing seat is corroded or rusted.
- ◇ Startup
 - Connect the indoor unit 12 hours after connect the outdoor unit to power supply.
 - Switch on the power control of remote controller or wired controller, and then startup the air conditioning.
- ◇ Maintenance and upkeep of outdoor unit
 - The edge of some sheet metal assemblies and the fin of the condenser are very sharp. Incorrect operation may cause harm. Be cautious when cleaning them up.
 - Check the air inlet and outlet of the outdoor unit periodically to see whether they are blocked by stain or lampblack.

Maintenance of indoor unit

- ◇ Only the professionals can perform repair. Before maintain the unit, turn off the main power switch. Do not use water or air with a temperature higher than 50°C to clean the panel.
- ◇ Check and maintain the ventilating slot once every half years, wash and maintain with corresponding disinfection shall process once.
- ◇ Every two years are recommended. The filter can expel dust and other particles in the air. If it is blocked, the effect of the air conditioner will be degraded. Therefore, clean it every another two weeks if the air conditioner already has been used for a long period. If the indoor unit is installed in a place with heavy dust, clean the filter more often.
- ◇ If the stain is heavy and difficult to clean, replace the filter.
- ◇ Do not replace the power cable without permission. If the power cable is damaged, specialized power cable must be used as substitute.

Part. 6 Controller

1. Wireless Remote Controller (Standard for floor-standing) 97
2. Wired Controller: WR-29B-CM (Standard for duct) 112
3. Centralized Controller: CRF-10-CM (Optional)..... 124

1. Wireless Remote Controller (Standard for floor-standing)

1.1 Remote controller specifications

Model	CARR-R51/E
Rated Voltage	3.0V
Lowest Voltage of CPU Emitting Signal	2.0V
Reaching Distance	8m (when using 3.0 voltage, it Gets 11m)
Environment Temperature Range	-5°C~60°C

Performance Features

1. Operating Mode: Cooling, Heating, Dry, Fan and Auto.
2. Timer Setting Function in 24 hours.
3. Indoor Setting Temperature Range: 17°C ~30°C.
4. LCD (Liquid Crystal Display) of all functions.
5. Night Light Function (Optional).

1.2 Introduction of function buttons on the remote controller

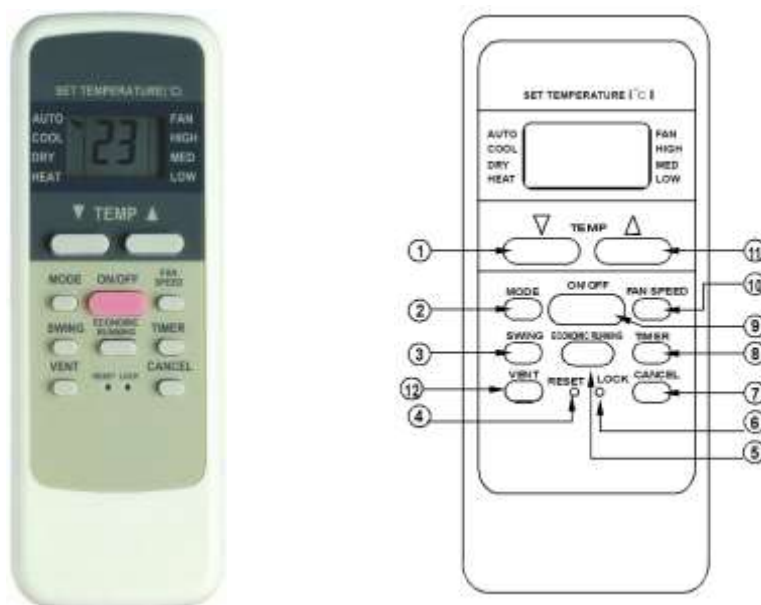

Notes:

This illustration is for explanation purposes only. The actual shape or button names of the remote controller may be slightly different.

1. **TEMP** Button: Push the **TEMP** button to decrease the indoor temperature setting or to adjust the **TIMER** in a counter-clockwise direction.

2. MODE Select Button: Each time you push the button, a mode is selected in a sequence that goes from AUTO, COOL, DRY, HEAT and FAN as the following figure indicates:

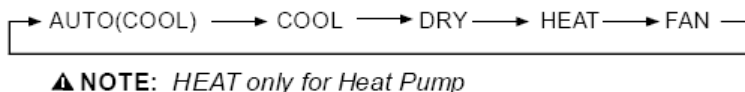

- 3. SWING** Button: Push this switch button to change the louver angle.
- 4. RESET** Button: When the **RESET** button is pushed, all of the current settings are cancelled and the control will return to the initial settings.
- 5. ECONOMIC RUNNING** Button: Push this button to go into the Energy-Saving operation mode.
- 6. LOCK** Button: Push this button to lock in all the current settings. To release settings, push again.
- 7. CANCEL** Button: Push this button to cancel the **TIMER** settings.
- 8. TIMER** Button: This button is used to preset the time ON (start to operate) and the time OFF (turn off the operation).
- 9. ON/OFF** Button: Push this button to start the unit operation. Push the button again to stop the unit operation.
- 10. FAN SPEED** Button: This button is used for setting Fan Speed in the sequence that goes from AUTO, LOW, MED to HIGH, then back to AUTO.
- 11. TEMP** Button: Push the button to increase the indoor temperature setting or to adjust the **TIMER** in a clockwise direction.
- 12. VENT** Button: Push this button to set the ventilating mode. The ventilating mode will operate in the following sequence:

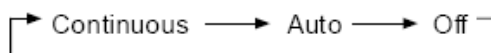

Notes: Ventilation function is available for the fresh air series.

1.3 Names and functions of indicators on remote controller

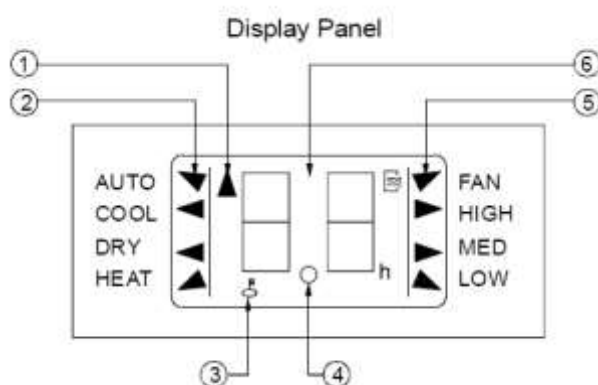

① **TRANSMISSION Indicator:** This indicator lights when remote controller transmits signals to indoor unit.

② **MODE Display:** Show the current operation modes-- AUTO, COOL, DRY and HEAT. HEAT is only available for heat pump model.

③ **LOCK display:** To displayed by pushing the **LOCK** button. Push the **LOCK** button again to clear display.

④ **TIMER Display:** This display area shows the settings of TIMER.

That is, if only the starting time of operation is set, it will display the **TIMER ON**. If only the turning off time of operation is set, it will display the **TIMER OFF**. If both operations are set, it will show **TIMER ON** and **TIMER OFF** which indicates you have chosen to set both the starting time and off time.

⑤ **FAN Display:** When push the **FAN** button, this indicator lights.

⑥ **Digital Display Area:** This area will show the temperature and, if in the TIMER mode, will show the ON and OFF settings of the TIMER.

Notes:

All items are shown in the previous picture for the purpose of clear presentation but during the actual operation only the relative functional items are shown on the display panel.

1.4 Operating the remote controller

1) Install / Replace Batteries

The Remote Controller uses two alkaline dry batteries (R03/Ir03X2).

- ※ To install batteries, slide back the cover of the battery compartment and install the batteries according to the directions (+and -) shown on the Remote Controller.
- ※ To replace the old batteries, use the same method as mentioned above.

Notes:

1. When replacing batteries do not use old batteries or a different type battery. This may cause the remote controller to malfunction.
2. If you do not use the remote controller for several weeks remove the batteries. Otherwise battery leakage may damage the remote controller.
3. The average battery life under normal use is about 6 months.
4. Replace the batteries when there is no answering beep from the indoor unit or if the Transmission Indicator light fails to appear.

2) Automatic Operation

When the Air Conditioner is ready for use, switch on the power and the **OPERATION** indicator lamp on the display panel of the indoor unit starts flashing.

- ※ Use the **MODE** select button to select AUTO. In the multi system, to avoid mode conflict; auto-mode is taken as cool mode.
- ※ Push the **TEMP** button to set the desired room temperature.
- ※ The most comfortable temperature settings are between 21°C and 28°C
- ※ Push the **ON/OFF** button to start the air conditioner. The **OPERATION** lamp on the display panel of the indoor unit lights. The operating mode of AUTO FAN SPEED is automatically set and there are no indicators shown on the display panel of the remote controller.
- ※ Push the **ON/OFF** button again to stop the unit operation.

Notes:

1. In the AUTO mode, the air conditioner can logically choose the mode of COOL, FAN, HEAT and DRY by sensing the difference between the actual ambient room temperature and the set temperature on the remote controller.
2. If the AUTO mode is not comfortable for you, the desired mode can be selected manually.

3) COOL, HEAT, and FAN ONLY Operation

- ※ If the AUTO mode is not comfortable, you may manually change the settings by using COOL, DRY, HEAT (HEAT PUMP units only), or FAN ONLY modes.
- ※ Push the **TEMP** button to set the desired room temperature.
- ※ When in COOLING mode, the most comfortable settings are 21°C or above. When in

HEATING mode, the most comfortable settings are 28°C or below.

- ※ Push the **FAN SPEED** to select the FAN mode of AUTO, HIGH, MED or LOW.
- ※ Push the **ON/OFF** button. The operation lamp lights and the air conditioner start to operate per your settings. Push the **ON/OFF** button again to stop this unit operation.

Notes:

The FAN ONLY mode cannot be used to control the temperature. While in this mode, only steps 1, 3 and 4 may be performed.

4) DRY Operation

- ※ Push the **MODE** button to select DRY.
- ※ Push the **TEMP** button to set the desired temperature from 21°C to 28°C.
- ※ Push the **ON/OFF** button. The operation lamp lights and the air conditioner start to operate in the DRY mode. Push the **ON/OFF** button again to stop this unit operation.

Notes:

Due to the difference of the set temperature of the unit and the actual indoor temperature, the Air Conditioner when in DRY mode will automatically operate many times without running the COOL and FAN mode.

5) TIMER Operation

Push **TIMER** button to set the unit what time turn on or off.

a. To set the STARTING time.

- ※ Push the **CANCEL** button to cancel any former settings.
- ※ Push the **TIMER** button. The remote controller will show the **TIMER** and the signal "h" is shown on the display panel. The control is now ready to reset the **TIMER ON** to start the operation.
- ※ Push the **TEMP** button (▲ or ▼) to set desired unit **START** time.
- ※ After setting the **TIMER** there will be a one-half second delay before the remote controller transmits the signal to the Air Conditioner. Then, after approximately another 2 seconds, the set temperature will re-appear on the digital display.

b. To set the STOPPING time.

- ※ Press the **CANCEL** button to cancel any former settings.

- ※ Push the **TIMER** button and the remote controller will show the last set time for the START operation and the signal "**h**" will be shown on the display panel. You are now ready to readjust the TIMER OFF to stop the operation.
- ※ Push the **TEMP** button to cancel the TIMER ON setting. The digital area will show "**00**".
- ※ Push the **TIMER** button and the remote controller will show the last set time for the STOP operation and the signal "**h**" will be shown on the display panel. You are now ready to reset the time of the STOP operation.
- ※ Push the **TEMP** button (**▲** or **▼**) to set the time you want to stop the operation.
- ※ After setting the TIMER there will be a one-half second delay before the remote controller transmits the signals to the Air Conditioner. Then after approximately another 2 seconds, the set temperature will re-appear on the digital display.

c. Set the STARTING & STOPPING time

- ※ Press the **CANCEL** button to cancel any former settings.
- ※ Push the **TIMER** button and the remote controller will show the last set time for START operation and the signal "**h**" will be shown on the display panel. You are now ready to readjust the TIMER ON to start the operation.
- ※ Push the **TEMP** button (**▲** or **▼**) to set the time you want to start the operation.
- ※ Push the **TIMER** button and the remote controller will show the last set time for STOP operation and the signal "**h**" will be shown on the display panel. You are now ready to reset the time of the STOP operation.
- ※ Push the **TEMP** button (**▲** or **▼**) to set the time you want to stop the operation.
- ※ After setting the TIMER there will be a one-half second delay before the remote controller transmits the signal to the Air Conditioner. Then, after approximately another 2 seconds, the set temperature will re-appear on the digital display.

Notes:

- 1. Please reset the TIMER after cancelling the former time settings.**
- 2. The setting time is relative time. That is the time set is based on the delay of the current time.**

Warning

- 1. Be sure there are no barriers between the remote controller and the receiver of indoor unit otherwise the air conditioner will not work.**

2. Keep the Remote Controller away any liquids.
3. Protect the Remote Controller from high temperatures and exposure to radiation.
4. Keep the indoor receiver out of direct sunlight or the air conditioner may malfunction.
5. Keep controller away from EMI (Electro-Magnetic Interference) supplied by other household appliances.

2. Wired Controller: WR-29B-CM (Standard for duct)



WR-29B-CM

2.1 Wired controller specifications

Model	WR-29B-CM
Power Supply Voltage	5.0V DC
Ambient Temperature Range	-15°C~43°C
Ambient Humidity Range	RH40%~RH90%

Performance Features

1. Operating mode: Cool, heat, dry, fan and auto.
2. Set the mode through buttons.
3. Indoor setting temperature range: 17°C ~30°C.
4. LCD (Liquid Crystal Display).
5. Night light and follow me function
6. Remote receiving function.

2.2 Wired controller outlook



2.3 Operation instructions

1) Remote signal receiving function:



the wired controller can be a remote signal receiving device, it is possible to use the wireless remote controller to control the air conditioner through the wired controller when the system have been powered on.

Notes: The wired controller will not receive the swing controlling instruction. For the indoor unit with swinging function, you can directly use the wireless remote controller to control swinging through the display panel of the indoor unit, or use the swing button on the wired remote controller to control the indoor unit for swinging.

2) On and off the air conditioner:

Press the  On/Off button to control the indoor unit on and off status.

When the unit is turned off, press the  On/Off button, the unit will be turned on and the operating icon  lights up.

When the unit is turned on, press the  On/Off button, the unit will be turned off the operating icon  lights off.

3) Set the operating mode

Press the mode button  to set the operating mode, after each button press the operating mode will circle as follow:



Notes: When the controller has been set to cool only, then there is no HEAT mode.

4) Fan speed setting

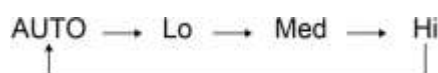

Under COOL, HEAT and FAN modes, press the fan speed button  can adjust the fan speed setting.

After each fan speed button press will circle as follow:





Notes: Under AUTO and DRY modes the fan speed is not adjustable and the default fan speed is auto.







5) Temperature setting

Under AUTO, COOL, DRY, HEAT modes, press the temperature setting buttons  and  to set the temperature, the adjusting range is 17°C~30 °C (or 62 °F~88 °F).



Notes: The setting temperature cannot be adjusted under fan mode.

6) Timer on and timer off setting

Press the timer/clock setting button , then enter into the timer on setting status, and screen will display  and .

Press the buttons  and  to adjust the timer. If the timer setting is less than 10 hours, each press  or  will increase or decrease 0.5 hour. When the timer setting is more than 10 hours, each press  or  will increase or decrease 1 hour, the maximum timer setting is 24 hours.

After finish adjusting the timer on setting, press the button  or wait for 5 seconds to confirm and exit the timer on setting.

Under the timer on setting status, press the timer/clock setting button , then enter into the timer off setting status, and the screen will display  and **0-0h**.



The setting method of timer off is the same as the timer on.





Under timer setting state, set the timer on and the timer off to be 0.0h can cancel timer on and time off.

Notes: If the wired controller has been set timer on/off, press the ON/OFF to turn on or turn off the unit then the timer will be canceled simultaneously.

7) Clock setting

Press the timer/clock button  setting for 3 seconds, and then enter into the clock setting status.

The hour position of the clock will flash, and can press  and  to adjust the hour value.

After finishing the hour setting, press left button  or right button  to switch to minute position setting, then the minute position will flash, press  and  to adjust the minute value.

After finish the clock setting, press the  button or wait for 5 seconds to confirm and exit the setting state.

8) Quiet operation



Under COOL, HEAT, FAN modes, press the  button to set into the quiet operation, it is used to reduce the running noise through setting the fan speed to low.

Notes: Under AUTO, DRY mode, the fan speed is auto and the  button does not work.

9) Lock the wired controller

Press the temperature adjusting buttons  and  simultaneously, the wired controller enters into locking state, and the locking icon  will be lighted up.

Under the locking state, the wired controller will not respond to the buttons pressing and the control instruction from the wireless remote controller.

Simultaneously press the temperature adjusting buttons  and  again can cancel the locking state.



10) Air filter cleaning reminding function

The wired controller records the total running time of the indoor unit, when the accumulated running time reaches the pre-set value, the air filter cleaning reminding icon  will be lighted up, to remind that the air filter of the indoor unit need to be cleaned.

Press  for 3 seconds, and reset the reminding icon and the wired controller will re-accumulate the total running time of the indoor unit.

Notes: The default setting value of the reminding function is 2,500 hours, and it can change to be 5,000 hours or 10,000 hours. The setting methods refer to the part of wired controller initial parameter setting.

11) Swing function

If the indoor unit supports swing function, press the right button  to adjust the air outlet direction of the indoor unit. Press this button for 3 seconds can turn on or turn off the auto swing function, the swing icon  will be lighted up when the auto swing function is turned on.

12) Follow-me function

When the system is running and the operating mode is AUTO, COOL or HEAT, press the  button will activate the follow-me function; press this button again to deactivate the function. Operating mode changeover will deactivate the function as well.

When the follow-me function is activated, the icon  will be light up, the wired controller will display room temperature read from local sensor, and transmit the temperature value to the indoor unit every 3 minutes.

2.4 Installation of wired controller

1) Safety precaution

- ✓ Stated below are important safety issues that must be obeyed. Confirm there is no abnormal phenomena during test operation after complete.
- ✓ Installation by other persons may lead to imperfect installation, electric shock or fire. Improper installation may lead to electric shock or fire. A random disassembly may cause abnormal operation or heating, which may result in fire.
- ✓ Do not install the controller in a place vulnerable to leakage of flammable gases. Once flammable gases are leaked and left around the wired controller, fire may occur.
- ✓ The wiring should adapt to the wired controller current. Otherwise, electric leakage or heating may occur and result in fire. The specified cables shall be applied in the wiring. No external force may be applied to the terminal. Otherwise, wire cut and heating may occur and result in fire.
- ✓ Don't place the wired controller near the lamps, to avoid the remote signal of the controller to be disturbed. Do not install the unit and controller in a place with much oil, steam, sulfide gas. Otherwise, the product may deform and fail.

2) Accessories

Name	Qty	Remarks
Wired controller	1	\
Cross round head wood mounting screw	3	M4×20 (For mounting on the wall.)
Cross round head mounting screw	2	M4×25 (For mounting on the electrical switch box.)
Installation manual	1	\
Owner's manual	1	\
Plastic expansion pipe	3	For mounting on the wall
Plastic screw bar	2	For fixing on the 86 electrician box.
Switching wires for signal receiving board	1	For connecting the signal receiving board and 4-core shield wire.
Switching wires for wired controller	1	(If needed) For connecting the main control panel

signal		and 4-core shielding wire.
--------	--	----------------------------

3) Supplied assemblies on the site

Name	Qty (Embedded into wall)	Specification (Only for reference)	Remarks
4-core shielded cable	1	0.5mm ² x4	The longest is 15m.
86 Electrician box	1	\	\
Wiring tube (Insulating sleeve and tightening screw.)	1	\	\

4) Installation procedure

- ✓ The installation manual contains information about the procedure of installing wired controller. Please refer to indoor unit installation manual for connecting between wired controller and indoor unit.
- ✓ Circuit of wired controller is low voltage circuit. Never connect it with a standard 220V or 380V circuit or put it into a same wiring tube with the circuit.
- ✓ The shield cable must be connected stable to the ground, or transmission may fail.
- ✓ Don not attempt to extend the shield cable by cutting, if it is necessary, use terminal connection block to connect.
- ✓ After finishing connection, do not use mugger to have the insulation check to the signal wire.
- ✓ Wired remote controller structure size figure (Unit: mm):

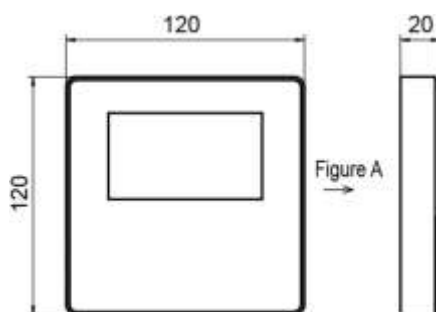

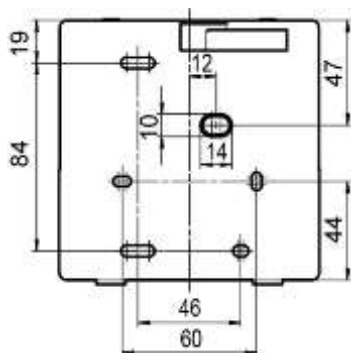

Rear view

✓ Wiring principle sketch:

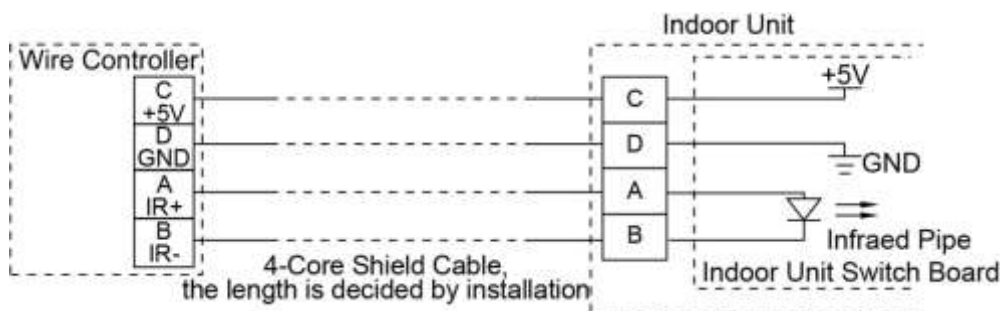

✓ Wiring figure:

Connect two terminals of embedded 4-core shielding wire with the switching wires of wired controller and signal receiving board. Make sure the sequence of 4 terminals (A, B, C and D) should correspond to the wire sequence of signal switching wires (A, B, C and D).

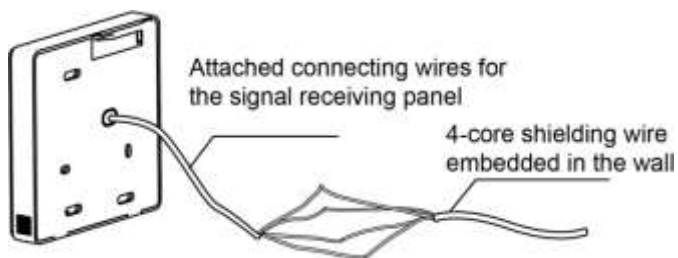

If the embedded 4-core shielding wire cannot go through the wired controller, it can use signal switching for connection, make sure the wires are reliable and firm.

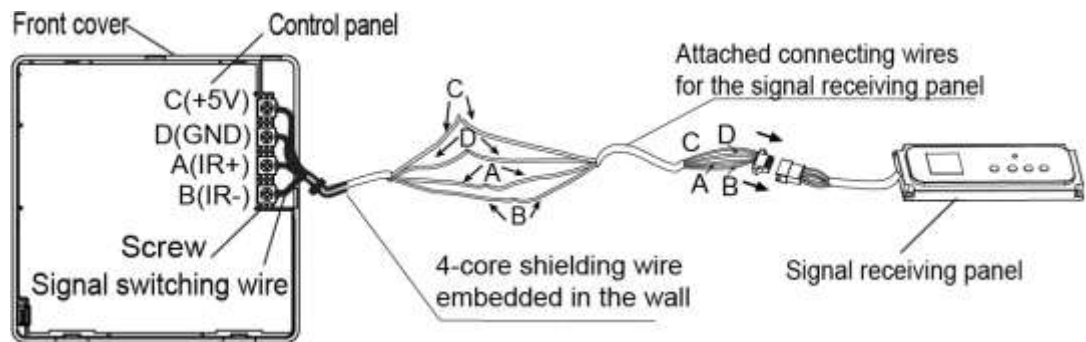

The tightening torque range of screw is: 0.8~1.2N·m (8~12kgf·cm).

✓ Wired controller back cover installation

Use straight head screwdriver to insert into the buckling position in the bottom of wired controller, and spin the screwdriver to take down the back cover. Pay attention to spinning direction, otherwise will damage the back cover.

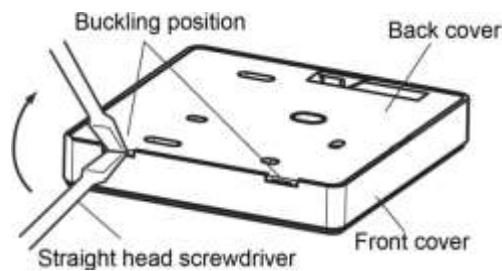

Use three M4×20 screws to directly install the back cover on the wall.

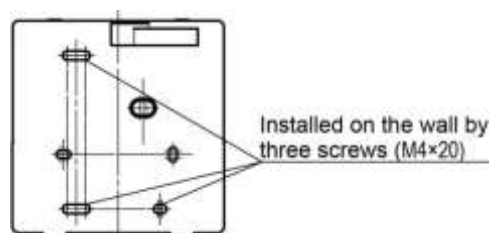

Use two M4×25 screws to install the back cover on the 86 electrician box, and use one M4×20 screws for fixing on the wall.

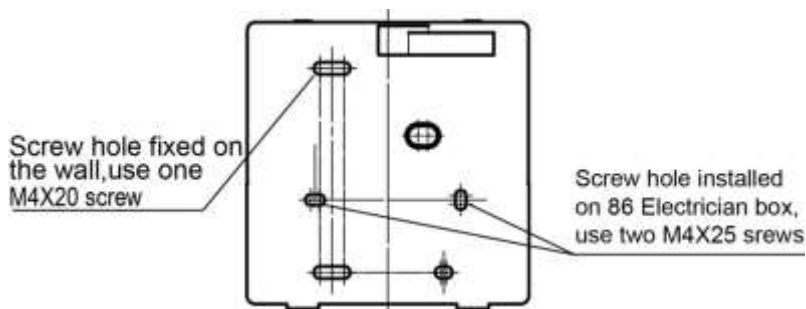

Adjust the length of two plastic screw bars in the accessory to be standard length from the electrical box screw bar to the wall. Make sure when install the screw bar to the electric box screw bar, make it as flat as the wall.

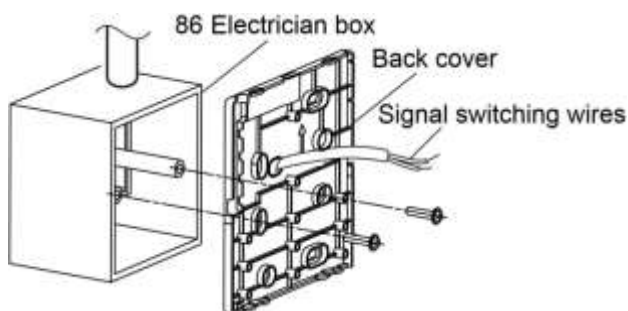

Use cross head screws to fix the wired controller bottom cover in the electrical box through the screw bar. Make sure the wired controller bottom cover is on the same level after installation, and then install the wired controller back to the bottom cover.

Over fasten the screw will lead to deformation of back cover.

- ✓ Neaten the wires of the wired controller

There are three positions of signal wire outlet around the wired controller, when the wired controller directly is installed on the flat wall.

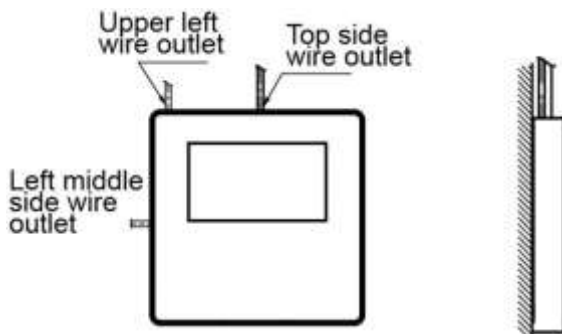

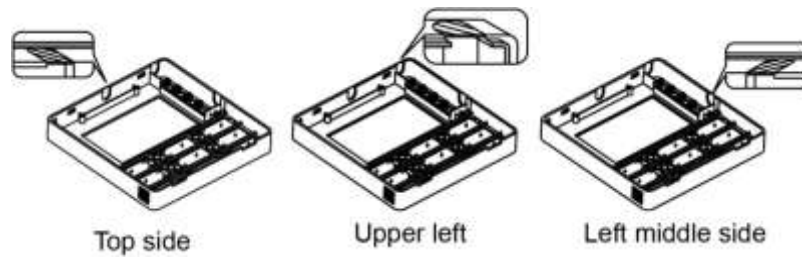

When the wired controller is stalled with electrician box, the back cover of wired controller is already reserved one hole for wire outlet. It is also available for the shielded wire passing by the wall.

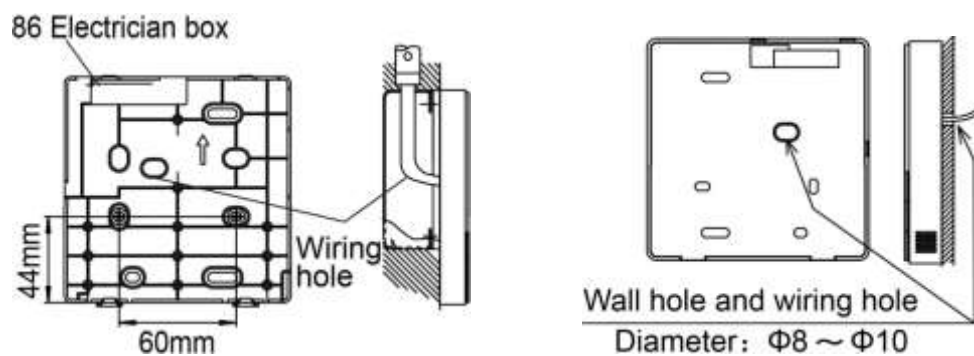

Avoid the water enter into the wired controller, use trap and putty to seal the connectors of wires during wiring installation. When under installation, reserve certain length of the connecting wire for convenient to take down the wired controller while during maintenance.

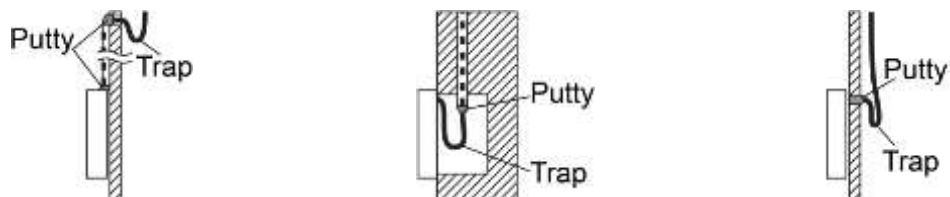

- ✓ Wired controller's front cover installation:

After adjusting the front cover and then buckle the front cover. Avoid clamping the communication switching wire during installation.

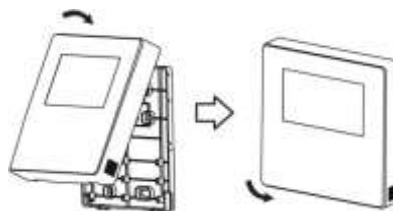

Correct install the back cover and firmly buckle the front cover and back over, otherwise will make the front cover drop off.

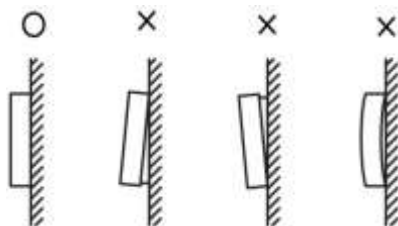

✓ Wired controller initial parameter setting

Change the related functions of the controller through adjusting the initial parameters.

The wired controller initial parameter includes two codes 'XY". The first code 'X' means the function class, the second code 'Y' means detailed configuration of this function.

Step1: Simultaneously press the mode button and fan speed button of the wired controller for 5 seconds to enter the parameter setting state.

Step2: The value of the first code 'X' is '0', press the temperature setting buttons and to adjust the second code value.

Step3: After setting the second code value, press Quiet/OK button to switch the first code to the next value.

Step4: When the first code value is '6', press Quiet/OK button again to exit the parameters setting.

The parameter setting table

First code	Function	Second code				
		0	1	2	3	4
0	Cooling-only/Heat pump selection	Heat pump (Default)	Cooling only	\	\	\
1	Indoor unit communication address setting	Yes (Default)	None	\	\	\
2	Power-off memory	Yes (Default)	None	\	\	\
3	Filter cleaning reminding	Cancel the reminding function	1250 hours	2500 hours	5000 hours	10000 hours
5	Remote receiving function	Yes (Default)	None	\	\	\

6	Centigrade/Fahrenheit display	Centigrade (Default)	Fahrenheit	\	\	\
---	-------------------------------	----------------------	------------	---	---	---

Notes: The second code of the filter cleaning reminding is 2500hours, which as default.

3. Centralized Controller: CRF-10-CM (Optional)



3.1 Centralized controller specifications

Model	CRF-10-CM
Power Supply Voltage	220~240V 50Hz 1Ph
Ambient Temperature Range	-15°C~43°C
Ambient Humidity Range	RH40%~RH90%

Performance Features

1. System composition, centralized control.
2. Keywords and general function description.

3. Technical indices and requirements.
4. Indoor unit working status display.
5. Locking remote controller, locking keyboard of centralized controller and locking running mode.

3.2 Keypad of centralized controller



- 1) **LOCK:** In the mode setting mode, press the lock key, and the remote controller of the currently selected air conditioner will be locked or unlocked. The operation mode is: If the single-machine setting is selected, the operation is performed for the air conditioner of the current address only. If the remote controller of the air conditioner is locked currently, issue the lock command; otherwise, send the lock command. If the single-machine mode is not selected, and the remote controller of one or more currently selected air conditioners is locked, issue the unlock command; if the remote controllers of all currently selected air conditioners are in the non-locked status, issue the remote controller lock command.

When the remote controller of the air conditioner is locked, the air conditioner does not receive remote control signals from the remote controller or wired controller until the remote controller is unlocked. Press THE **QUERY** key and then press the **LOCK** key, and the keys of the centralized controller will be locked or unlocked. If the keys are currently locked, press the **LOCK** and ▲ keys concurrently again, and the keys will be unlocked; if the keys are currently unlocked, press the **LOCK** and ▲ keys concurrently, and the keys will be locked. If the keys are locked, pressing any key will be ineffective, except unlock operation. In the unified setting page, press the ▲ key and the **LOCK** key concurrently to lock all air conditioner modules in the network. The mode locking is cancelled when the key is pressed again.

Note: When locking or cancelling lock, the corresponding icon indication appears or disappears only after all the attached air conditioners are set completely, so it takes a time period. When there are many attached air conditioners, please wait patiently.

- 2) **OK:** In the setting page, press it to send the currently selected mode status and the auxiliary function status to the selected air conditioner, and display the mode setting operation results. After select the operation mode and auxiliary function status information of the air conditioner, if do not press the **OK** key, the selected information will not be sent to the air conditioner, and will not affect the current operation of the air conditioner.

The operations of remote controller locking and unlocking need no pressing of the **OK** key. The command information is sent directly after the **LOCK** key is pressed.

- 3) **SET:** In other display mode, press this key to enter the setting mode. By default, it is single setting, and the first in-service air conditioner is displayed. In setting operation mode, press the key again, and the operation will be performed for all air conditioners in the network. Press it repeatedly to shift between single setting and global setting.



- 4) **QUERY:** Any time when pressing the key, the selected operation mode is to query the operation status of the air conditioner. By default, the first in-service air conditioner will be queried. Through the **ADD** and **REDUCE** keys, the parameter page can be changed to be queried. Through the ▲, ▼, ◀ and ▶ keys, the query status of other air conditioners can be changed.
- 5) ▲: In the query mode, every time when pressing the key, the operation status data of the air conditioner corresponding to the previous row of the matrix will be displayed. If it is currently in the first row, press the key, and the data of the air conditioner corresponding to the last row will be displayed. If this key was held down, the row will decrease one by one. In the setting mode, every time when press the key, if it is in the single operation mode, the air

conditioner corresponding to the last row will be selected. If it is in the global operation mode, no effect will result after the key is pressed. In the main page, press the key to enter the query mode. By default, it is the first in-service air conditioner.

- 6) ▼: In the query mode, every time when pressing the key, the operation status data of the air conditioner corresponding to the next row of the matrix will be displayed. If it is currently in the last row, press the key, and the data of the air conditioner corresponding to the first row will be displayed. If this key was held down, the row will increase one by one. In the setting mode, every time when press the key, if it is in the single operation mode, the air conditioner corresponding to the last row will be selected. If it is in the global operation mode, no effect will result after the key is pressed. In the main page, press the key to enter the query mode. By default, it is the first in-service air conditioner.
- 7) ◀: In the query mode, every time when pressing the key, the operation status data of the previous air conditioner will be displayed. If it is currently on the first machine, press it again, and the data of the last machine will be displayed. If this key was held down, the address will decrease one by one. In the setting mode, every time when pressing the key, if it is in single operation mode, the air conditioner of previous in-service address number will be selected. If it is in the global operation mode, no effect will result after the key is pressed. In the main page, press it to enter the query mode. By default, it is the first in-service air conditioner.
- 8) ▶: In the query mode, every time when pressing the key, the operation status data of the last air conditioner will be displayed. If it is currently on the last machine, press it again, and the data of the first machine will be displayed. If this key was held down, the address will increase one by one. In the setting mode, every time when pressing the key, if it is in single operation mode, the air conditioner of previous in-service address number will be selected. If it is in the global operation mode, no effect will result after the key is pressed. In the main page, press it to enter the query mode. By default, it is the first in-service air conditioner.

- 9) ADD:** In the main page or the query mode, every time when pressing the key, the data of the current page will be displayed. If it is now in the last page, press the key again, and the first page will be displayed. In the setting mode, every time when pressing the key, if it is in the temperature regulation mode, the set temperature will decrease by 1°C (or 2°C) until the highest allowed set temperature. If it is in the timing startup/shutdown time setting mode, select the upper-level set time, if no time is set, 0.0 will be displayed, if hold down the key, the upper-level data will be selected consecutively. The specific change mode is as follows:

0.0→0.5→1.0→1.5→2.0→2.5→3.0→3.5→4.0→4.5→5.0→5.5→6.0→6.5→7.0
 →7.5→8.0→8.5→9.0→9.5→10→11→12→13→14→15→16→17→18→19
 →20→21→22→23→24

- 10) REDUCE:** In the main page or the query mode, every time when pressing the key, the data of the current page will be displayed. If it is now in the first page, press the key again, and the last page will be displayed. In the setting mode, every time when pressing the key, if it is in the temperature regulation mode, the set temperature will decrease by 1°C (or 2°C) until the lowest allowed set temperature. If it is in the timing startup/shutdown time setting mode, select the upper-level set time, if no time is set, 0.0 will be displayed, if hold down the key, the upper-level data will be selected consecutively. The specific change mode is as follows:

0.0←0.5←1.0←1.5←2.0←2.5←3.0←3.5←4.0←4.5←5.0←5.5←6.0←6.5←
 ←7.0←7.5←8.0←8.5←9.0←9.5←10←11←12←13←14←15←16←17←
 ←18←19←20←21←22←23←24

- 11) MODE:** In setting operation mode, press this key to set the operation.

→Cooling→Heating→Fan→Stop

In other display mode, press this key to enter the setting mode. By default, it is single-machine setting, and the first in-service air conditioner is displayed.

- 12) FAN:** In setting operation mode, press this key to set the fan of the indoor unit of the air conditioner to run in the following picture:

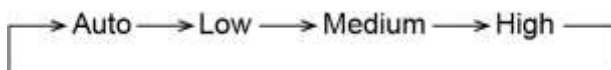

13) TIME ON/TIME OFF: In setting operation mode, press them to set the timing startup of air conditioner. Press them again to exit the timing setting, and restore the normal temperature regulation operation mode.

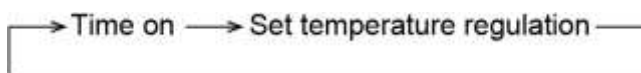

14) SWING: In the setting operation mode, press this key to enable or disable the swing function. If all currently selected air conditioner have no swing function, no effect will result after pressing the key.

15) RESET: Anytime when the **RESET** key is pressed, the centralized controller will reset. The result is the same as the result of restoring power-on after power failure.

16) ON/OFF: Any time when pressing the key, the centralized startup/shutdown operation is performed for all current in-service air conditioners in the centralized controller network. If all in-service air conditioners in the network are in the power-off status, press the key to perform the startup operation. If it is in the mode setting page currently, and the parameters such as startup mode, temperature and air speed are selected, the air conditioner will be started according to the selected parameters. If no mode is selected currently, and the air conditioner is powered off or it is in other display page currently, and the default startup mode is: cooling, high speed fan air, set temperature 24°C, swing function enabled. The default startup mode is locked according to the system mode or judged according to other constraint conditions. If any conflict exists, the next conflict-free mode will apply automatically. If conflict exists for all modes, startup will be impossible. If one or more in-service air conditioners in the network (including in the timing process of timing startup/shutdown), pressing this key will shut down all air conditioners. When performing the shutdown operation, the shutdown command is issued to the air conditioners in the startup status only, and is not issued to those in the shutdown status.

3.3 Display of the centralized controller

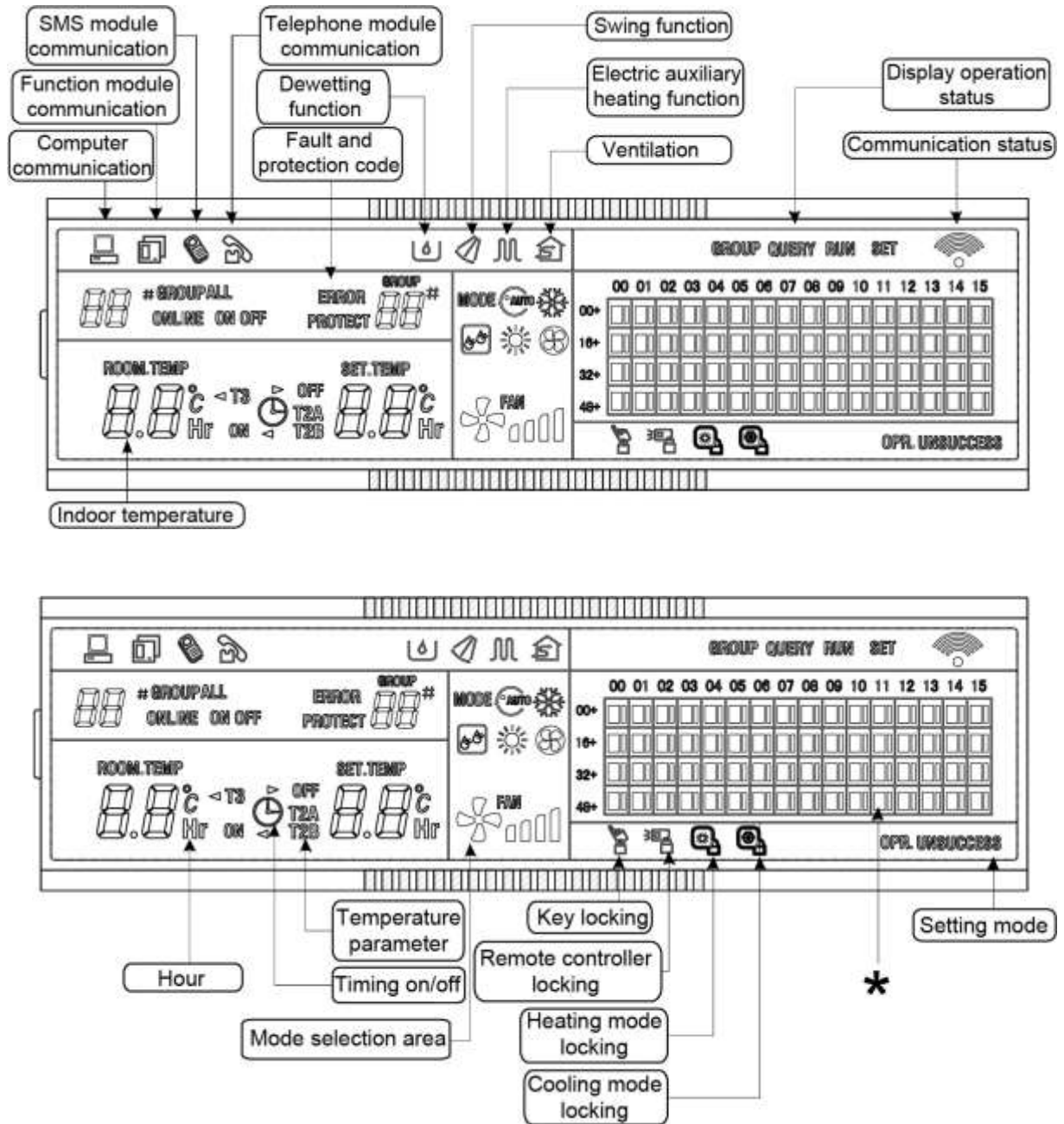

*: The matrix is composed of 4x16 grids and each grid is composed of two blocks of different sizes. The matrix include horizontal coordinates 00-15 and vertical coordinates 00+, 16+, 32+ and 48+, which indicate the address of the indoor unit. The sum of the horizontal coordinate and vertical coordinate of the grid is the address of the grid. Each grid corresponds to an indoor unit of this address.

3.4 Operation instructions

1) System composition:

- ✓ The centralized controller is used to perform centralized control and data query for the network air conditioner. Each centralized controller can communicate with a maximum of 64 air conditioners to make up an air conditioner LAN, and implement centralized monitoring for the air conditioners in the network.
- ✓ The centralized controller can be interfaced with computer or gateway to implement centralized control and status query for all air conditioners in the network. It can be connected with WAN via computer or gateway to implement remote computerized control (with support of computer software). Each local computer or gateway can be connected to 16 centralized controllers as a maximum.
- ✓ The master or slave answer mode is implemented for communication between the centralized controller and the air conditioner, between the computer and the centralized controller. In the LAN composed of centralized controller and air conditioner, the centralized controller is a master, and the air conditioner is a slave. In the LAN composed of computer and centralized controller, the computer or gateway is a master, and the centralized controller is a slave.
- ✓ The schematic diagram of network control system composition of air conditioner:

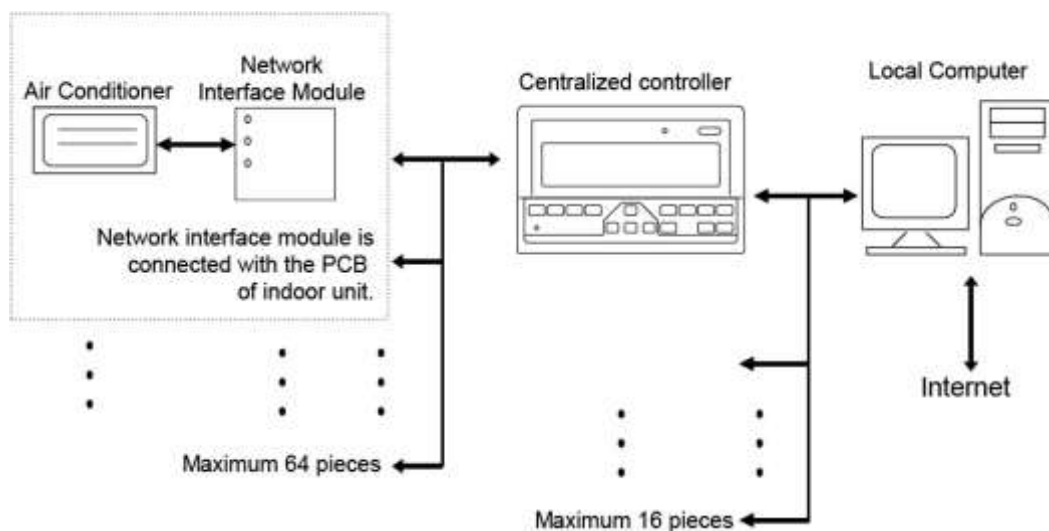

2) Keywords and general function description:

- ✓ Power on or reset:

When the centralized controller is powered on or reset, all display segments of the LCD are luminous for 2 seconds and then goes off. 1 second later, the system enters the normal display status. The centralized controller is in the main page display status and displays the first page, and searches the in-service air conditioners in the network. Once the search is finished, the centralized controller enters the mode setting page, and sets the first in-service air conditioner by default.

✓ Network area address of centralized controller:

The local computer or gateway can be connected with 16 centralized controllers for communication. Each centralized controller serves as an area of the air conditioner network. The centralized controllers are differentiated by bit selection address. The configurable range is 0~15.

✓ State indication:

If any local keypad operation is setting the operation status of the air conditioner, the indicator is on when the signals are sent. Upon completion of the setting process, the indicator goes off. If an in-service air conditioner in the network is faulty, or the centralized controller network itself is faulty, the indicator will blink at 2Hz.

If one or more in-service air conditioners in the network are running, including under setting of timing start or shutdown, the indicator will be luminous. Otherwise, the indicator is off.

✓ Locking of centralized controller:

After receiving the centralized controller locking command sent from the computer, the centralized controller disables the startup or shutdown and setting of the air conditioner, and sends commands to lock remote controllers of all air conditioners in the network of the centralized controller. After receiving the unlocking command, the centralized controller enables the startup or shutdown operation, and sends commands to unlock the remote controller of all air conditioners.

The locking status of the remote controller can be locked or unlocked by the computer or centralized controller separately. The locking status of the centralized controller is memorized after power failure of the centralized controller, and will not vanish after the power supply is restored, unless the command of unlocking is received.

✓ Mode locking function:

After the mode locking command is received, the command is forwarded to the air conditioner, and the centralized controller displays the mode locking flag. After the command of unlocking is received, the non-conflict mode can be selected freely. The centralized controller can also lock modes of all indoor units.

✓ Emergent shutdown and compulsory startup:

If the emergent switch of the centralized controller was switch off, all air conditioners in the network of the centralized controller will be shut down compulsorily. The centralized controller and computer and all functional modules are disabled from startup and shutdown until the foregoing switch is turned off. If the switch was turned on, all air conditioners in the network of the centralized controller will be start up compulsorily. By default, they will run in the cooling mode. The startup and shut-down operations of the centralized controller and the computer and all functional modules will be disabled (Only the command of startup is sent to the air conditioner, without affecting operation of the remote controller after startup) until the foregoing switch is turned off. If the foregoing two switches are turned on concurrently, the emergent shutdown switch shall have preference.

3.5 General display data entries

1) General display data is displayed in all display pages.

- ✓ Under the interconnected control of the computer or gateway, the data is displayed in graphic (🖥️). Otherwise, no data is displayed.
- ✓ If the centralized controller is connected with the functional module for communication, the data is displayed in graphics (📺). Otherwise, no data is displayed.
- ✓ If the centralized controller is connected with the SMS remote control module for communication, the data is displayed in graphics (📱). Otherwise, no data is displayed.
- ✓ If the centralized controller is connected with the telephone remote control module for communication, the data is displayed in graphics (☎️). Otherwise, no data is displayed.
- ✓ In normal operation of the centralized controller, the periodical cycle module communicates with the network interface module, and the data is displayed dynamically and cyclically: (blank), 📶, 📶, 📶.
- ✓ In the centralized control locked status or the keypad locked status, the locking flag (🔒) is displayed. After unlocking, it is not displayed. In the centralized controller locked

status or the keypad locked status, the locking flag is displayed constantly. If both of them are locked concurrently, the locking flag is displayed constantly.

- ✓ In the setting page, if the selected air conditioner is in the remote controller locked status (in case of non-single machine operation, as long as one machine is in the remote controller locked status, it is deemed the locked status), the flag (🔒) is displayed constantly.
- ✓ If all indoor units lock the cooling mode, this flag (❄️) will display, and if all indoor units lock the heating mode, the flag (🔥) will display.

2) Data display handling

- ✓ Indoor unit code (address) display: display range: 00~63, and with # being luminous concurrently.
- ✓ Indoor temperature display: display range: 00~99°C. The indoor temperature is displayed concurrently. If the temperature is higher than 99°C, 99°C will be displayed. If the temperature value is invalid, '--' will be displayed.
- ✓ If timing startup or shutdown is set, the flag (🕒) is displayed.
- ✓ T3, T2A and T2B display: in the single-machine query page, display can shift between T3, T2A and T2B; by the way, the temperature value is displayed concurrently, with the corresponding °C being luminous.
- ✓ In case of air conditioner fault or protection, the corresponding fault code or protection, the corresponding fault code or protection code can be displayed.
- ✓ Liquid crystal matrix display description:

	00	01	02	03	04	05	06	07	08	09	10	11	12	13	14	15
00+	■	■	■	■	■	■	■	■	■	■	■	■	■	■	■	■
16+	■	■	■	■	■	■	■	■	■	■	■	■	■	■	■	■
32+	■	■	■	■	■	■	■	■	■	■	■	■	■	■	■	■
48+	■	■	■	■	■	■	■	■	■	■	■	■	■	■	■	■

The liquid crystal matrix is composed of 4×16 grids, and each grid is composed of two blocks of different sizes. The matrix includes horizontal coordinates 00~15 on the upper side and vertical coordinates 00+, 16+, 32+ and 48+ on the left side, which indicate the address of the indoor unit. The sum of the horizontal coordinate and the vertical

coordinate of the grid is the address of the grid. Each grid corresponds to an indoor unit of this address. One grid is composed of two blocks of different sizes. The status indication table is as follows;

	Constantly on	Slow blink		Fast blink
Big black block	In-service	Selected		Out of service
Small black block	Power on		Fault of indoor or outdoor unit	Power off

3) LCD display description

✓ Description of the standby page

The LCD displays the standby page, 60 air conditioners are in service, of which 28 are powered on and 32 off.

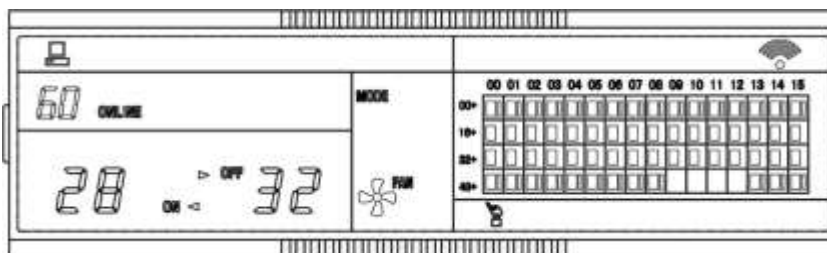

In the matrix, the big dots from (00, 16+) to (15, 32+) are luminous, and the small dots are not luminous. It indicates the 32 air conditioners with the addresses from 16 to 47 are powered off.

In the matrix, the big and small dots from (09, 48+) to (12, 48+) are not luminous. It indicates the four air conditioners with the address from 57 to 60 are outside the network.

All other big and small dots in the matrix are luminous. It indicates all other air conditioners are in the network and powered on.

The address of the air conditioner is sum of the coordinates. For example, the address of (09, 48+) is $09+48=57$.

The centralized controller keypad is locked, and the centralized controller communicates with the computer normally.

✓ Description of the query page

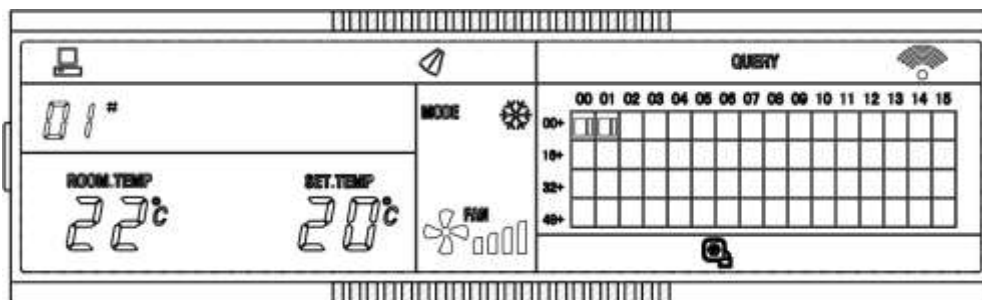

The LCD displays the query page, and the air conditioner with the address of 08 is being queried. Mode of the air conditioner with the address 01 is cooling, high speed air supply, swing on, indoor temperature 22°C, setting temperature 20°C and cooling mode locked.

In the matrix, only the big and small black dots at (00, 00+) and (01, 00+) are luminous. It indicates the in-service and power-on status of the air conditioners with the addresses of 00 and 01.

The centralized controller communicates with the computer normally.

✓ Description of the setting page

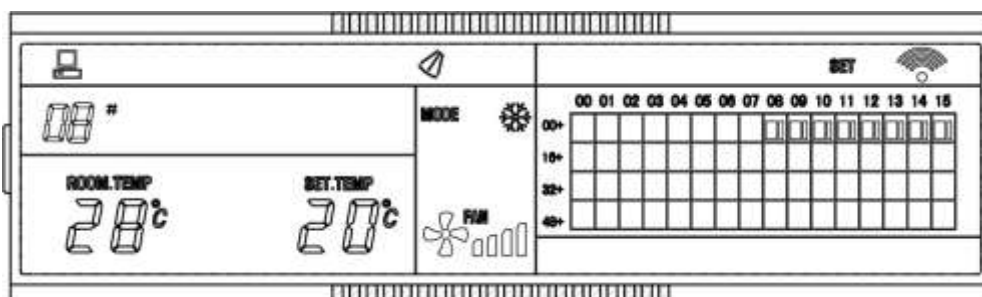

The LCD displays the setting page, and queries the air conditioner with the address of 08. The mode of the air conditioner with the address 08 is: cooling, high speed air supply, swing on, indoor temperature 28°C, setting temperature 22°C and cooling.

In the matrix, only the big black dots from (08, 00+) to (15, 00+) are luminous. It indicates the air conditioners with the addresses from 08 to 15 are in service.

The centralized controller communicates with the computer normally.

✓ Fault page display description

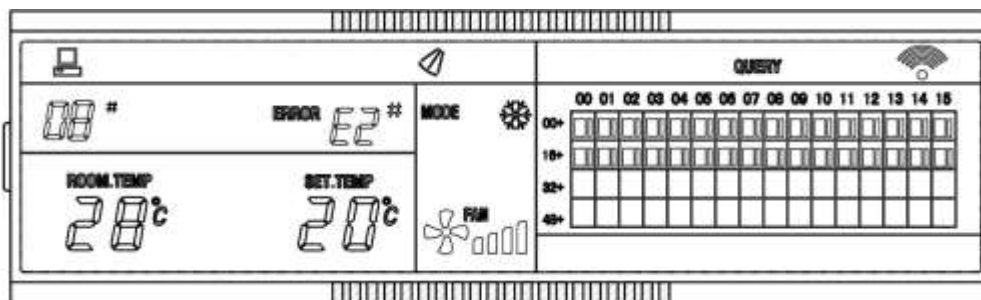

Query the air conditioner with the address of 08 in the query page. The air conditioner with the address of 08 is faulty, and the fault code is E2. The big black dot below (08, 00+) blinks.

In the matrix, only the big and small black dots from (00, 00+) to (15, 16+) illuminate. It indicates the in-service status of the air conditioners with the addresses from 00 to 31.

The centralized controller communicates with the computer normally.

Fault code table:

Fault code	Fault content
EF	Other faults
ED	Outdoor unit fault protection
EA	Over-current of compressor (4 times)
E9	Fault of communication between main board and display board
E7	EEPROM error
E6	Zero crossing detection error
E5	T3 or T4 temperature sensor fault
E4	T2B sensor fault
E3	T2A sensor fault
E2	T1 sensor fault
E1	Communication fault
E0	Phase order error or phase loss

Protection code table:

Fault code	Fault content
------------	---------------

PF	Other protection
P8	Over-current of compressor
P6	Discharge low pressure protection
P5	Discharge high pressure protection
P4	Discharge pipe temperature protection
P2	Condenser hi-temperature protection
P1	Anti-cool air or defrost protection (Only for heat pump units)
P0	Evaporator temperature protection

3.6 Installation

The wireless remote controller is the standard controller for split series air conditioner. Wired controller as optional controller can directly be connected with the display board of the indoor units. Centralized controller should be connected with the main PCB board of the indoor unit through network interface module, which is named as CARR-NIM01.



1) The installation of network interface module

Outlook of CARR-NIM01

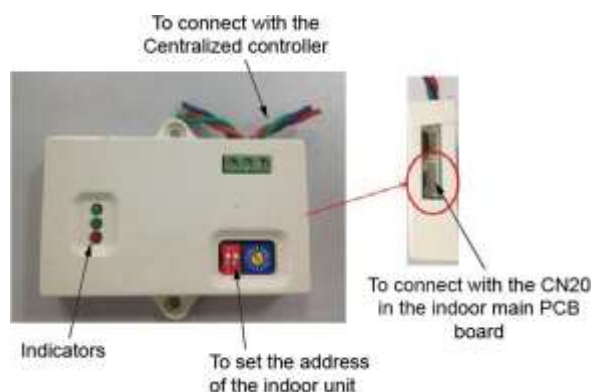

The first green lighter: Ready indicator. When the module and controller is connected rightly, the lighter will be on; otherwise, it will be off. If the unit is in the status of locking remote controller and locking mode, the lighter will flash.

The second green lighter: Communication indicator. When there is any signal between the network interface module and centralized controller, the indicator will be on.

The third lighter: Alarm indicator. If there is any error between the module and controller for communication, it will be on.

Dimension of CARR-N1M01

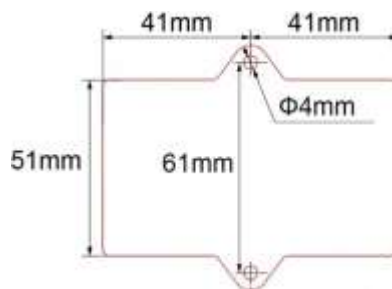

Connect the network interface module with the port CN20 in the main PCB board of indoor unit through the signal wire, which is as the attachment of the module.

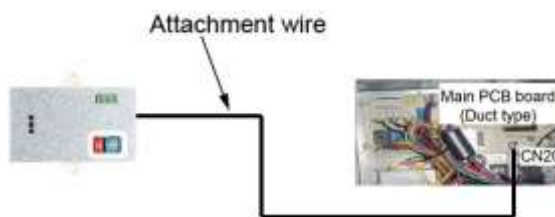

Fix the network interface module on the wall near the indoor unit. And set the different address of the indoor unit.

2) The installation of centralized controller

Open the front panel of the centralized controller by screwdriver as the following picture: (Unit: mm)

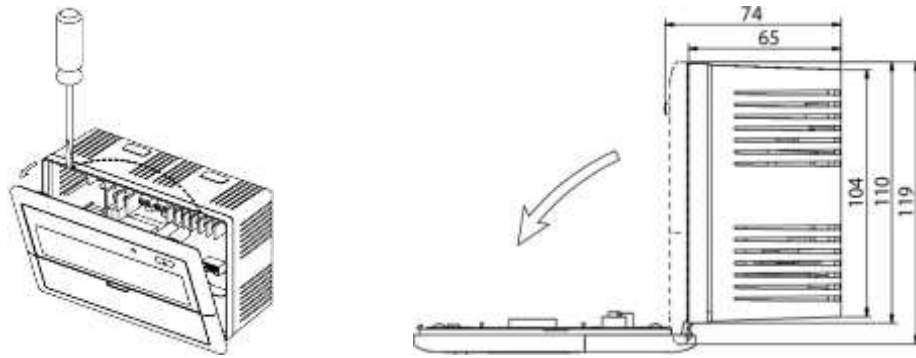

According to size of the hole in controller body, fix the controller on the place as needed. (Unit: mm)

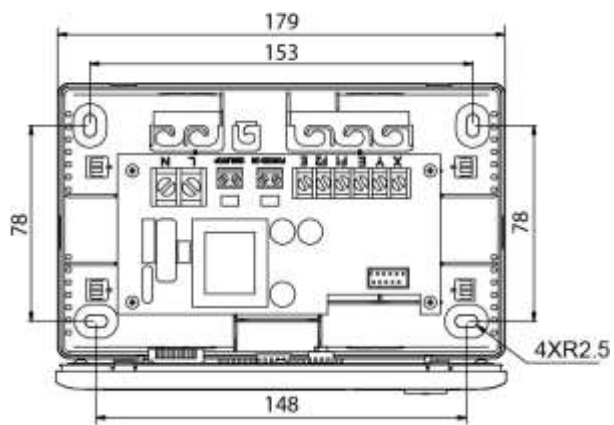

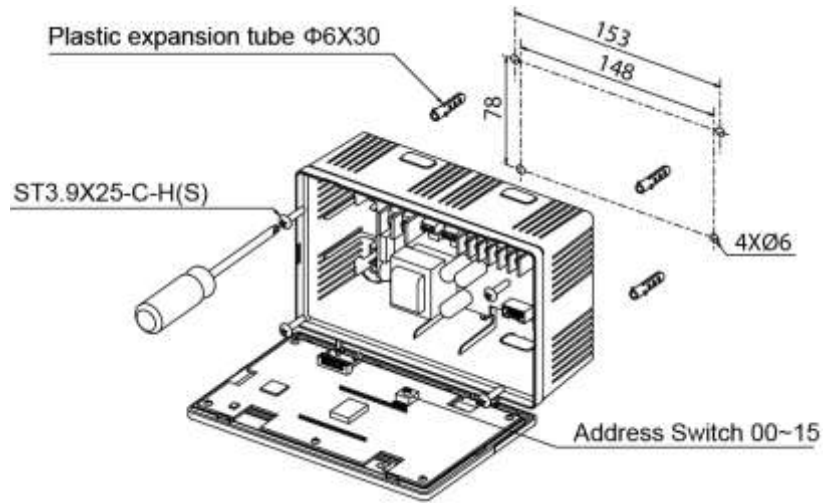

3) The wire connection

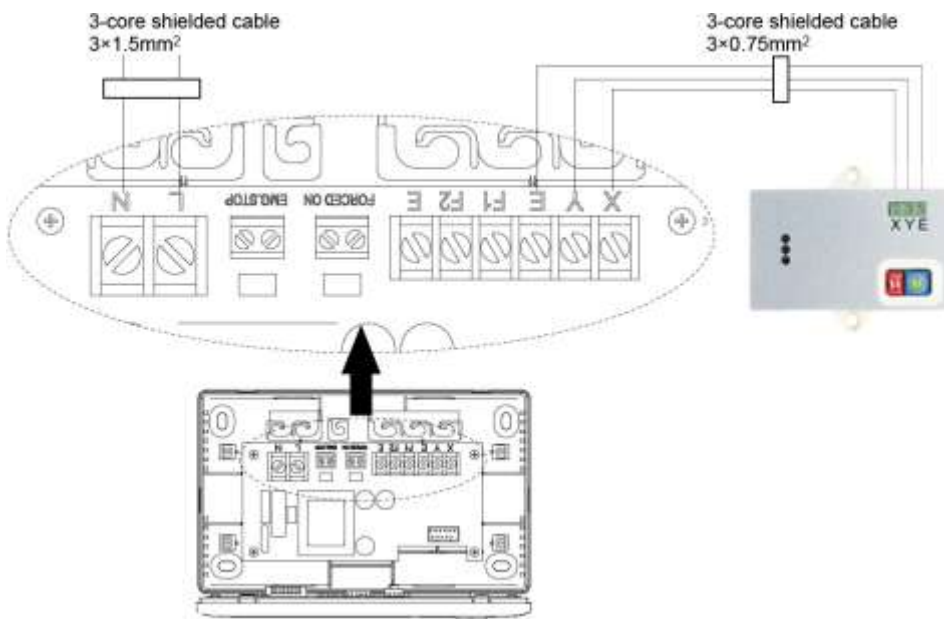
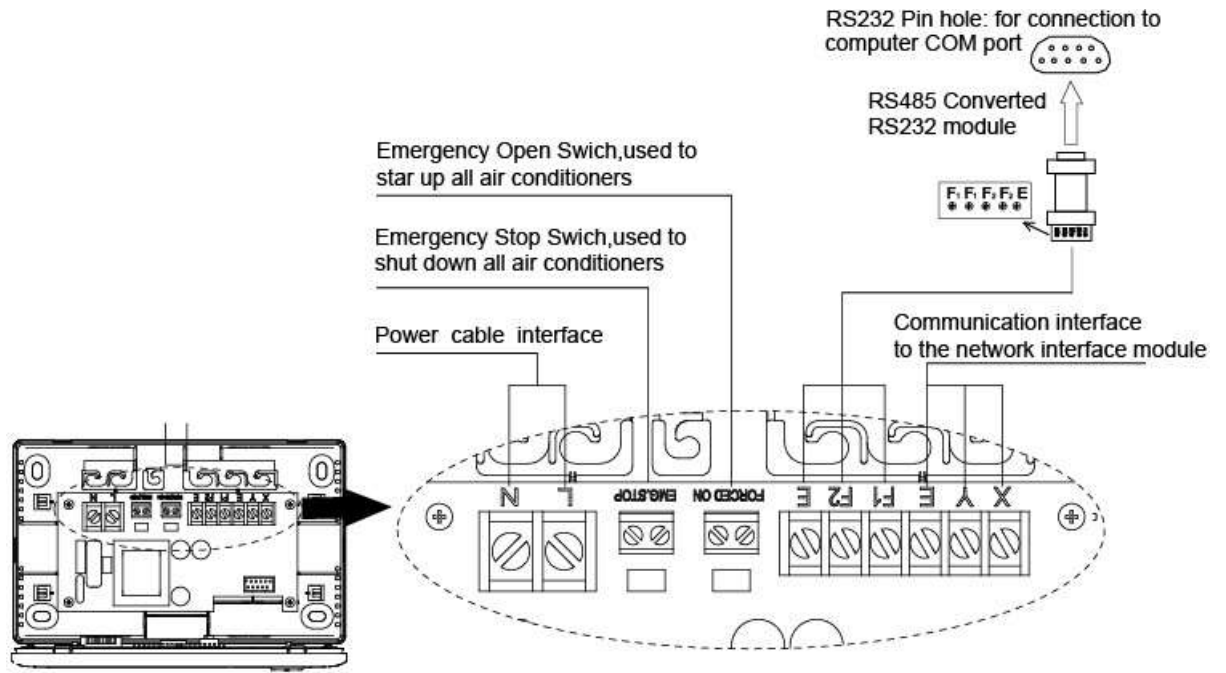

Correct connection

Incorrect connection

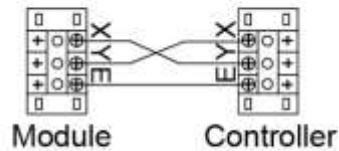
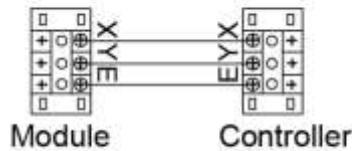

Incorrect connection

Incorrect connection

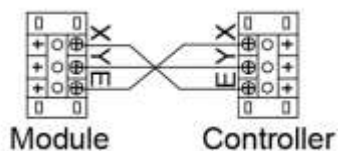
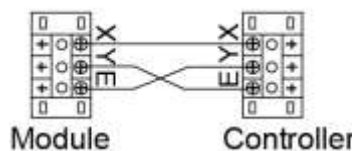

4) System wiring instruction

- ✓ Wiring diagram of building network air conditioning system

Wiring diagram with good communication effect

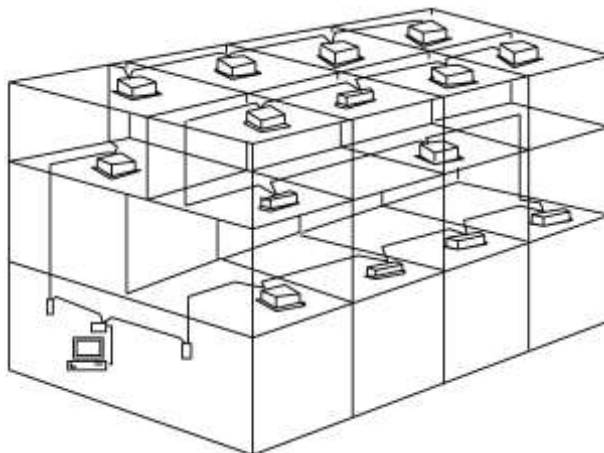

Wiring diagram with poor communication effect (not recommended because it may lead to poor communication)

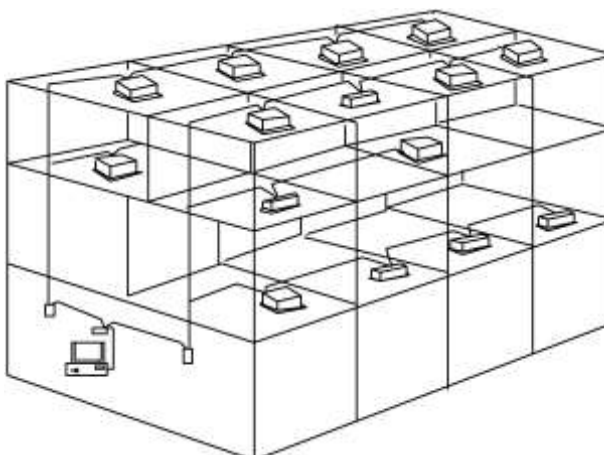

- ✓ System wiring diagram of centralized monitoring and indoor unit of air conditioner

Both of the following wiring modes of centralized monitor and indoor unit are applicable:

(Quantity of indoor units connected with each centralized monitor is less than or equal to 64).

