

HGX66e/1540-4 S

Engine: 380-420V Y/YY -3- 50Hz PW

Refrigerant: R404A, R507

Subject:

Performance data

Application: Refrigeration & AC

Refrigerant	R404A, R507	Compressor refrigeration capacity	70.20 kW
Reference temperature	Dew point	Evaporator refrigeration capacity	70.20 kW
Power supply	50 Hz, 400 V	Power consumption	29.90 kW
Supply frequency	50 Hz	Current draw (400 V)	53.70 A
Evaporating temperature	-10.0 °C	Coefficient of performance (COP/EER)	2.35
<i>Evaporating pressure (abs.)</i>	<i>4.34 bar</i>	Condensing capacity	101.00 kW
Condensing temperature	45.0 °C	Mass flow	0.584 kg/s
<i>Condensing pressure (abs.)</i>	<i>20.47 bar</i>	Discharge end temperature	90.2 °C ¹⁾
Suction gas temperature	20 °C		
Subcooling (outside cond.)	0 K		
Usable superheat	100%		

1) The stated value of the discharge end temperature is a mere calculated value. Additional cooling and heat dissipation are not considered. Deviations (particularly in deep freezing applications) from the real measured discharge temperature during operation are possible.

Subject to change without notice

To: venolia.stoffels@metraclark.co.za

From:

02.08.2022
Page 1 of 11

VAP 11.12.0

HGX66e/1540-4 S



Engine: 380-420V Y/YY -3- 50Hz PW

Refrigerant: R404A, R507

Subject:

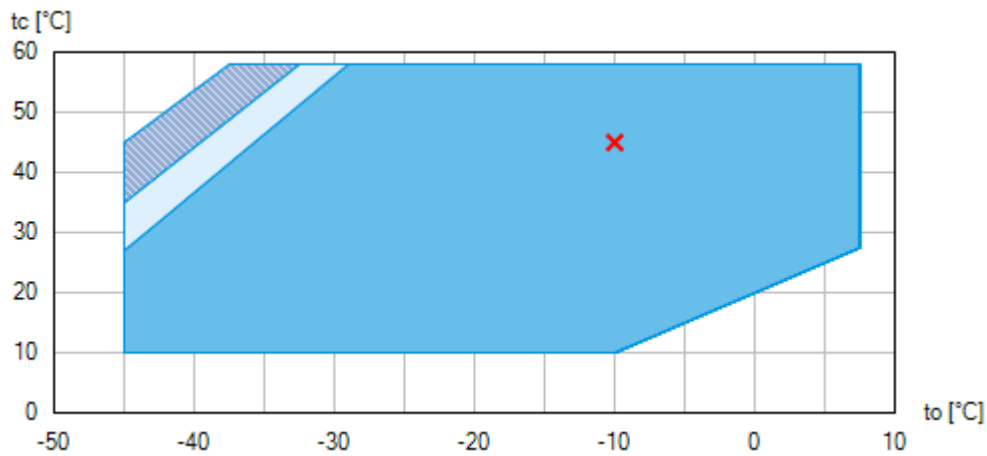
Operating limits



-  Unlimited application range
-  Supplementary cooling or reduced suction gas temperature ($\Delta t_{oh} < 20K$)
-  Supplementary cooling and reduced suction gas temperature ($\Delta t_{oh} < 20K$)

Compressor operation is possible within the limits shown on the diagrams of application. Please note the coloured areas. Compressor application limits should not be chosen for design purposes or continuous operation. Axis values refer to dew point (saturated vapour line).

Subject to change without notice

To: venolia.stoffels@metraclark.co.za

From:

02.08.2022
Page 2 of 11

VAP 11.12.0

HGX66e/1540-4 S

Engine: 380-420V Y/YY -3- 50Hz PW

Refrigerant: R404A, R507

Subject:

Technical data

Number of cylinders / Bore / Stroke	6 / 75 mm / 58 mm
Displacement 50/60 Hz (1450/1740 1/min)	133,8 / 160,5 m ³ /h
Voltage ¹⁾	380-420V Y/YY -3- 50Hz PW
	440-480V Y/YY -3- 60Hz PW
Winding divided into	50% / 50%
Max. working current ²⁾	75.0 A
Max. power consumption ²⁾	44.4 kW
Starting current (rotor blocked) ²⁾	196.0 / 335.0 A
Motor protection	INT69 G
Protection terminal box	IP 66
Weight	285 kg
Frequency range ³⁾	25 - 60 Hz
Max. permissible overpressure (g) (LP/HP) ⁴⁾	19 / 28 bar
Connection suction line SV	54 mm - 2 1/8 "
Connection discharge line DV	42 mm - 1 5/8 "
Lubrication	Oil pump
Oil type R134a, R404A, R407A/C/F, R448A, R449A, R450A, R513A	BOCKlub E55
Oil type R22	BOCKlub A46
Oil charge	4,4 Ltr.
Oil sump heater	230 V - 1 - 50/60 Hz, 160 W
Dimensions Length / Width / Height	810 / 557 / 467 mm
Sound power level L _{WA} ⁵⁾	88 db(A) @ -35/+40 °C
	83 db(A) @ -10/+45 °C
	82 db(A) @ +5/+50 °C
Sound pressure level L _{pA} ⁵⁾	75 db(A) @ -35/+40 °C
	70 db(A) @ -10/+45 °C
	68 db(A) @ +5/+50 °C

Subject to change without notice

To: venolia.stoffels@metraclark.co.za

From:

02.08.2022
Page 3 of 11

VAP 11.12.0

HGX66e/1540-4 S

Engine: 380-420V Y/YY -3- 50Hz PW

Refrigerant: R404A, R507

Subject:

-
- 1) Tolerance ($\pm 10\%$) relates to the mean value of the voltage range. Other voltages and current types on request

All data are based on voltage rms values

PW = part winding, motors for part winding starting
(no start unloaders required)
Designs for Y/D on request
 - 2) - The stated value for the max. power consumption is valid for the adjusted power supply.

- Starting current (rotor blocked):
 - Part winding (PW) motors: Winding 1 / Winding 1+2
 - Delta/Star (Δ/Y) motors: Δ / Y- Take account of the max. operating current / max. power consumption for designing motor contractors, feed lines, fuses and motor protection switches. Motor contractors: Consumption category AC3.
 - 3) The maximum permissible working current of the compressor (I_{max}) must not be exceeded. Take account of the guidelines for use of frequency inverter (see compressor assembly instruction or selection software).
 - 4) LP = Low pressure
HP = High pressure
 - 5) Declared dual-number noise emission values are in accordance with ISO 4871. The corresponding uncertainty to the sound power level is $K_{WA} = 2,5$ dB and to the sound pressure level is $K_{pA} = 2,5$ dB. The values are valid for 50 Hz with the refrigerant R404A at the standard rating points according to EN 12900.
 - A-weighted sound power level L_{WA} (re 1 pW), in decibel. To determine the values, measurement methods of the ISO 3740 standard with accuracy class 2 or higher were used .
 - A-weighted sound pressure level L_{pA} (re 20 μ Pa), in decibel. The values are calculated from the sound power level in accordance with ISO 11203: $L_{pA} = L_{WA} - Q_2$ at a distance of $d = 1$ m to the reference box.

Subject to change without notice

To: venolia.stoffels@metraclark.co.za

From:

02.08.2022
Page 4 of 11

VAP 11.12.0

HGX66e/1540-4 S

Engine: 380-420V Y/YY -3- 50Hz PW

Refrigerant: R404A, R507

Subject:

Performance data table

Application: Refrigeration & AC

Reference temperature: Dew point

Supply frequency: 50 Hz

Voltage: 400 V

Suction gas temperature: 20 °C

Subcooling (outside cond.): 0 K

tc [°C]		to [°C]									
		0.0	-5.0	-10.0	-15.0	-20.0	-25.0	-30.0	-35.0	-40.0	-45.0
10.0	Q [W]			117000	95900	77700	62100	48900	37900	29000	21900
	P [kW]			17.30	17.10	16.50	15.60	14.40	13.00	11.50	10.00
	I [A]			39.20	39.00	38.40	37.60	36.60	35.50	34.30	33.30
15.0	Q [W]		134000	111000	90800	73400	58500	45800	35300	26600	19500
	P [kW]		19.70	19.50	18.90	17.90	16.70	15.20	13.50	11.80	10.10
	I [A]		41.60	41.40	40.80	39.80	38.60	37.20	35.90	34.50	33.30
20.0	Q [W]	152000	127000	105000	85600	69000	54800	42700	32600	24200	17300
	P [kW]	22.40	22.20	21.60	20.60	19.20	17.60	15.90	14.00	12.00	10.10
	I [A]	44.60	44.30	43.60	42.50	41.10	39.50	37.90	36.20	34.70	33.30
25.0	Q [W]	143000	119000	98200	80200	64500	51000	39600	29900	21800	15200
	P [kW]	25.30	24.60	23.60	22.10	20.40	18.50	16.50	14.30	12.20	10.10
	I [A]	47.90	47.10	45.80	44.20	42.40	40.40	38.40	36.50	34.80	33.30
30.0	Q [W]	133000	111000	91500	74600	59800	47200	36400	27200	19600	13200
	P [kW]	28.00	26.90	25.40	23.60	21.50	19.30	17.00	14.60	12.30	10.00
	I [A]	51.20	49.80	48.00	45.80	43.50	41.20	38.90	36.80	34.90	33.30
35.0	Q [W]	124000	103000	84600	68800	55100	43200	33200	24600	17400	11300
	P [kW]	30.50	28.90	27.00	24.80	22.50	20.00	17.40	14.80	12.30	9.93
	I [A]	54.50	52.50	50.00	47.40	44.60	41.90	39.30	36.90	34.90	33.20
40.0	Q [W]	114000	94300	77500	62800	50200	39300	30000	22100	15300	9580
	P [kW]	32.80	30.80	28.50	26.00	23.30	20.50	17.70	14.90	12.20	9.71
	I [A]	57.70	55.00	51.90	48.70	45.50	42.40	39.60	37.00	34.80	33.00
45.0	Q [W]	104000	85700	70200	56800	45200	35200	26800	19500	13400	8030
	P [kW]	34.90	32.50	29.90	27.00	24.00	20.90	17.90	14.90	12.00	9.41
	I [A]	60.80	57.40	53.70	50.00	46.30	42.90	39.70	37.00	34.70	32.80
50.0	Q [W]	92900	76800	62700	50600	40100	31200	23600	17100	11500	
	P [kW]	36.90	34.10	31.00	27.80	24.50	21.20	17.90	14.70	11.70	
	I [A]	63.60	59.50	55.30	51.00	47.00	43.20	39.80	36.90	34.50	
55.0	Q [W]	82200	67600	55100	44200	35000	27100	20400	14700		
	P [kW]	38.60	35.40	32.00	28.50	24.90	21.30	17.90	14.50		
	I [A]	66.20	61.50	56.70	51.90	47.40	43.30	39.70	36.70		

 Supplementary cooling or reduced suction gas temperature ($\Delta t_{oh} < 20K$)

 Supplementary cooling and reduced suction gas temperature ($\Delta t_{oh} < 20K$)

to Evaporating temperature

tc Condensing temperature

Q Compressor refrigeration capacity

P Power consumption

I Current draw

Subject to change without notice

To: venolia.stoffels@metraclark.co.za

From:

02.08.2022
Page 5 of 11

VAP 11.12.0

HGX66e/1540-4 S

Engine: 380-420V Y/YY -3- 50Hz PW

Refrigerant: R404A, R507

Subject:

Scope of supply

Semi-hermetic six-cylinder reciprocating compressor with drive motor for part winding start
Single-section compressor housing with hermetically integrated electric motor

Rear bearing flange prepared for oil differential pressure sensor DELTA-P II

Winding protection with PTC resistor sensors and electronic trigger unit INT69 G
115-230 V AC, 50/60 Hz, IP00

Oil pump

Possibility of connection of oil level controllers ESK, AC+R or CARLY

Possibility of connection of oil level controllers Traxoil ¹⁾

Oil charge:

HG: **BOCK**lub A46

HGX: **BOCK**lub E55

Sight glass

Internal safety valve

Suction and discharge line valve

Inert gas charge

Accessories

Capacity regulator 110 V - 1 - 50/60 Hz, IP65
1-2 capacity regulator = 66/33% residual capacity ²⁾

Capacity regulator 230 V - 1 - 50/60 Hz, IP65
1-2 capacity regulator = 66/33% residual capacity ²⁾

Cylinder cover prepared for capacity regulator ³⁾

Oil sump heater 230 V - 1 - 50/60 Hz, 160 W ³⁾

Oil temperature sensor (Pt1000, for external evaluation) ³⁾

USB converter for INT69 G Diagnose ⁴⁾

Oil differential pressure sensor DELTA-P II 220-240 V - 1 - 50/60 Hz ⁴⁾

Connection piece suction and discharge valve in welding design

Oil service valve

Thermal protection thermostat per cylinder cover ³⁾

Oil pressure safety switch MP54 230 V - 1 - 50/60 Hz, IP20 ⁴⁾

INT69 G Diagnose 115-230 V AC, 50/60 Hz, IP00 (INT69 G not applicable) ³⁾

Subject to change without notice

To: venolia.stoffels@metraclark.co.za

From:

02.08.2022
Page 6 of 11

VAP 11.12.0

HGX66e/1540-4 S

Engine: 380-420V Y/YY -3- 50Hz PW

Refrigerant: R404A, R507

Subject:

DP-Modbus Gateway 115-230 V AC, 50/60 Hz, IP00 including adapter cable ⁴⁾

Modbus-LAN Gateway 230 V AC, 50/60 Hz, IP00 ⁴⁾

Additional fan

230 V AC - 1 - 50 Hz, 97 W, IP44

230 V AC - 1 - 60 Hz, 128 W ⁴⁾

Step protection ⁴⁾

Injection nozzle for liquid injection ⁴⁾

4 anti-vibration pads enclosed

Special voltage and/or frequency (on request)

-
- 1) Only with additional adapter possible
 - 2) Capacity regulator premounted, control unit enclosed
 - 3) Mounted
 - 4) Enclosure

Subject to change without notice

To: venolia.stoffels@metraclark.co.za

From:

02.08.2022
Page 7 of 11

VAP 11.12.0

HGX66e/1540-4 S

Engine: 380-420V Y/YY -3- 50Hz PW

Refrigerant: R404A, R507

Subject:

Dimensions and connections

Subject to change without notice

To: venolia.stoffels@metraclark.co.za

From:

02.08.2022
Page 8 of 11

VAP 11.12.0

HGX66e/1540-4 S

Engine: 380-420V Y/YY -3- 50Hz PW

Refrigerant: R404A, R507

Subject:

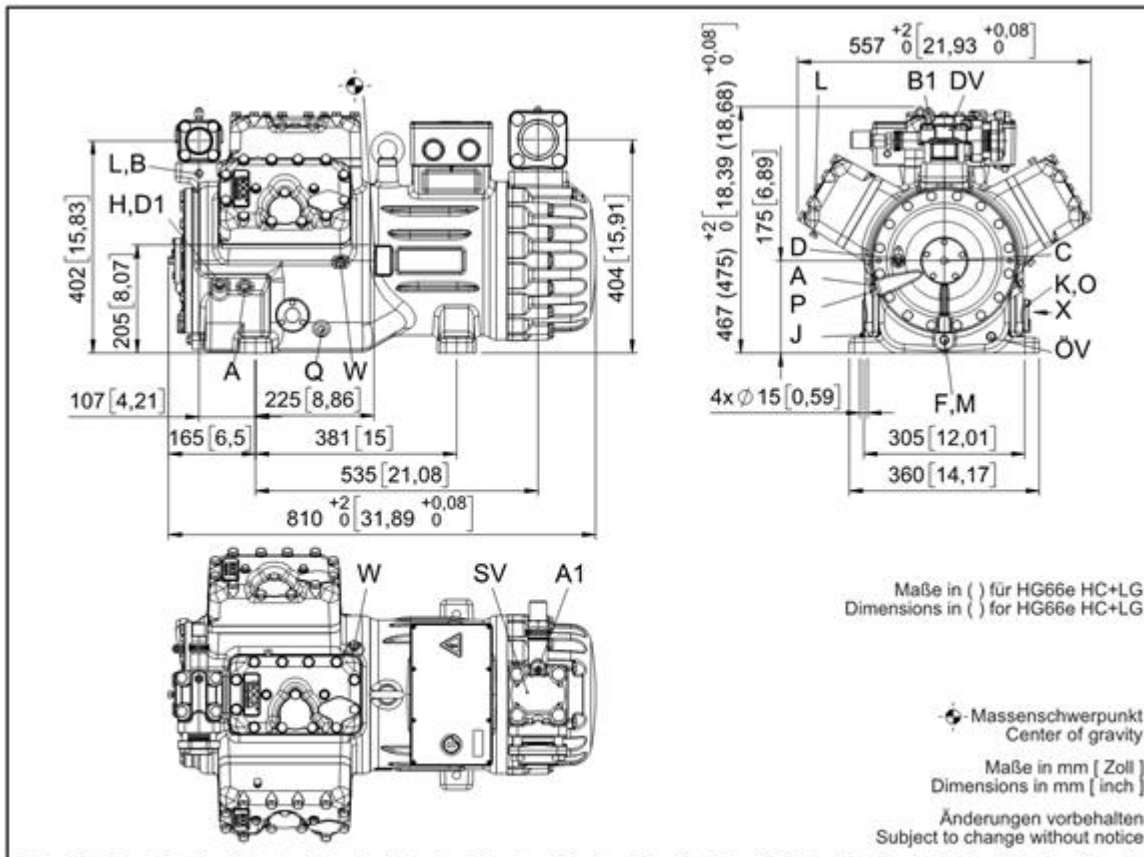

Maße Zubehör / Dimensions Accessories

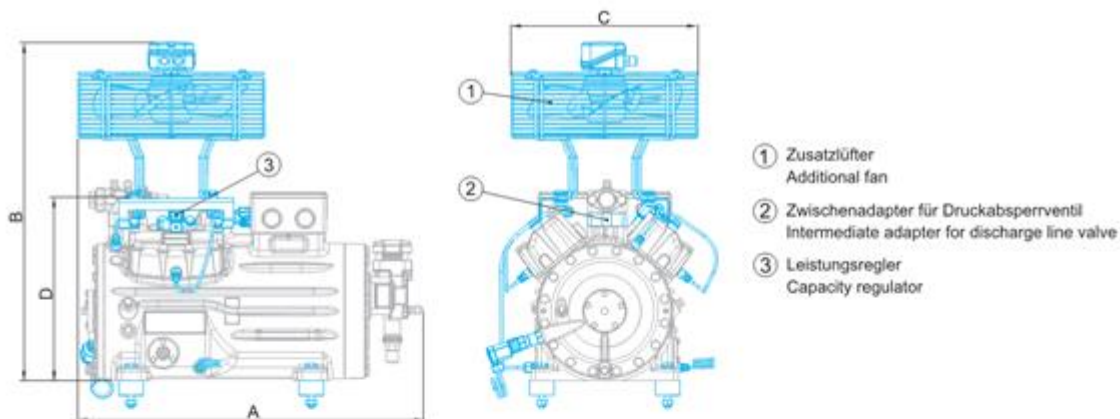

Typ / Type	A mm / inch	B mm / inch	C mm / inch	D mm / inch
HG12P	ca. 460 / 18	ca. 500 / 20	ca. 315 / 12	—
HG22e	ca. 525 / 21	ca. 610 / 24	ca. 380 / 15	—
HG34e	ca. 580 / 23	ca. 640 / 25	ca. 380 / 15	—
HG44e	ca. 710 / 28	ca. 685 / 27	ca. 380 / 15	ca. 368 / 14
HG56e	—	ca. 710 / 28	ca. 380 / 15	—
HG66e	ca. 820 / 32	ca. 800 / 31	ca. 380 / 15	—

Ansicht X: Anschlussmöglichkeit für Ölspiegelregulator
View X: Possibility of connection of oil level regulator



- Dreilochanschluss für TRAXOIL (3xM6x10)
Three-hole connection for TRAXOIL (3xM6x10)
- Dreilochanschluss für ESK, AC+R, CARLY (3xM6x10)
Three-hole connection for ESK, AC+R, CARLY (3xM6x10)

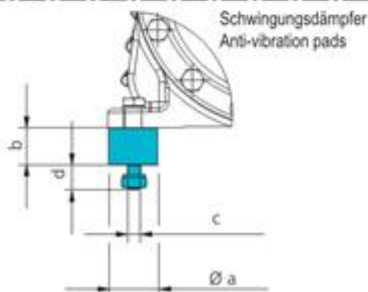

Typ / Type	Øa mm / inch	b mm / inch	c mm / inch	d mm / inch
HG12P	30 / 1.2	30 / 1.2	M8	20 / 0.8
HG22e	40 / 1.6	30 / 1.2	M10	20 / 0.8
HG34e	40 / 1.6	30 / 1.2	M10	20 / 0.8
HG44e	50 / 2.0	30 / 1.2	M12	25 / 1.0
HG56e	50 / 2.0	30 / 1.2	M12	25 / 1.0
HG66e	50 / 2.0	30 / 1.2	M12	25 / 1.0
HG88e	70 / 2.8	45 / 1.8	M12	37 / 1.5

ange without notice

HGX66e/1540-4 S

Engine: 380-420V Y/YY -3- 50Hz PW

Refrigerant: R404A, R507

Subject:

SV	Suction line valve, tube \varnothing ¹⁾	54 mm - 2 1/8 "
DV	Discharge line valve, tube \varnothing ¹⁾	42 mm - 1 5/8 "
A	Connection suction side, not lockable	1/8 " NPTF
A1	Connection suction side, lockable	7/16 " UNF
B	Connection discharge side, not lockable	1/8 " NPTF
B1	Connection discharge side, lockable	7/16 " UNF
C	Connection oil pressure safety switch OIL	1/8 " NPTF
D	Connection oil pressure safety switch LP	7/16 " UNF
D1	Connection oil return from oil separator	1/4 " NPTF
F	Oil drain	M 12 x 1.5
H	Oil charge plug	1/4 " NPTF
J	Connection oil sump heater	3/8 " NPTF
K	Sight glass	3 x M 6
L	Connection thermal protection thermostat	1/8 " NPTF
M	Oil strainer	M 12 x 1.5
O	Connection oil level regulator	3 x M 6
ÖV	Connection oil service valve	1/4 " NPTF
P	Connection oil differential pressure sensor	M 20 x 1.5
Q	Connection oil temperature sensor	1/8" NPTF
W	Connection for refrigerant injection	2 x 1/8" NPTF

1) Brazing connection

Subject to change without notice

To: venolia.stoffels@metraclark.co.za

From:

02.08.2022
Page 10 of 11

VAP 11.12.0

HGX66e/1540-4 S

Engine: 380-420V Y/YY -3- 50Hz PW

Refrigerant: R404A, R507

Subject:

BOCK colour the world
of tomorrow

Product photo



Subject to change without notice

To: venolia.stoffels@metraclark.co.za

From:

02.08.2022
Page 11 of 11

VAP 11.12.0